

# MIRANDA

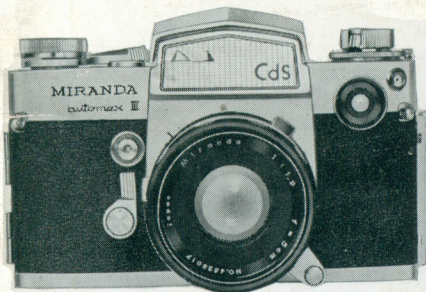

**automex III**

**MIRANDA CAMERA CO., LTD.**

*Tokyo Japan*

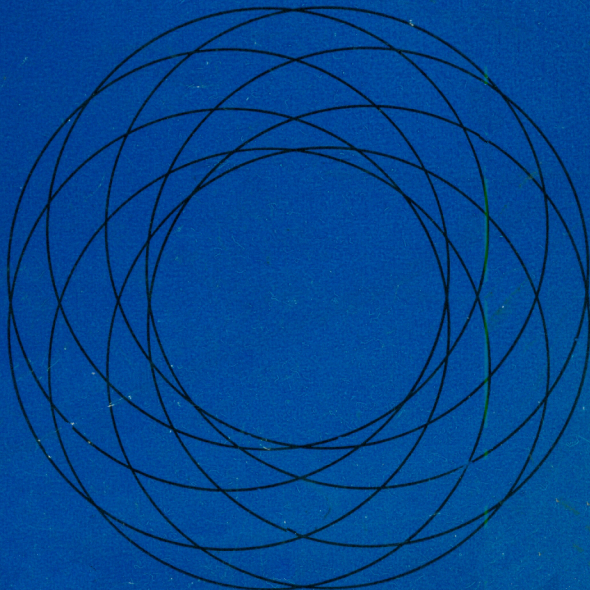



## CONTENTS

A Few Words About Your Miranda .....	2
Features of Your Miranda Automex III .....	4
Principal Parts .....	8
Film Loading and Unloading .....	10
Setting the Shutter Speed .....	14
Exposure .....	15
Viewing and Focusing.....	20
How to Use the Self-Timer .....	23
Taking Flash Pictures .....	24
Changing Lenses .....	26
Types of Lenses.....	28
Using Accessories with the Miranda Automex III ...	32
Care of Your Camera.....	44

*In order that you may derive the maximum enjoyment from this fine instrument, may we earnestly suggest careful reading of this manual before taking your first roll of film.*

## **A FEW WORDS ABOUT YOUR MIRANDA**

In cameras with coupled rangefinders, the lens and the rangefinder are operated simultaneously but are optically entirely separate entities, while the viewfinder is another separate entity. The rangefinder is mechanically complex with many moving parts which rarely stay in perfect adjustment in relation to the lens. Accordingly, the photographer who uses such a rangefinder frequently finds his pictures not as sharp as he had hoped. The viewfinder, on the other hand, usually contains no moving parts to get out of adjustment, but it is optically so imperfect that the photographer cannot tell with reasonable assurance what will be included, and what will be excluded, from his picture. In ordinary snapshooting the inconvenience may not be great. Today, however, photographers are becoming increasingly demanding.

More and more photographers are demanding that their cameras give them black and white negatives good enough to make very large prints and color transparencies good enough to project on to a large screen. Interest in fine pictures, artistically composed, is increasing and many photographers are demanding 35mm cameras which will enable them to compose and take pictures which formerly would require the use of large ground-glass-back cameras. Increasing numbers of photographers have discovered that small subjects—a single flower taken closeup—often make beautiful pictures. Technical, medical, and scientific workers are making photographs, frequently under extreme and exacting conditions.

These are the basic reasons why the single-lens reflex camera is today enjoying increasing popularity compared to the coupled rangefinder type.

In the first place, the Miranda single-lens reflex camera offers the advantages of ground-glass focusing. This is the most exacting system, the only one which uses the lens itself, has no moving parts other than the lens, and never gets out of adjustment. It works equally well at all distances from infinity to extreme close up, with all lenses from telephoto to wide angle and even when taking pictures through a microscope. In addition a beam-splitter (which has no moving parts) is built into the center of the ground glass. It offers an alternative method of focusing, by lining up the two halves of a split image or a micro split raster.

The ground glass on which the focus is adjusted is also the viewfinder. As a viewfinder, it is far superior to the type used on coupled rangefinder cameras, since it gives you the exact area of your picture, works equally well with all lenses at all distances, and when using a microscope. This is not surprising when you consider that the view that you see on your ground glass is the same view which the lens sees. It is merely being reflected up to your eye by a mirror. When you take a picture the mirror flicks out of the way, letting the same light rays go straight on back to the film. The result is a picture corresponding exactly to the scene which you saw in the viewfinder. In most cases the final picture will be even sharper than the scene as viewed. The automatic diaphragm makes this possible. The camera is focused with the lens wide open, when the depth of field is at its minimum, but the picture is taken with the diaphragm shut down, with increased depth of field and sharpness.

WE HOPE THAT YOUR MIRANDA WILL BE A GOOD COMPANION TO YOU FOR A LONG TIME TO COME, THAT YOU WILL ENJOY USING IT, AND THAT THE PICTURES YOU TAKE WITH IT WILL GIVE YOU MUCH PLEASURE AND SATISFACTION.

# FEATURES

OF

YOUR

MIRANDA

AUTOMEX III

## 1. **Correct Exposure—Easy and Fast:**

The needle of the built-in Cds exposure meter is inside the viewfinder, together with another needle which is geared to the shutter and diaphragm mechanism. To set the exposure, it is merely necessary to look through the viewfinder and adjust the diaphragm lever until the two needles are superimposed. Your camera is then set for correct exposure for the scene which you are viewing. This feature works with any of the AUTO-MIRANDA AUTOMEX lenses.

## 2. **The Fully Automatic Diaphragm:**

The diaphragm of all AUTO-MIRANDA AUTOMEX lenses are fully automatic. This means the diaphragm stays wide open except at the instant a picture is taken. This assures a bright image in the viewfinder and easy focusing. When the shutter release button is pressed to take a picture, the diaphragm closes down instantly to the pre-selected aperture and then automatically reopens to full aperture. A control lever is provided, however, which enables you to close the diaphragm manually when desired so that you can see the depth of field at "taking" aperture.

### **3. Single Large Shutter Speed Dial:**

Shutter speeds are set on a large, easily read, easily adjusted dial which can be turned without being lifted. It is a shutter speed-control you can set even with gloves on. Speeds can be set either before or after the shutter is cocked, the dial does not rotate when the shutter is released. Shutter speeds range from 1 second to 1/1000 second, plus B. An uncluttered top deck and automatic controls make picture taking much surer and faster.

### **4. Eye-Level Viewfinder:**

The pentaprism viewfinder offers a view-finding image which is brilliant, evenly illuminated, full life size, has no parallax, is precisely defined at the edges, is grainless, can be seen with glasses on, and is not reversed from right to left—as it is in the case of all twin lens reflex cameras and some single lens reflexes. A fresnel lens incorporated into the viewing system is responsible for brightening the image out to the edges. A multisplit-image type rangefinder is built into the center of the ground glass giving a choice of focusing methods, either by the ground glass, or with the rangefinder.

### **5. AUTO-MIRANDA Lenses:**

These lenses utilize a new design made possible by recently improved, rare earth glass with remarkable properties. They make pictures of extraordinary sharpness and brilliance. The lenses are quickly removed permitting the use of other lenses with a wide range of focal lengths. Instead of interchanging merely the front element of a lens, the MIRANDA AUTOMEX offers the much superior sharpness and quality of a complete line of true wide angle and telephoto lenses.

## **6. Lens Mount:**

Compared with other 35mm single lens reflex cameras, the flange to focal plane distance is shorter and the lens mount opening is larger. This makes it possible with adapters to use lenses made for other cameras. These lenses will focus normally at any distance. The large lens mount opening makes possible the use of improved high speed lenses without restrictions imposed by the size of the mount. It eliminates vignetting when the lens is extended for taking close-ups, and when a fast lens of long focal length is used.

## **7. Close-Up Photography:**

The standard 50mm lenses can be focused as close as 17 inches without attachments. Pictures as close as 10 inches can be made by simply inserting an extension adapter between the lens and the camera. Still closer pictures can be made easily by further extending the lens using extension tubes or the Focabell. Close-up photos made by extending the MIRANDA standard or telephoto lens out from the camera are sharper than pictures taken with add-on lenses. In addition, ultra close-ups can be taken, which is not possible with add-on lenses. Pictures can also be taken through a microscope by using an adapter available to fit on all types of microscopes.

## **8. Instant-Return Mirror:**

One of the advanced features of the MIRANDA AUTOMEX is the instant return mirror. When the shutter release button is pressed, the mirror swings up permitting the light rays from the lens to reach the film as the focal plane shutter opens. Immediately after the film is exposed the mirror returns to the viewing position. When the mirror is up, the view through the viewfinder is momentarily blacked out, but, at speeds of 1/15 second and faster, the mirror returns to the viewing position so quickly that the photographer hardly notices the interruption. This is an important aid in following fast action, and when fleeting expressions are important to the success of the picture.

Unlike many other cameras with instant return mirrors, the MIRANDA's viewfinder image returns as bright as before taking the picture. This is because the diaphragm is fully automatic; it instantly and automatically reopens fully after a picture is taken.

#### **9. Quick Consecutive Picture Taking:**

The AUTOMEX has many features which make picture taking quicker and easier. The rapid film winding lever has a short light stroke. It advances the film, cocks the shutter, and registers the exposure on the exposure counter dial. You can tell at a glance whether or not the shutter is cocked since the shutter speed index is half white when the shutter is not cocked, all red when it is cocked.

Exposed film is quickly rewound into the cartridge by the rapid rewind crank. To rewind the film, you press the rewind button once (you do not have to hold it down).

The exposure counter on the MIRANDA AUTOMEX automatically goes to the starting position "S" when the camera back is opened in preparation for loading a new roll. You do not have to set the counter manually every time you load the camera.

#### **10. Self-Timer:**

The self-timer provides a variable delay of 10 seconds, making it easy for the photographer to get into the picture. Since the self-timer releases the shutter without the slightest jar, it can be used conveniently instead of a cable release for critical macro and micro photography. The MIRANDA self-timer is believed to be the finest on any camera.

#### **11. Quiet, Vibration-Free Operation:**

Vibration-free operation is result of the precision quality and superior design of the MIRANDA AUTOMEX shutter and mirror mechanism. Operation is so smooth you are assured your pictures will not lose their razor sharp definition due to internal vibration.

# PRINCIPAL

## PARTS

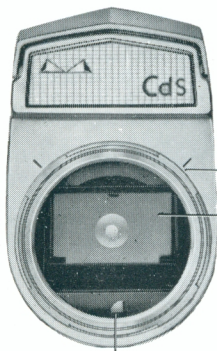

Screw Thread Mount

- Bayonet Mount Flange
- Instant Return Mirror

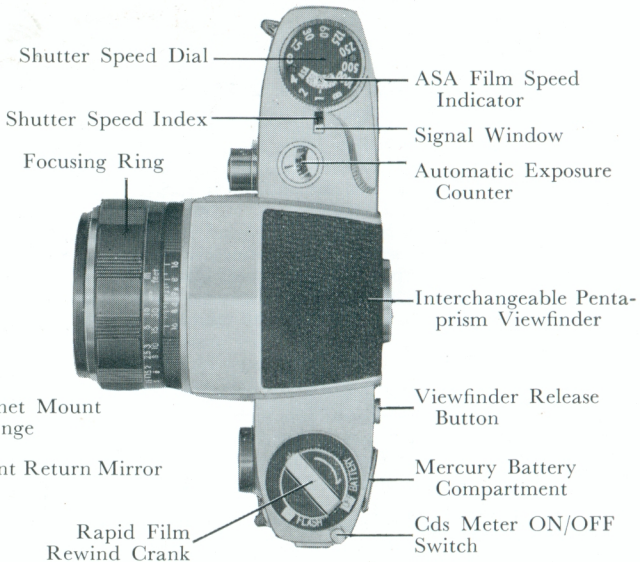

Rapid Film Rewind Crank

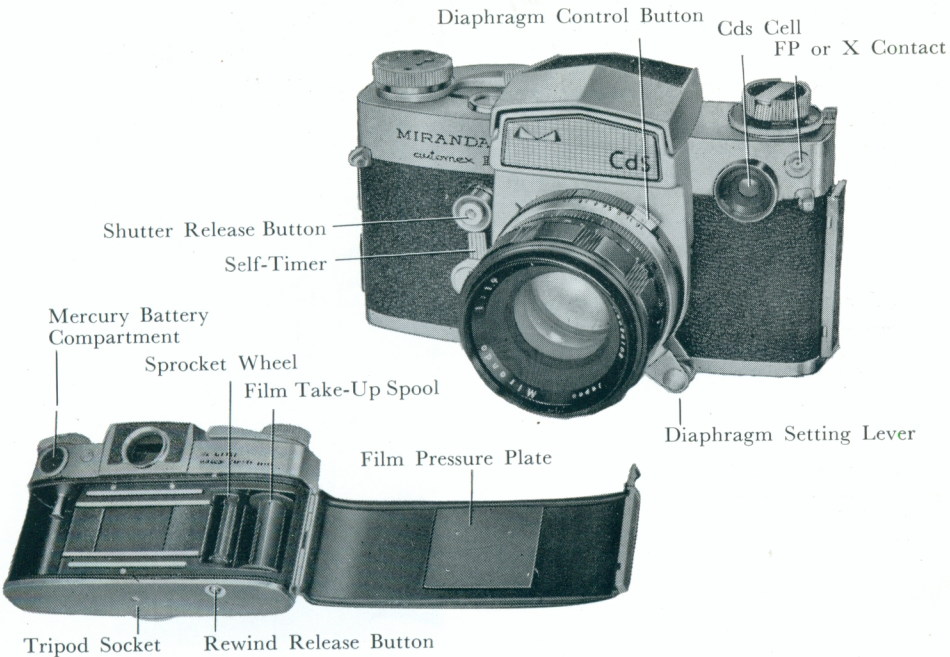

## FILM

## LOADING

## AND

## UNLOADING

*It is always advisable to load and unload the film in the shade, rather than in direct sunlight, to prevent fogging the film. Keep the film cartridge in its container until it is ready for use and then return it to the container immediately after removing it from the camera.*

### How to Unlock the Back Cover:

Pull up on the sliding lock at the end of the camera and the hinged back cover will open.

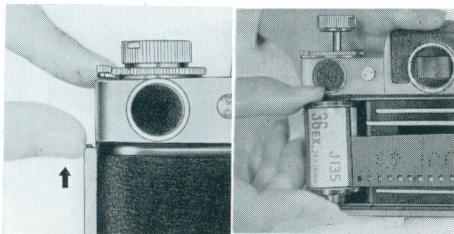

### How to Put Film in the Camera:

Pull the rewind knob up, place the film cartridge in the film chamber, and push the rewind knob back down to hold the cartridge in place. If the knob does not go all the way down, turn it a little and it will seat.

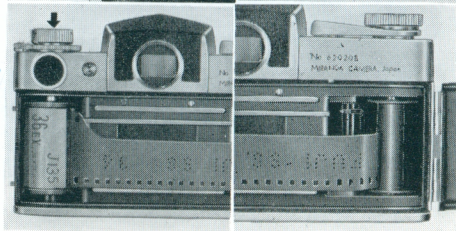

If necessary, turn the take-up spool (the flange is serrated for this purpose) until the slot is on top. It may be turned in either direction for this purpose. Then gently draw the film leader farther out of the cartridge and insert it into the slot. Turn the take-up spool toward the center of the camera, for 1/2 revolution or more.

Hold the lip of the cartridge (where the film comes out) down against the camera and turn the rewind knob on top of the camera in the direction of the arrow. Continue turning until there is resistance and all of the slack in the cartridge has been taken up. You will notice that a 20-exposure cartridge will require several turns to absorb all of the slack while a 36-exposure cartridge will have very little slack. Be sure the perforations in the film have caught in the teeth of the sprocket wheel. If not, turn the take-up spool until they catch. Close the back cover and push the sliding back lock down.

Release the shutter, and advance the film with a full stroke of the film winding lever, while watching the rewind knob to see that it turns, then release the shutter a second time.

If the rewind knob turns, it shows that the film is moving properly through the camera. If it does not turn, either the slack was not fully taken up in the cartridge or the film is not properly attached to the take-up spool.

After one more stroke, release the shutter, and the exposure counter will automatically register "1", and indicate that the camera is now ready for the first shot. The exposure counter will, thereafter, automatically register the number of exposures taken.



## How to Set the ASA Speed Indicator:

As soon as you have loaded the camera, be sure to adjust the ASA speed indicator (ASA 25-1600) on the shutter speed dial to the ASA speed of the film you have loaded. Lift the shutter speed dial and rotate it until the ASA speed is opposite the indicator mark. Setting the ASA speed is essential to exposure determination since the ASA speed indicator is cross coupled to the indicator needle in the viewfinder, along with the diaphragm and the shutter. If the ASA speed is not correctly set, the built-in Cds exposure meter will not indicate correct exposure settings.

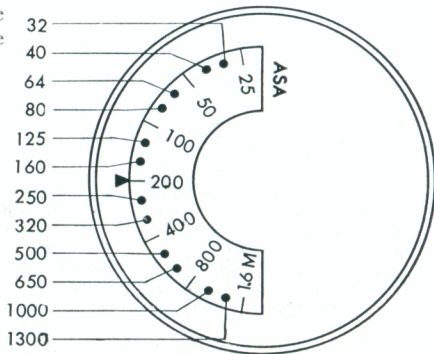
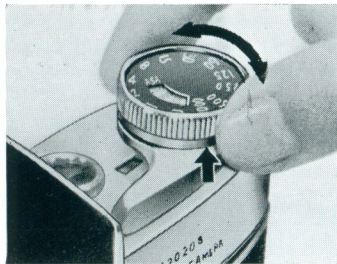

*After the full roll of film has been exposed, the film winding lever can not be pushed. Do not try to force it, but rewind the film back into the cartridge and remove the film from the camera.*



### Unloading Film

1. Depress the film rewind button located at the bottom of the camera. (It is unnecessary to press the button continuously while rewinding the film.)
2. Flip up the rewind crank on the rewind knob and wind in the direction of the arrow. At the end of the roll you will feel the resistance increase and then suddenly cease. Turn the rewind crank several more times to make certain the film has been entirely rewound.
3. Open the back cover, pull up the rewind knob and remove the film cartridge. Put the cartridge back into its container. This roll is now ready for development.

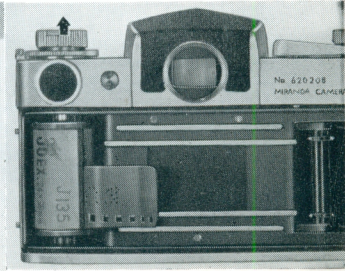
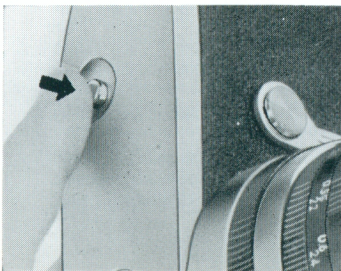

**SETTING  
THE  
SHUTTER  
SPEED**

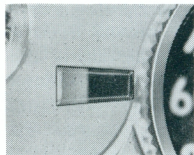
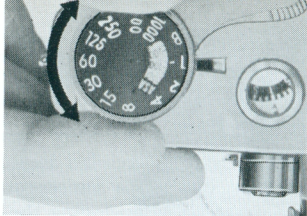

Shutter is not  
cocked (White)

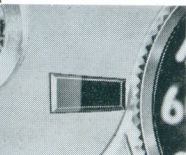
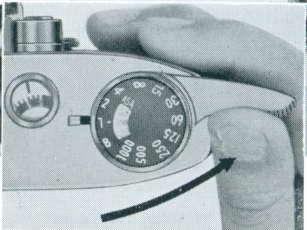

Shutter is cocked  
(Red)

The shutter speed is very easily set by rotating the shutter speed dial. Just rotate, do not lift the dial. The setting can be made either before or after cocking the shutter. The desired speed should be set opposite the shutter speed index. This index will also tell whether or not the shutter is cocked. The index is half red and half white when the shutter is not cocked. It is all red when the shutter is cocked.

The speed of 1/60 second is indicated in red on the dial. This is the speed which is used when taking electronic flash pictures.

Time exposures are taken by setting "B" opposite the index. In this case a cable release should be used and the shutter will remain open for as long as the cable release is pressed. If extremely long exposures are to be made, a locking type cable release is suggested.

## EXPOSURE

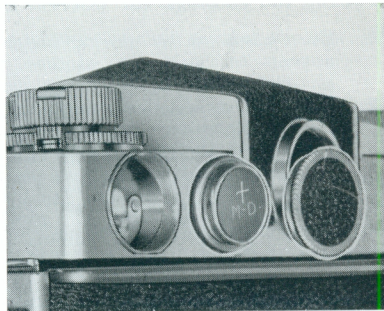

The Exposure in your Miranda Automex III is controlled by a highly sensitive Cadmium sulfide Exposure meter.

The meter is directly coupled to ASA speed dial as well as shutter speed and diaphragm control so that correct exposure may be automatically obtained.

Once the ASA speed of the film is set at the time of loading only either the shutter speed dial or the diaphragm setting lever need be adjusted to obtain the correct exposure.

The Automex III exposure meter is powered by a small mercury cell located in a compartment behind the rewind knob. Before using the camera for the first time, unscrew the battery compartment cover and insert supplied cell making certain that the plus side is facing out then replace cover.

The normal life of the mercury battery is 1½-2 years provided the meter is switched off when not in use. Replace battery only with Mallory, National MD, RM 625R, PX 13 or similar type.

## Setting the Camera for Correct Exposure

1. Turn meter on by moving switch under Rewind knob forward until the sign "ON" appears in the battery window. To insure long battery life, turn meter off after completing picture sequence.
2. Point the camera towards the subject, look through the viewfinder, and you will see the exposuremeter pointer on the right. The pointer will move according to the light intensity of the subject area.
3. The other needle which you see in the viewfinder has a ☺ on the end. It is an exposure setting indicator. Turn either the shutter speed dial or the diaphragm setting lever and this indicator will move. By superimposing this indicator over the exposure meter pointer, you will automatically set the camera for correct exposure.
4. Although you may control exposure by turning either the shutter speed dial or the diaphragm setting lever, it is normally advisable to pre-select the shutter speed. Then, when preparing to take a picture, you look through the viewfinder and merely adjust the diaphragm setting lever until the two needles are superimposed.
5. Exposure settings can, of course, be made disregarding the built-in meter. This will be the case when taking flash pictures, for example. In such cases, the built-in meter can be simply ignored and the desired shutter speed set on the shutter speed dial, and the desired diaphragm opening set with the diaphragm setting lever. With the MIRANDA there is nothing to disconnect or get in your way. The built-in meter and cross coupling system is there to be used as desired, but can be simply disregarded if preferred.

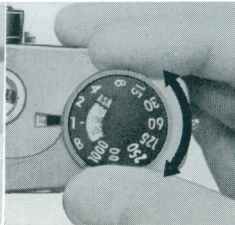
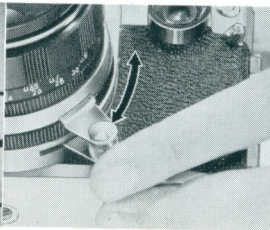

## Suggested Shutter Settings

The following suggested shutter settings apply to pictures taken in normal daylight with a hand-held camera :

With slow color films, preselect :	1/125
With high speed color and black and white films, preselect :	1/250
With ultra high speed black and white film, preselect :	1/500

These suggested settings should be varied according to preference and circumstances. If the light is dull, or if the camera is being used on a tripod, slower shutter speeds may well be used. If the light is very dull, and you cannot superimpose the needles by adjusting the diaphragm alone, then the shutter speed should be changed until the needles are superimposed. If the shutter speed is reduced to 1/15 or slower, a tripod should be employed. Otherwise camera movement is very likely to result in an unsharp picture.

If unusual depth of field is necessary for a particular picture, a different procedure may be used. In this case you may preselect a small diaphragm opening. (f:16 is the smallest in the case of the standard lens) and then set the correct exposure by adjusting the shutter speed dial.

## Hints on Using the Exposure Meter

The window of the Miranda Automex III Cds meter is located on the right side of the camera. This position minimizes the possibility of accidentally covering the window with a finger or hand causing incorrect exposure.

The angular coverage of the meter is 40° or approximately the diagonal of the film plane when using a normal 50mm lens, so that only the light actually reflected from the picture area is calculated.

Caution: Avoid unnecessarily long exposure to excessively bright light, as this may affect the cell's responsiveness for a brief period of time.

## PORTRAITS

The exposure meter measures the light reflected by the entire scene. If a portrait is being taken very close up, the reading may be controlled by the light reflected from the subject's face only. However, if the picture is taken at a little distance, the meter will be influenced by the background more than by the flesh tones. This raises no problem where the background is of average brightness. But if the background is very dark, for example foliage in the shade, or if it is very light, for example the sky, then to obtain correct exposure for the flesh tone, the exposure should be set either up close to the subject, or with the camera pointed toward some area which is about the same brightness as the subject. The palm of the photographer's hand, held 3 or 4 inches in front of the meter window, can be used to good advantage.





## LANDSCAPE

When shooting a landscape, it is advisable to point the camera down slightly when setting the exposure so that the exposure will be correct for the land rather than being inflated by the sky which may be brighter than the land.

# **VIEWING AND FOCUSING**

The MIRANDA AUTOMEX offers two methods of focusing: (1) The center of the ground glass is equipped with a multi split range finder. This optical grating distorts the image unless it is in perfect focus. By simply focusing the lens until the center image is completely undistorted, critical focus can be obtained. (2) The camera can also be focused by focusing lens until image is at maximum sharpness on the surrounding ground glass. The Miranda also offers a wide variety of focusing screens for special purposes (ask your camera dealer about them)

## **DEPTH OF FIELD:**

This is the range that is in sharp focus for any particular distance and diaphragm setting. There is relatively very little depth of field where close-up subjects are focused on, and a great deal of depth of field in the case of more distant subjects. Closing the diaphragm down increases the depth of field, and opening the diaphragm up reduces the depth of field. The depth of field also varies with the lens used. Wide angle lenses have lots of depth of field while with telephoto lenses the depth of field is much reduced. If your picture is such that you want both nearby and distant objects to be in sharp focus, then the smallest possible diaphragm should be used. However, very frequently the composition of a picture can be improved by having the principal subject in sharp focus while other objects in the scene are soft and out of focus. This will deemphasize distracting background or foreground objects, and concentrate the viewer's attention on the principal subject.

Should you want to preview the depth of field of a scene before shooting, you can readily do so by depressing the depth of field control lever on top of the lens barrel. When pressure is released diaphragm immediately reopens.

# Depth-of-Field Table for the MIRANDA AUTOMEX

with Auto-Miranda f:1.9 50 mm

Distance	Aperture f / 1.9	Aperture f / 2.8	Aperture f / 4	Aperture f / 5.6	Aperture f / 8	Aperture f / 11	Aperture f / 16
∞	135'6"	91'9 <sup>3</sup> / <sub>5</sub> "	64'0"	45'9 <sup>3</sup> / <sub>5</sub> "	32'3 <sup>3</sup> / <sub>5</sub> "	23'7 <sup>1</sup> / <sub>5</sub> "	16'3 <sup>3</sup> / <sub>5</sub> "
	~ ∞	∞ ~	~ ∞	~ ∞	~ ∞	~ ∞	~ ∞
feet	24'9 <sup>3</sup> / <sub>5</sub> "	22'9 <sup>3</sup> / <sub>5</sub> "	20'8 <sup>2</sup> / <sub>5</sub> "	18'3 <sup>3</sup> / <sub>5</sub> "	15'9 <sup>3</sup> / <sub>5</sub> "	13'4 <sup>4</sup> / <sub>5</sub> "	10'8 <sup>2</sup> / <sub>5</sub> "
30	~38'8 <sup>2</sup> / <sub>5</sub> "	~44'8 <sup>2</sup> / <sub>5</sub> "	~56'3 <sup>3</sup> / <sub>5</sub> "	~86'6"	~ ∞	~ ∞	~ ∞
	13'7 <sup>1</sup> / <sub>5</sub> "	13'0"	12'3 <sup>3</sup> / <sub>5</sub> "	11'6"	10'4 <sup>4</sup> / <sub>5</sub> "	9'3 <sup>3</sup> / <sub>5</sub> "	8'0"
15	~16'10 <sup>4</sup> / <sub>5</sub> "	~17'10 <sup>4</sup> / <sub>5</sub> "	~19'6"	~22'1 <sup>1</sup> / <sub>5</sub> "	~27'9 <sup>3</sup> / <sub>5</sub> "	~40'9 <sup>3</sup> / <sub>5</sub> "	~195'7 <sup>1</sup> / <sub>5</sub> "
	7'7 <sup>1</sup> / <sub>5</sub> "	7'4 <sup>4</sup> / <sub>5</sub> "	7'2 <sup>2</sup> / <sub>5</sub> "	6'11 <sup>1</sup> / <sub>3</sub> "	6'6"	6'1 <sup>3</sup> / <sub>5</sub> "	5'6"
8	~8'6"	~8'9 <sup>3</sup> / <sub>5</sub> "	~9'1 <sup>1</sup> / <sub>5</sub> "	~9'7"	~10'6"	~11'9"	~15'3 <sup>3</sup> / <sub>5</sub> "
	4'10 <sup>4</sup> / <sub>5</sub> "	4'9 <sup>3</sup> / <sub>5</sub> "	4'8 <sup>2</sup> / <sub>5</sub> "	4'7 <sup>1</sup> / <sub>5</sub> "	4'4 <sup>4</sup> / <sub>5</sub> "	4'2 <sup>2</sup> / <sub>5</sub> "	4'0"
5	~4'2 <sup>2</sup> / <sub>5</sub> "	~5'3 <sup>3</sup> / <sub>5</sub> "	~5'4 <sup>4</sup> / <sub>5</sub> "	~5'7 <sup>1</sup> / <sub>5</sub> "	~5'9 <sup>3</sup> / <sub>5</sub> "	~6'2 <sup>2</sup> / <sub>5</sub> "	~7'0"
	3'0"	3'0"	2'6"	2'4 <sup>4</sup> / <sub>5</sub> "	2'4 <sup>4</sup> / <sub>5</sub> "	2'3 <sup>3</sup> / <sub>5</sub> "	2'3 <sup>3</sup> / <sub>5</sub> "
3	~3'1 <sup>1</sup> / <sub>5</sub> "	~3'1 <sup>1</sup> / <sub>5</sub> "	~3'2 <sup>2</sup> / <sub>5</sub> "	~3'2 <sup>2</sup> / <sub>5</sub> "	~3'3 <sup>3</sup> / <sub>5</sub> "	~3'4 <sup>4</sup> / <sub>5</sub> "	~3'7 <sup>1</sup> / <sub>5</sub> "
inch	2'5 <sup>3</sup> / <sub>5</sub> "	2'4 <sup>2</sup> / <sub>5</sub> "	2'5 <sup>1</sup> / <sub>5</sub> "	2'4 <sup>4</sup> / <sub>5</sub> "	2'4 <sup>2</sup> / <sub>5</sub> "	2'3 <sup>4</sup> / <sub>5</sub> "	2'2 <sup>4</sup> / <sub>5</sub> "
30	~2'6 <sup>3</sup> / <sub>5</sub> "	~2'6 <sup>3</sup> / <sub>5</sub> "	~2'7 <sup>1</sup> / <sub>5</sub> "	~2'7 <sup>3</sup> / <sub>5</sub> "	~2'8 <sup>1</sup> / <sub>5</sub> "	~2'9"	~2'10 <sup>2</sup> / <sub>5</sub> "
	1'7 <sup>4</sup> / <sub>5</sub> "	1'7 <sup>4</sup> / <sub>5</sub> "	1'7 <sup>3</sup> / <sub>5</sub> "	1'7 <sup>3</sup> / <sub>5</sub> "	1'7 <sup>2</sup> / <sub>5</sub> "	1'7 <sup>1</sup> / <sub>5</sub> "	1'6 <sup>4</sup> / <sub>5</sub> "
20	~1'8 <sup>3</sup> / <sub>5</sub> "	~1'8 <sup>3</sup> / <sub>5</sub> "	~1'8 <sup>3</sup> / <sub>5</sub> "	~1'8 <sup>4</sup> / <sub>5</sub> "	~1'9 <sup>1</sup> / <sub>5</sub> "	~1'9 <sup>2</sup> / <sub>5</sub> "	~1'9 <sup>4</sup> / <sub>5</sub> "
	1'4 <sup>4</sup> / <sub>5</sub> "	1'4 <sup>4</sup> / <sub>5</sub> "	1'8 <sup>4</sup> / <sub>5</sub> "	1'4 <sup>3</sup> / <sub>5</sub> "	1'4 <sup>3</sup> / <sub>5</sub> "	1'4 <sup>2</sup> / <sub>5</sub> "	1'4 <sup>1</sup> / <sub>5</sub> "
17	~1'5"	~1'5"	~1'5 <sup>1</sup> / <sub>5</sub> "	~1'5 <sup>2</sup> / <sub>5</sub> "	~1'5 <sup>2</sup> / <sub>5</sub> "	~1'5 <sup>3</sup> / <sub>5</sub> "	~1'5 <sup>4</sup> / <sub>5</sub> "

## HOLD CAMERA FIRMLY



When taking a picture it is very important not to move the camera when you press the shutter release button. You should learn to release the shutter very smoothly in the same way that an expert target shooter very gently squeezes the trigger of his rifle. It is a good idea to practice releasing the shutter, with no film in the camera. It will help to grasp the camera rather firmly with the left hand, and press it firmly against the face, but to hold the camera lightly and press the shutter release button very lightly with the right hand. Many people also find that it helps to hold the camera steady by keeping the arms fairly close to the body at the elbows.

To use the self-timer, move the self-timer lever located on the front of the camera body 90° to the left. It allows you a time delay of approximately 10 seconds after pressing the shutter release button. You may also get any intermediate time delay under 10 seconds depending on the angle to which you depress the lever. You may set the self-timer either before or after the shutter is set.

## HOW TO USE THE SELF-TIMER

After setting the self-timer, if you decide not to use it, you simply have to return the lever to its original position, and the self-timer will be disconnected. The self-timer may be used very conveniently in place of a cable release. It will release the shutter without any vibration.

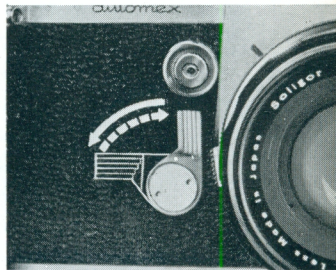

## TAKING FLASH PICTURES

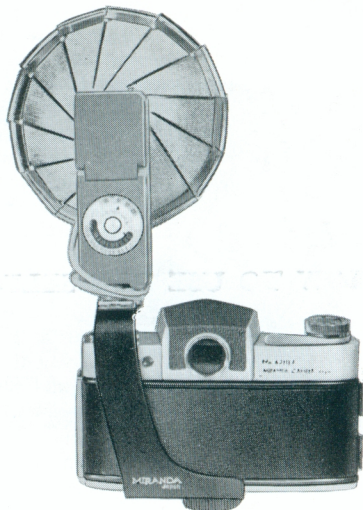

The MIRANDA has built-in flash synchronization. Flash bulbs can be inserted into a flash gun either before or after the shutter is cocked without risk of unintentional firing.

A special bracket is available providing a standard shoe to which any shoe-mounted flash unit can be attached. Other shoe-mounted accessories can also be mounted on this bracket.

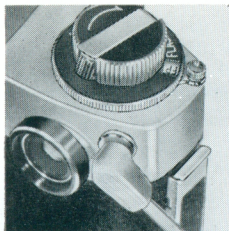

For taking pictures with ordinary flash bulbs, turn the selector dial to FP (focal plane).

For taking pictures with electronic flash, turn the selector dial to X. When electronic flash is used the shutter *must* be set at 1/60 marked in Red on speed dial.



The following table shows the types of flash bulbs (including electronic flash) which can be used, and the proper shutter speed dial setting and selector dial setting.

Type of Flash	Focal Plane Bulbs No. 6 and 6B No. 26 and 26B	No. 5 and 5B* No. 25 and 25B	AG—1° AG—1B.	Electronic Flash
Shutter Speed Dial Setting	1/30 to 1/1000	1/125	1/125	1/60
Selector Dial Setting	FP	FP	FP	X

\*With these bulbs, the light pattern will be less even than when focal plane bulbs or electronic flash are used.

## CHANGING LENSES

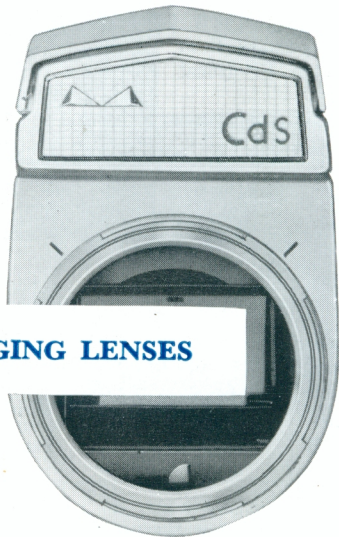

Press the button on the lens barrel just below the shutter release of the camera and you can remove the lens with only a  $1/8$ th counter-clockwise turn.

When attaching a lens, you must fit the diaphragm setting lever of the lens to the diaphragm setting lever of the camera and then press the lens on the camera lining up the red dot on the lens with the red line on the camera. A  $1/8$ th turn of the lens clockwise will secure it. A wide-angle and a telephoto lenses may be mounted in the same way. The inner diameter of the MIRANDA lens mount is larger than on any other 35mm camera. With the use of adapters, therefore, lenses of many other makes, including Exacta, Praktica, and Pentax Yashica lenses, may be used.

Line up the red dot on the lens barrel and the red line on the camera body.

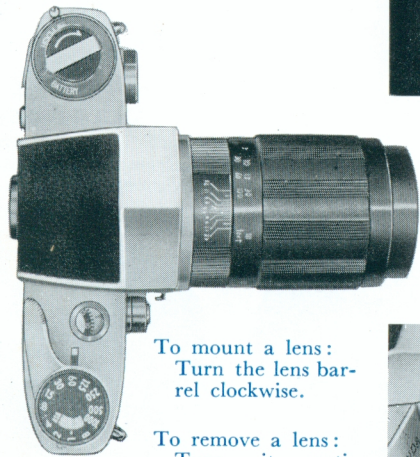
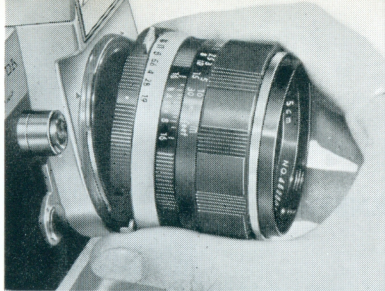

To mount a lens:  
Turn the lens barrel clockwise.

To remove a lens:  
Turn it anti-clockwise, while  
pressing the lens  
release button.

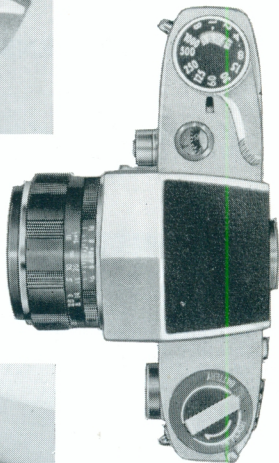
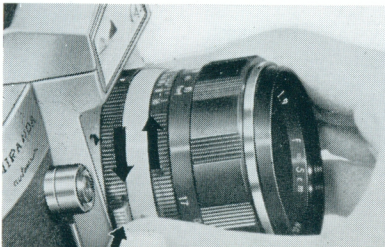

## TYPES OF LENSES

*Many different types of lenses can be used on the  
MIRANDA AUTOMEX.*



**AUTOMEX LENSES:**



Before exposure

The Same Brightness  
← Before & After →  
Exposure



These lenses feature a fully automatic diaphragm internally controlled and are coupled directly to the built-in exposure meter system. The diaphragm opening of these lenses is normally automatically set by the meter coupling system, discussed previously.



At the moment of  
exposure



Immediately after  
exposure





### **SOLIGOR-MIRANDA AUTOMATIC or AUTO-MIRANDA Lenses for Model F**

The automatic lenses containing fully automatic internal diaphragm control operate perfectly on the MIRANDA AUTOMEX, but they are not coupled to the meter system. The diaphragm opening of these lenses may be determined by the built-in meter system in the same fashion as described in the previous chapter on exposure with AUTOMEX lenses, except that after the meter needles have been superimposed the proper diaphragm opening must be read off the diaphragm scale on the side of the lens mount, and the lens set accordingly. When you depress the release button, the diaphragm will, of course, function automatically.

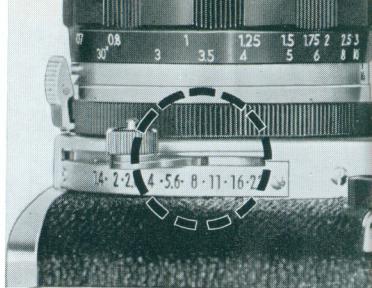

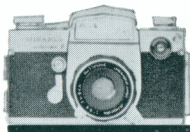

### **OTHER LENSES:**

SOLIGOR-MIRANDA lenses, and lenses of other makes that fit on the MIRANDA, by means of adapters, can also be used on the MIRANDA AUTOMEX.

After the exposure has been determined by the AUTOMEX meter, the correct setting can be read on the camera diaphragm scale. This setting should then be transferred to your lens. With preset lenses, care should be taken, of course, that the diaphragm is manually closed before the exposure is made.



The 50mm standard lens was used with an extension adapter and 32mm extension tube to take this picture.

**USING ACCESSORIES**  
**WITH**  
**THE**  
**MIRANDA AUTOMEX**

Close-up with 50mm lens mounted on an extension adapter & 8mm tube.



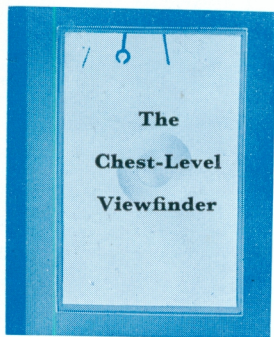

A chest-level collapsible viewfinder (VF 1) and a critical focuser (VF 3) are available as accessories and may be substituted for the standard viewfinder when so desired.

The VF 1 viewfinder opens and closes with a touch. A hinged magnifier is quickly raised for accurate focusing.

The critical focuser (VF 3) is of unique design and efficiency. It has two positions, one giving a five-times magnification of the entire field of view, the other giving a fifteen-times magnification of the central portion of the field. The fifteen-times magnification is for ultracritical focusing.

A chest-level viewfinder will be found convenient wherever it is desired to look into the top of the camera, rather than the back, for viewing and focusing. This may frequently be the case when taking pictures of very small subjects, for example in nature photography. With this kind of viewfinder, the image is reversed from right to left.

To remove the viewfinder on the camera, pull the viewfinder release to the left and at the same time gently draw the viewfinder to the rear. To replace with the other viewfinder, insert the finder's rail into the groove of the camera and push gently forward, it will automatically lock into place.

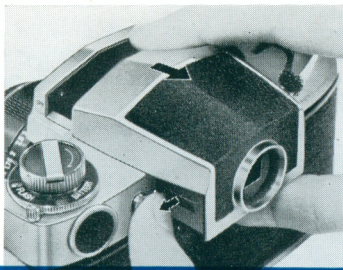

VF 1 Viewfinder



VF 3 Viewfinder  
(magnification  $\times 15$ )

VF 3 Viewfinder  
(magnification  $\times 5$ )

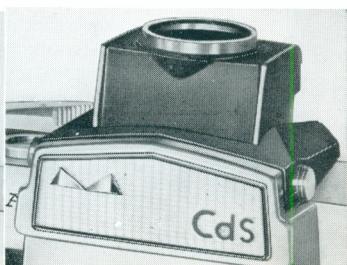
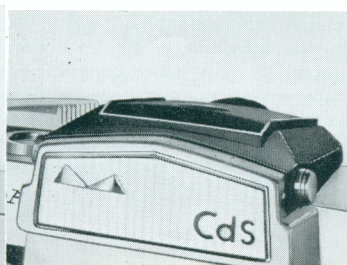
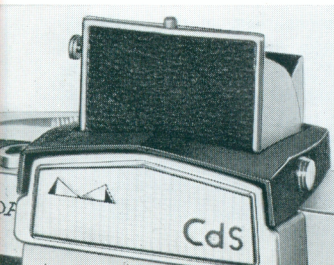



**Extension  
Adapter  
and  
Extension  
Tubes**

The 50mm standard lens will focus to a distance as close as 17 inches without an accessory. By adding an extension adapter between the camera and the lens, pictures can be taken from 17 inches to 10 inches. To take pictures at still closer distances, extension tubes are added between the extension adapter and the camera. The tubes are supplied in lengths of 8, 16 and 32mm and enable the photographer to take full-frame pictures of subjects the size of postage stamps and even smaller.

In addition to the regular extension tubes, a special helical focusing tube is available. This tube is used between the camera and the lens either alone, or in combination with one or more regular extension tubes. The purpose of the focusing tube is to make focusing in close-up photography more flexible than it is when using only the focusing range which is afforded by the lens. The focusing tube is 16mm long when fully telescoped and 24mm long when fully extended.

When extension tubes are used, the automatic diaphragm mechanism of the lenses will not be operative. Accordingly, you will have to set the diaphragm manually. (The method of doing this is described on page 29). The exposure meter will not be coupled with the diaphragm either. However, the exposure setting can be determined by using the built-in meter in the usual way. The correct diaphragm opening, to be used with whatever shutter speed is set, can be read off the front of the camera alongside the diaphragm setting lever. This setting must be transferred to the lens manually using the diaphragm setting lever on the lens.

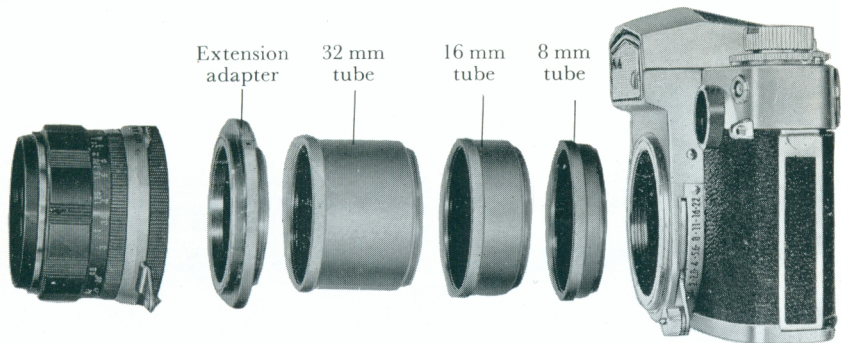
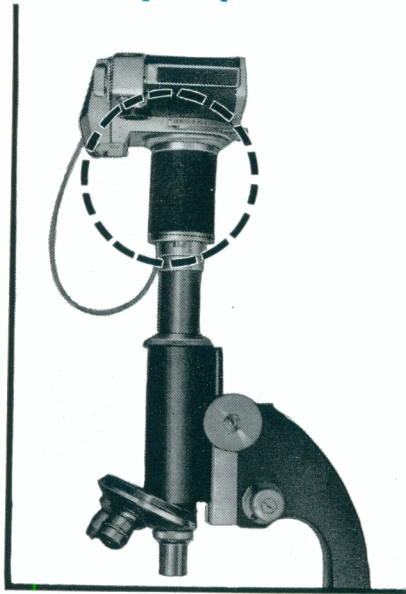

Table for Use with Extension Adapter and tubes and 50mm Standard Lens

Extension Adapt. and Tubes (length of tubes in mm.)	Total length including Adapter (in mm.)	Field of View Covered (in mm.)	Size-Image on Film to Subject	Increase Needed in Exposure	Nearest to Farthest Point which can be Focused on (in mm.)
Adapter only	8	156 by 238	0.15	1.3	185.4 to 358.5
Adapter and 8	16	78 by 117	0.31	1.7	131.3 to 189.5
" 16	24	52 by 78	0.46	2.1	104.0 to 133.1
" 8+11	32	40 by 60	0.62	2.6	87.4 to 105.0
" 32	40	32 by 48	0.77	3.1	76.4 to 88.1
" 8+32	48	26 by 39	0.92	3.7	68.4 to 76.8
" 16+32	56	24 by 36	1.08	4.3	62.5 to 68.8
" 8+16+32	64	20 by 30	1.23	5.0	57.8 to 62.8

Note : 25.4 mm equal 1 inch

## The Microscope Adapter



Pictures may be taken through a microscope by removing the lens and inserting the microscope adapter between the MIRANDA and a microscope. In effect, the microscope becomes the camera's lens. The subject to be microphotographed can be viewed and focused using either the camera's regular eye-level viewfinder, or, if preferred, the accessory chest level viewfinder VF 1 or VF 3.

1. Take off the front piece of the microscope adapter.
2. Remove the eye-piece of the microscope.
3. Insert the eye-piece of the microscope into the front piece of this adapter and put these on the microscope, fastening them by means of the screw on the side.
4. Take the lens off the camera and screw the body of the adapter into the camera.
5. Connect the front piece to the body of the adapter.

Pictures may then be taken through the microscope.

## The Focabell

The Focabell is a bellows-type focusing device intended primarily for taking close-up pictures. It focuses over an extreme range very quickly and conveniently. There are two provisions for changing the focus, one for rapid shifts and one for critical adjustments. The Focabell is made with fine precision, is very rigid, and will be found to satisfy the most exacting requirements. In addition to MIRANDA lenses, lenses of other makes can be used with adapters. Telephoto lenses in short mounts can be focused from infinity: other lenses only for close-up photography.



### List of Other Accessories

Focabell Single track bellows extension

Double Release

Pistol Grip

MIRANDA Everready Case

Leather Cases for all MIRANDA Lenses

Flash Gun Bracket

Helical Focusing Extension Tube

Lens Adapters

X•M adapter with this adapter any lens made for the Exacta camera can be used from close-up to infinity

P•M adapter with this adapter any lens made for the Praktica or Pentacon camera may be used from close-up to infinity

L•F adapter with this adapter any lens with standard Leica threads can be used for close-up photography

CS•F adapter with this adapter any standard focal length Contax or Nikon lens can be used for close-up photography

CT•F adapter with this adapter Contax and Nikon wide angle and telephoto lenses can be used for close-up photography

Rubber Eye Cup for Eye-Level Pentaprism and Chest-Level VF 3 Viewfinders

Eye Sight Adjuster for Eye-Level Pentaprism and Chest-Level VF 3 Viewfinders

Lens Hoods (all lenses)

Body Cap

Back Lens Cap

AUTOMEX ACCESSORIES



## List of MIRANDA Lenses

### AUTOMEX Lenses

- 28 mm f : 2.8 Ultra Wide-Angle 8-element construction
- 35 mm f : 2.8 Wide-Angle 7-element construction
- 50 mm f : 1.9 Normal 6-element construction
- 105 mm f : 2.8 Medium Telephoto 6-element construction
- 135 mm f : 2.8 High Speed True Telephoto 6-element construction
- 135 mm f : 3.5 True Telephoto 6-element construction

### Lenses For All Models

- 28 mm f : 2.8 Wide-Angle Fully Automatic 8-element retrofocus construction
- 35 mm f : 2.8 Wide-Angle Fully Automatic 7-element retrofocus construction
- 35 mm f : 3.5 Wide-Angle Preset 6-element retrofocus
- 50 mm f : 1.9 Normal Automatic 6-element fully corrected
- 50 mm f : 2.8 5-element preset normal
- 105 mm f : 2.8 General Purpose Telephoto 5-element construction
- 135 mm f : 3.5 Short barrel telephoto
- 135 mm f : 3.5 Preset 5-element true telephoto
- 135 mm f : 2.8 Preset 5-element telephoto
- 135 mm f : 3.5 Telephoto Automatic 6-element true telephoto
- 135 mm f : 2.8 Telephoto Automatic 6-element true telephoto
- 250 mm f : 4.5 Telephoto Preset
- 400 mm f : 5.5 Telephoto Preset with orienting tripod socket at center of gravity and filter slot and holder with deluxe leather case

## AUTO-MIRANDA LENSES



Miranda  
Wide Angle Lens  
f : 2.8 35 mm  
focal length



MIRANDA  
TELEPHOTO LENSES



Miranda  
Wide Angle Lens  
f : 2.8 35 mm  
focal length



f : 2.8 105 mm  
focal length



f : 2.8 135 mm  
focal length



f : 3.5 135 mm  
focal length

# CARE OF YOUR CAMERA

## Storage

Keep your MIRANDA in a cool, dry ventilated place.

Do not store in a closed cabinet under humid conditions.

Never store in a humid place, such as a basement, particularly during rainy seasons.

If it is to be stored for some time, remove your MIRANDA from the everready case, and put it in a sealed container along with a drying agent such as silica gel. Do not permit the drying agent to come into direct contact with the camera body.

If an air conditioned room is available, keep it there.

## Protection against Dirt, Dust, and Salt Spray

When your MIRANDA is used out-doors it will in time pick up a certain amount of dust which should be regularly removed with a soft brush or air blower. On board a ship or at the seaside, your MIRANDA should be protected from contact with salt water spray. If your camera is exposed to salt spray, clean the metal and leather parts with a soft, clean cloth, moistened with alcohol or ether.

If no alcohol or ether is available, water can be used if the cloth is first vigorously wrung out. The glass surface of the lens should never be touched with a finger since the slightest touch will leave finger prints which will in time seriously injure the lens. Dust should be removed from the lens with an air blower (an ear syringe purchasable at drug stores is good). Finger prints and stubborn dirt should be removed with a photographic lens cleaner and lens cleaning paper.

The mirror is front surfaced and the reflective coating is very delicate. It should never be touched. It should be cleaned only with an air blower.

# MEMORANDUM OF YOUR CAMERA

CAMERA NUMBER 626515

LENS NUMBER 460992

Exclusive United States Importer :

ALLIED IMPEX CORPORATION

300 Park Avenue South, New York, N.Y. 10010

5201 West Jefferson Boulevard, Los Angeles, California 90016

3740 West Morse Avenue, Chicago, Illinois 60645

1328 Motorcircle, Dallas, Texas 75207



**MIRANDA**