

NIKON SP

CAMERA REPAIR

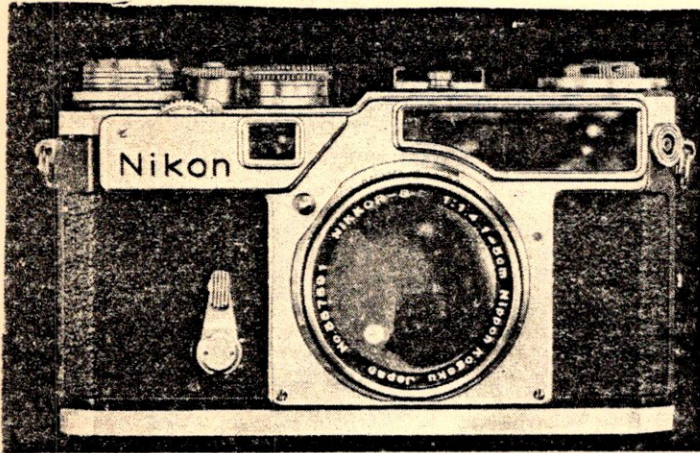

COMPILED FROM FACTORY DATA
WITH AN INTRODUCTION BY ED ROMNEY

COPYRIGHT © 1984 E. Romney

REPRODUCTION FORBIDDEN

CONTENTS

Removal of top cover	1
Removal of front cover	2
Removal of bottom cover	2
Removal of middle plate	3
Adjustment of focusing mechanism	4
Adjustment of flange-focal distance	5
Adjustment of range-finder	6
Removal of range-finder assy	6
Adjustment of finder parallax	8
Removal of picture frame counter	8
Repair of picture frame counter	9
Adjustment of high speed shutter	10
Adjustment of slow speed shutter	14
Removal of governor	14
Adjustment of flash synchronization	15
Replacement of shutter curtains	17
Repair of camera back	20
Picture Plates	21 to 33

DATA HERE WILL ENABLE YOU TO FIX
MOST OTHER NIKON RF CAMERAS, TOO

**ROMNEY • BOX 5247
SPARTANBURG, SC 29304**

INTRODUCTION BY ED ROMNEY

We chose the Nikon SP because of its advanced design and many features. It is identical to S3 except for the rangefinder/viewfinder so our readers will have no trouble with it...or with the earlier Nikon RF cameras which have many similarities, too. Basically, the camera is a Leica in its shutter design and a Contax in appearance and focussing system design. Shutter is a conventional two-curtain cloth with a drum. It gives little trouble. Older cameras are frequently found with stiff or erratic focussing mounts. The instructions tell how to correct this problem by cleaning the helix.

The manual assumes the reader is familiar with basic camera repair. If not, it is advisable to study our very popular BASIC TRAINING IN CAMERA REPAIR first. Special tools are mentioned. The person who does not repair Nikon SP regularly will improvise them by making an adjustable small spanner out of a pair of scissors by filing the points to fit and putting a wing nut in the center. A leather belt around a pair of pliers will usually loosen round parts. Use another known good camera as a standard for adjusting body depth or use our popular optical backsighting method.

One of the biggest problems in amateur Nikon RF repair is getting dirt on the optics. They magnify it greatly. Clean with staticmaster brush and clean lint-free rags and a solution of ether and alcohol being careful NOT to get it on the painted parts.

One big risk with a camera as valuable as these is cosmetic damage during a repair which can easily reduce it to a VG condition. Be careful there is nothing metal on your bench when you place the camera that can scratch the bottom. Be sure your screwdrivers are all sharp and they fit the screws exactly. Use a Vision visor magnifier always so you can see well enough so you will not slip. Hold your fingers near the end of the screwdriver so you will not gouge trim parts when you take out or insert screws. It would be hard to find a parts camera you can remove parts from to repair cosmetic damage. Buy water soaked non-working cameras for this purpose. You can still get, as this is written, some parts from the Nikon Parts Dept at 623 Stewart AVE Garden City, NY 11530. Their fine service has helped give all the Nikon cameras the excellent reputation they have in the USA. You can order tools, lubricants, cleaning solution, cements and abrasives as well as texts on most other Nikons and other fine cameras from Romney at the address on the cover. Brookstone Corp. at Vose Farm Rd. Peterborough NH 13458 also sells interesting tools you will like, fine catalog. We do not sell parts for specific cameras but we do have assortments of chrome and machine screws that will fit this and other metric thread cameras. We wish you all possible success in repairing restoring, collecting and investing in classic Nikon cameras.

Spartanburg SC 29304 USA

Edward H Romney

1) REMOVAL OF TOP-COVER

=====

(See Fig. 3)

1. Remove the camera back.
2. Remove the rewind knob.
 - a. Erect the crank No. 552 and loosen the inside screw No. 573.
 - b. Unscrew the rewind knob No. 551 by turning it counter-clockwise, as you hold the rewind fork No. 570.
3. Removing the finder selector dial.

Unscrew two screws No. 21 and take off the dial No. 555.
(Preferably setting figure 13.5 at the index)
4. Removing the shutter dial
 - a. Unscrew the screw No. 258
 - b. Take off the dial No. 251 together with the knurled ring No. 252.
 - c. The dial spring No. 255 and the spring washer No. 256 can be removed together.
5. Removing the A=R ring
 - a. Loosen the set screw No. 436 which can be seen through the hole on the side of the ring.
 - b. Using a forked screw driver, unscrew the inside retainer No. 387.
 - c. The A=R ring No. 389, the release button No. 386 and the button stopper No. 388 can be removed.
6. Removing the winding lever
 - a. Loosen three set screws No. 436 and then remove the index ring No. 428.
 - b. Take off remainder sector No. 591 and the dial base No. 593.
 - c. Remove the winding lever No. 444 together with the adjusting ring No. 595.

7. Removing the top-cover retainer

Take off the retainer No. 443 by revolving it counter-clockwise with a screw driver.

8. Removing the flash-gun outlet in front of the finder shoe.
Revolve the outlet No. 712-714 counter-clockwise using a special tool.

9. Unscrewing the top-cover screws

Unscrew two screws No. 560 located under the finder selector dial.

10. Now remove the top-cover No. 3.

Remarks: 1 Occasionally, the top-cover is stuck slightly to camera body by glue used for leathering.

2 There is no difference regarding the order which may be taken for disassembly stated in paragraphs 3 to 8.

2) REMOVAL OF FRONT-COVER

(See Fig. 1)

1. Unscrew the screws No. 25 located on the side and on the front of the cover.
2. Take off the front-cover slowly, holding both sides of the cover and moving slightly right and left.

Remarks: Locate the distance scale of the focusing mount assembly at any distance other than infinity, otherwise the hole edge of the focusing wheel may be damaged.

3) REMOVAL OF THE BOTTOM COVER

(See Fig. 5)

1. Remove the camera back.
2. Unscrew four screws No. 22
3. Take off the bottom cover No. 7.

4) REMOVAL OF THE MIDDLE PLATE

=====

(See Fig. 4)

The removal of the middle plate described below should not be attempted as possible except for the following occasions, because of taking much time for reassembly:

- (1) When repairing the lower safety device
 - (2) When repairing the drum connector
 - (3) When a particular derangement in the shutter curtain running should be repaired.
1. Remove the top-cover (See p. 1)
 2. Remove the front-cover (See p. 2)
 3. Remove the governor (See p. 15)
 4. Loosen the set screw No. 393 on the boss No. 322 of the lever No. 306 located on the governor switching shaft (See Fig. 6)
 5. Remove the shutter index
 - a. Loosen the set screw No. 257 through the hole created on the side of the shutter click plate No. 265.
 - b. Remove the shutter winding index No. 254
- Preferably take the above procedures a and b in the state of the shutter dial set at 1/2 and of the shutter wound up.
6. Unscrew two screws No. 329 and the screw No. 423 on the middle plate.
 7. Removing the slow lever No. 299
 - a. Unscrew the slow lever shaft screw No. 300, taking care that the slow lever shaft No. 297 and the slow lever spring No. 298 will be removed together simultaneously.
 8. Removing the middle plate

Pull up the middle plate, turning aside the upper governor switching lever No. 305.

5) ADJUSTMENT OF FOCUSING MECHANISM

1. Unsmoothness or unevenness of focusing screw threads

In most cases it is due to dust having found its way into the screw thread.

- a. Remove the front cover (Fig. 1)
- b. Remove the focusing mount (See "Removal of Governor" p. 15)
- c. Remove the thread stop No. 78 (Fig. 2) after unscrewing two screws No. 79 (Fig. 2)
- d. Dismantle the focusing screw threads and clean them with Gasoline (Never oil them thereafter)

2. Adjustment of infinity lock

If the infinity lock No. 70 (fig. 2) is deformed by some accident, adjust it the following way:

- a. Remove front cover No. 2
- b. Remove the focusing mount
- c. Reshape the contact point of lock No. 70 by filing away or beating up.

3. Unsmoothness or unevenness of the focusing wheel.

A. The focusing wheel No. 59 and the third gear No. 63 are not correctly into gear with the second gear No. 62.

- a. Remove the top-cover (See p. 1)
- b. Remove the front-cover No. 2
- c. Unscrew the front two of the screws No. 423 on the base plate of the finder-shoe (Fig. 1)
- d. Tear of the leather on the self-timer side.
- e. Unscrew the outer sided two (Fig. 1 and 6) of four screws No. 30 on the self-timer mount.
- f. Unscrew the front-plate attaching screw No. 423 and four screws No. 449 (Fig. 1 or 6).
- g. The front-plate No. 6 together with the focusing mount and self-timer can be removed.

- h. Improve the gearing behind the front plate by turning 2 screws No. 469 on the third gear bearing (Fig. 7). In this case, take care of the positions of the focusing mount No. 53 and the second gear No. 62 (Fig.7).

Remarks: Cleaning the gears and the shafts with gasoline and oiling them will sometimes suffice before the above procedures are taken. If necessary replace the gears and shafts.

- B. Improper relative positioning of the focusing wheel and the focusing mount may sometimes give rise to unsmoothness or unevenness of the focusing wheel.

Adjust the engagement of the focusing thread No. 53 with the third gear No. 3 according to the previous paragraph.

6) ADJUSTMENT OF FLANGE-FOCAL DISTANCE

=====

(See Fig. 2)

1. Remove the camera back
2. Set the shutter dial at T and let the shutter curtain open.
3. Check the flange focal distance using a dial indicator.

If the distance is found incorrect:

4. Remove the front-cover.
5. Remove the focusing mount (See p. 4)
6. Replace the liner No. 81 of proper thickness (Fig. 2).

7) ADJUSTMENT OF RANGE-FINDER

(See Fig. 1 & 17)

A. Adjustment of vertical error in coincidence

1. Remove the front cover (See p. 2)
2. Thrusting a screw driver through the slit between the front-plate No. 6 and the top-cover No. 3, loosen the screw No. 210 fastening the rotating wedge prism mount No. 193.
3. Using the end of a screw driver through the slit A, turn the knurled edge of the rotating wedge prism mount No. 193.

B. Adjustment of horizontal error in coincidence

1. Remove the front-cover (See p. 2).
2. Thrusting a screw driver through hole B on the front plate No. 6, move the adjusting screw No. 177.

Clockwise rotation of the driver will advance the coincidence beyond infinity.

C. Adjustment of range finding accuracy (Fig 4 & 17)

1. Remove the top-cover (See p. 1)
2. Remove the front-cover (See p. 2)
3. Remove the synchro safty contact, leaving the cord attached (See p. 8)
4. Remove the finder-shoe mount (See p. 8)
5. The accuracy can be obtained by properly combining the rotations of the double excenter ring No. 164 and No. 165.

8) REMOVAL OF RANGE-FINDER ASSEMBLY

The removal of the range-finder assy described below should be attempted only when the rangefinder can not be adjusted by the procedures 7) A and B

To remove the range-finder assembly:

1. Remove the top-cover (See p. 1)
2. Removing the synchro dial
 - a. Unscrew two screws No. 332 (Fig. 6)
 - b. Remove synchro dial No. 263
3. Removing the rewinder mount (Fig. 3)
 - a. Unscrew three screws No. 31
 - b. Remove the rewinder mount No. 5
(The finder cam and rewinder gear will be removed together)
4. Remove the front-cover (See p. 2)
5. Removing the large window glass (Figs. 1 & 4)
 - a. Unscrew four screws No. 206
 - b. The large window frame No. 197, the large window glass G 10 and the large window plate No. 198 can be removed together.
6. Remove the upper gear No. 564 on the rewind idler shaft (Fig. 4)
7. Unscrew two screws No. 704 fastening the synchro safety contact (Fig. 4)
8. Unscrew two screws No. 423 and the screw No. 499 on the finder shoe (Fig. 4). In taking the above procedures 8 and 9, detachment of the synchro wiring is not necessary.
9. Removing the wide-angle-finder objective barrel (Fig. 4)
 - a) Unscrew two screws No. 219
 - b) Pull out the objective barrel No. 218 of the wide-angle finder hole on the front plate No. 6.
10. Removing the eyepiece window (Fig. 4)
 - a) Tear off the leather on both sides of the eyepiece.
 - b) Unscrew the screw No. 200 and two screws No. 205 on the eyepiece.

Note that the left side one No. 200 of the above screws is secured by the nut No. 209 on the backside.

- c) The eyepiece window No. 217 and the eyepiece mask No. 228 are removed together.
11. Unscrew three screws No. 423 on the range-finder
 12. Remove range-finder assy by pulling it up. (Fig. 4)
 13. Remove the lower rewind idler gear No. 566 (Fig. 4)

Take care of the washer No. 490 which is occasionally used for adjustment.

9) ADJUSTMENT OF FINDER PARALLAX

1. Remove the camera back and the top-cover (See p. 1)
2. Remove the front-cover (See p. 2)
3. Remove the synchro safety contact, leaving the cord attached.
4. Remove the finder-shoe mount. In this state, attach the camera lens and place a ground glass screen on the film plane. Checking the test-chart image on the screen, make the adjustment the following way:
 - a. Turn the parallax lever adjusting screw No. 161 (Fig. 17).
 - b. Move the frame plate No. 152 after loosening two screws No. 202 (Fig. 17)

10) REMOVAL OF PICTURE FRAME COUNTER

(See Fig. 3 & 4)

1. Unscrewing the setscrew No. 428, remove the counter ring No. 428 (Fig. 3).
2. Remove the film load reminder sector No. 591 and its mount No. 593 (Fig. 3).
3. Remove the C-shaped counter clip No. 429 (Fig. 4).
4. Remove the counter dial No. 430, the spring No. 432 and the counter ratchet No. 431 together, taking care of sudden releasing of the spring.

5. Unscrew the screw No. 270 fastening the counter seat No. 593.
6. Unscrew the stop screw No. 434. The collar No. 435 will be removed together.
7. Take off the counter seat No. 433.
8. Remove the excentric disc No. 441 on the top of the shaft by turning it clockwise.
9. Remove the pawl No. 438.
10. Remove the washer No. 427.

11) REPAIR OF PICTURE FRAME COUNTER

=====

A. The counter does not return to its start

1. Vertical movement of the dial shaft is not smooth.

The shaft No. 483 should move smoothly according as the camera back is attached or detached. If it does not, adjust the strength of the springs No. 486 and No. 487 (Fig. 20).

2. Counter dial does not turn correctly

- a. If the fitting of the dial clutch No. 431 to its shaft No. 590 is too tight, make it loose by reaming the hole.
- b. If the dial No. 430 is secured by C-shaped clip No. 429, file off slightly the upper surface of the dial clutch No. 431.
- c. If the dial touches the film load reminder No. 591 or its index ring No. 428 (Fig. 3), make the dial No. 430 flat and level.

3. Height of the catching pawl is not correct

Bend the pawl No. 438 slightly down, if the end of the pawl touches the dial clutch No. 431 even when the dial shaft No. 483 is lowered.

B. The counter does not advance correctly (Fig. 4)

1. Height of the counter dial shaft is not correct.

The camera back being attached, check whether the counter dial shaft is sufficiently raised.

If not, repair camera back and the shaft.

2. Height of the pawl No. 438 is not correct

Bend the pawl No. 438 so that the pawl couples with the dial clutch No. 431 correctly.

3. Moving range of catching pawl No. 438 is not sufficient.

Replace the eccentric shaft No. 441.

12) ADJUSTMENT OF HIGH SPEED SHUTTER

=====

(1/60 - 1/1000 Sec.)

In shutter adjusting, start with the easiest of the procedures described below, according to the derangement confronted.

A. Shutter speed

Error in high speed times (1/60 - 1/1000) should be corrected by changing the tension of the front curtain and not of the rear curtain, since by adjusting the rear curtain the slow shutter speeds may also be affected.

1. Remove the bottom cover (Fig. 5)

2. After loosening the set screw No. 393 turn the tension worm gear No. 362 so that the correct curtain speed 14.5 milliseconds is obtained at 1/60 setting.

Remarks: 1. Tension will be strengthened by revolving the worm clockwise.

2. A special measuring device is needed for checking the above running speed 14.5 milliseconds. However, the device is dispensed with, when the following method is taken:

See if the whole film aperture is uniformly illuminated by a speed light or neon tube when the light is synchronized with the camera exposure with synchro-selector set at X.

If not, adjust the speed according to the following:

3. Remove the top-cover (See p. 1)
4. Attach the winding lever No. 444 and also the shutter dial No. 251 with the screw No. 258.
5. Remove the safety contact after unscrewing two screws No. 704.
6. Adjust the speed 1/60 by changing the excentricity of screw No. 287 A, after loosening the lock nut 287 B (Fig. 14)

Remarks: Clockwise turning of the screw 287 A will prolong the shutter time.

If the shutter not faster than 1/500 can not be corrected by the above procedures, take the following method:

7. Adjust he speed 1/500 by changing excentricity of the screw No. 283 - C (Fig. 14).
8. Check the speeds 1/60 and B, since the above adjustment may occasionally cause the derangement of these two speeds, if the adjustment is made to wide extend.
9. Adjust the speed 1/1000 by pressing or pulling the tongue of the high speed cam No. 268 (Fig. 14).

Pressing the tongue will prolong the shutter time of 1/1000 second.

B. Exposure uniformity

The slit width of the shutter curtains should be kept uniform during its travel along the film aperture. If it does not, adjust it as follows:

1. When the slit becomes narrower at the end of its travel than at the beginning:

- a. Spring tension is not adequate (Fig. 5)

Adjust tension of the front curtain (not of the rear curtain possibly) according to the procedures described in the previous section A.

- b. Too much friction is effected upon the escapement cam.

Remove the range-finder assy, and oil the cam No. 273 (Fig. 14).

- c. Strength of the escapement lever spring No. 289 is too strong (Fig. 14).

Weaken it but not too much, otherwise the shutter speed would become unstable.

2. When the slit becomes wider at the end than at the beginning

a. Spring tension is not correct (See Fig. 5).

Adjust it by the front curtain (See the previous description).

b. Revolution of the drum connector is too heavy (Fig. 20)

Replace the drum connector according to the following:

(1) Remove the middle plate (See p. 3).

(2) Take off the synchro cam No. 274, after pulling out the taper pin No. 245.

(3) Unscrew three screws No. 281 on the drum bearing part No. 280.

(4) Drum subassembly, consisting of the drum No. 280, drum connector No. 276, the ball bearing No. 279 and the pawl No. 275 etc. can now be removed.

Replace it.

C. Shutter consistency

Unstable shutter speed is corrected in the following way:

1. If the light baffle cloth contacts with the curtain, the attached position of the baffle should be corrected as follows: (See Fig. 6)

(1) If the lower part of the baffle touches the curtain,

a. Remove the camera back

b. Remove the bottom cover

c. Shift the place of the baffle No. 9, after loosening the set screws No. 21.

(2) If the upper part of the baffle cloth touches the curtain,

a. Remove the range-finder assembly (See p. 6).

b. Shift the place of the baffle No. 9 after loosening two screws No. 21.

In both cases (1) and (2) take care of the relationship of the baffle to the focusing mount.

2. If the strength of tear-drop lever spring is not proper,
 - a. Remove the middle plate (See p. 3)
 - b. Adjust the strength of the spring No. 289 (Fig. 14).
3. If loosening of the shutter speed dial occurs (Figs.3,4,20)
 - a. Unscrew the screw No. 258, remove the shutter dial No. 251.
 - b. Remove the knurled ring No. 252.
 - c. Remove the shutter wind index No. 254 (See "Removal of middle plate" p. 3).
 - d. Unscrewing two screws No. 259, remove the click wheel No. 265.
 - e. Remove the click spring No. 261 and bend it to strengthen spring action.
4. If the lower idler gear No. 354 is not correctly in gear with the lever No. 418, since it causes unstable starting, adjust it by shifting the place of gear No. 354 (Figs 5,20)
5. If the escapement spring is deformed, correct it as follows (Fig. 3):
 - a. Remove the top-cover
 - b. After unscrewing the escapement spring screw No. 323, remove the escapement spring No. 313 and correct its form.
6. If smooth movement of the spring No. 308 is hindered, it may be due to deformation of the spring or too tight fitting of the shaft to the escapement.

In the latter case adjust it as follows:

 - a. Remove the middle plate (p. 3)
 - b. Remove the escapement No. 308 (Fig. 14)
 - c. Thrust a reamer through the bearings No. 314 (Fig. 20)
 - d. Remove the camera back
 - e. Remove the bottom cover (p. 2)
 - f. Remove the plate spring No. 421 after unscrewing two screws No. 423 and No. 420 (Fig. 5)
 - g. Thrust a reamer through the shaft spring holes.

13) ADJUSTMENT OF SLOW SPEED SHUTTER

=====

(1/30 - 1 Sec)

A. Shutter speeds (Figs. 3, 6, 13)

1. Remove the top cover
2. Attach the winding lever No. 444 only
3. Attach the shutter dial No. 251 with the screws No. 258
4. Adjust the slow speeds by changing excentricity of the slow lever No. 301 and of the slow lever shaft No. 297.

Remarks: Adjustment of the lever is to be done only for the speed $\frac{1}{4}$. Adjustment of the lever shaft is to be done for the mean errors of all the other speeds 1, $\frac{1}{2}$, $\frac{1}{4}$,

In case of repairing it is not advisable to shift the starting or attached position of the governor No. 501 - 536.

14) REMOVAL OF THE GOVERNOR

=====

(See Figs. 2 and 6)

1. Remove the camera back
2. Remove the front cover (See p. 2)
3. Remove the focusing mount assembly
 - a. Unscrew the screw No. 80 and two screws No. 82 fastening the mount.
 - b. Take off the focusing mount assembly

In this case take care of the relationship of the infinity lock lever to the focusing wheel.

- c. Take off the liners No. 81 located between the focusing mount and the camera body, identifying them for reassembly.
4. Removing the light baffle (Fig. 2)
 - a. Unscrew two screws No. 281
 - b. The light baffle No. 10 can now be taken off.
 5. Remove the bottom cover -
 6. Removing the governor
 - a. As you hold the camera body and the governor with the left hand, unscrew two governor fastening screws No. 329 from underneath.
 - b. Placing the body on the desk, take out the governor with a tweezer, taking care of the relationship of the lever No. 294 to the lower changing lever No. 306.

Remarks: 1. It is better to set the shutter speed dial at $\frac{1}{4}$, $\frac{1}{2}$, or 1.

2. Take care not to deform the governor switching lever No. 306 when taking out the governor.

15) ADJUSTMENT OF FLASH SYNCHRONIZATION

=====

If synchronization does not work properly, the following inspection and adjustment is necessary:

A. Insulation (Fig. 15)

1. Either of the terminals (the one located in front of the finder shoe or the other on the camera side and to be connected to flash gun cord) should be insulated from the camera body, when the shutter button is popped up, no matter whether the shutter has been wound up or released.

If not, replace the insulator as follows:

(1) Flash outlet in front of the finder shoe

Pull out the nylon insulator located inside the outlet and replace it.

(2) Side terminal to be connected to flash gun cord

- a. Remove top-cover (See p. 1)
- b. Remove the rewinding base No. 555 (Fig. 3)
- c. Loosen the set screw No. 24 (Fig. 4)
- d. Take off the connecting wire of the terminal
- e. Unscrew the terminal No. 708 - 718 by turning it counterclockwise and replace it.

2. Safety contact (Fig. 15)

If the attaching screw No. 704 contacts with the contact plates No. 700 and No. 701, insert the insulator collar No. 703 correctly.

3. Electric wiring system (Fig. 15)

Replace the wiring system

B. Conductivity (Fig. 15)

After releasing the shutter, hold the shutter releasing button depressed. While doing this, see if the flash circuit is closed or not.

If not, check the following points:

1. Either of the flash terminals (the one located in front of the finder shoe or the other found on the camera side and to be connected to flash gun cord).

If any fault is found in its conductivity, replace it.

2. Spring of the safety-contact plate

In case the strength of the spring is found too weak, make strong by bonding it more.

C. Time lag (Fig. 15)

The shutter curtain travel and flash circuit closing should take place after another in conformity with the following sequences:

1. The synchro-selector being set at the green dot, the time passed between the flash circuit closing and the the beginning of the front curtain opening is to be 8/1000th of second.
2. The selector being set at the red dot, the time described above is to be 4/1000 second.
3. The selector being set at the white dot, the flash circuit should be closed at the instant the front curtain reaches the centre of the film aperture.
4. With the selector set at FX and the shutter speed dial set at 1/60, the flash circuit is to be made just before the rear curtain starts its closing action which is preceded by fully opening of the front curtain (X contact).

If synchronization does not work as described above, check and adjust it according to the following:

1. Insufficient conductivity
 - a. Remove the top-cover (See p. 1)
 - b. Bend the synchro-cam lever No. 580 right of left

The cam-lever bending can also be made after removing the lever shaft No. 581 and the lever No. 580.
2. Incorrect positioning of the time-lag controlling contact (See Fig. 4 and 5)
 - a. X contact can be adjusted by turning the excentric pin No. 583 on the middle plate.
 - b. Improper operation of the synchro-running lever No. 575 or detachment of the spring No. 579 is repaired after removing the range-finder.

16) REPLACEMENT OF SHUTTER CURTAIN

1. Remove the top-plate
2. Remove the front-cover
3. Remove the range-finder assembly (See p. 6)

4. Tear off the front leather (the removed leather cannot be used again).
5. Unscrew the outer sided two of the self-timer securing screws No. 30.
6. Unscrew one of the two screws No. 423 and four screws No. 449. Then remove the front-plate, the focusing mount being kept attached (Fig. 6)
7. Remove the bottom cover (See p. 2)
8. Remove the governor (See p. 15)
9. Loosen two set screws No. 393 on the lower changing lever boss.
10. Removing the light baffle No. 9
 - a. Unscrew four screws No. 21
 - b. Then the bottom nut No. 11, the top nut No. 12 and the light baffle No. 9 can be removed together.

After the above disassembly the replacement of the curtain can be done by the following procedures:

1. Replacement of both curtains

The front curtain is to be replaced first, then the rear curtain.

- a. Front-curtain replacement (Fig. 8)

Put first the stripe of front curtain on the pulleys No. 334 and No. 343 of the shutter-drum (Fig. 8). Then put the curtain on the tube-spring No. 374.

The correct position is obtained by adjusting according to Fig. 9 + 10 before the glue dries. Take care not to attach the curtain slantwise, as it would impair the shutter speed accuracy.

At the tripped position and when the breaking mechanism of the front curtain is freed, the space between the edge of front curtain and the edge of aperture plate should be 1.9 - 2mm.

Check the parallelism of curtain according to Fig. 10. Wind up the front curtain by revolving the pulley of shutter-drum with the fingers, in order to get a narrow slit of 0.1 - 0.3mm, and look to the light through this slit. If the light slit is wedge-shape, adjustment is necessary.

- b. Put the strips of rear-curtain on the tube spring No. 371. Then put the curtain on the drum No. 340 (Fig. 11). In this case in order to reach the end of the curtain, use a screw driver instead of the fingers while releasing slightly tension of the curtain after winding it up.

The overlap is checked according to Fig. 12. Bring the both curtains to the middle of the aperture-plate, check the overlap as shown in Fig. 12, which means, the inside metal edge of the curtain should hardly be seen from the film side. To check parallelism, make a narrow slit between (0.1 - 0.3mm) both curtains by winding the shutter partially, and observe the light through this narrow slit. The slit can be made by turning the drum with your finger. If the light slit has a wedge shape, adjustment is necessary.

2. Front curtain only

The procedures described above for both curtains are sufficient. In this case, if the rear curtain is in correct position, replacement of the front curtain can be made relative to the rear curtain so far as overlap and parallelism are concerned.

3. Rear curtain only

The procedures described for both curtains are sufficient. If the front curtain remains in correct position, the rear curtain is aligned using the front curtain for reference.

After replacing the shutter curtains, keep the shutter in the released state about one hour without using the spring in order to prevent the curtains replaced from shifting.

Reassembly of the parts can be done in the reversed procedures, taking care that the light baffle doesn't touch the curtains for fear of impairing the shutter speed consistency (See p. 12).

For replacing the curtain use of the glue "Pliobond" made by Good Year Inc. USA is recommended. Use it according to the instructions given, but it is better to make it slightly thinner.

17) REPAIR OF CAMERA BACK

=====

In case there is a slack in the fitting of the camera back to the camera body, repair is done as follows:

1. Correct misalignment of lock-link No. 603. This damage is caused by turning lock handle when camera back is not properly placed on camera body.
2. When the lock-handle is loose, tighten the screw No. 604.
3. A slight slackness in the fitting of camera back and camera body is removed by bending the end of lock-link No. 603 found at spool end and/or by bending the tongue No. 608 found at the magazine end.

A very slight adjustment is all that is usually necessary.

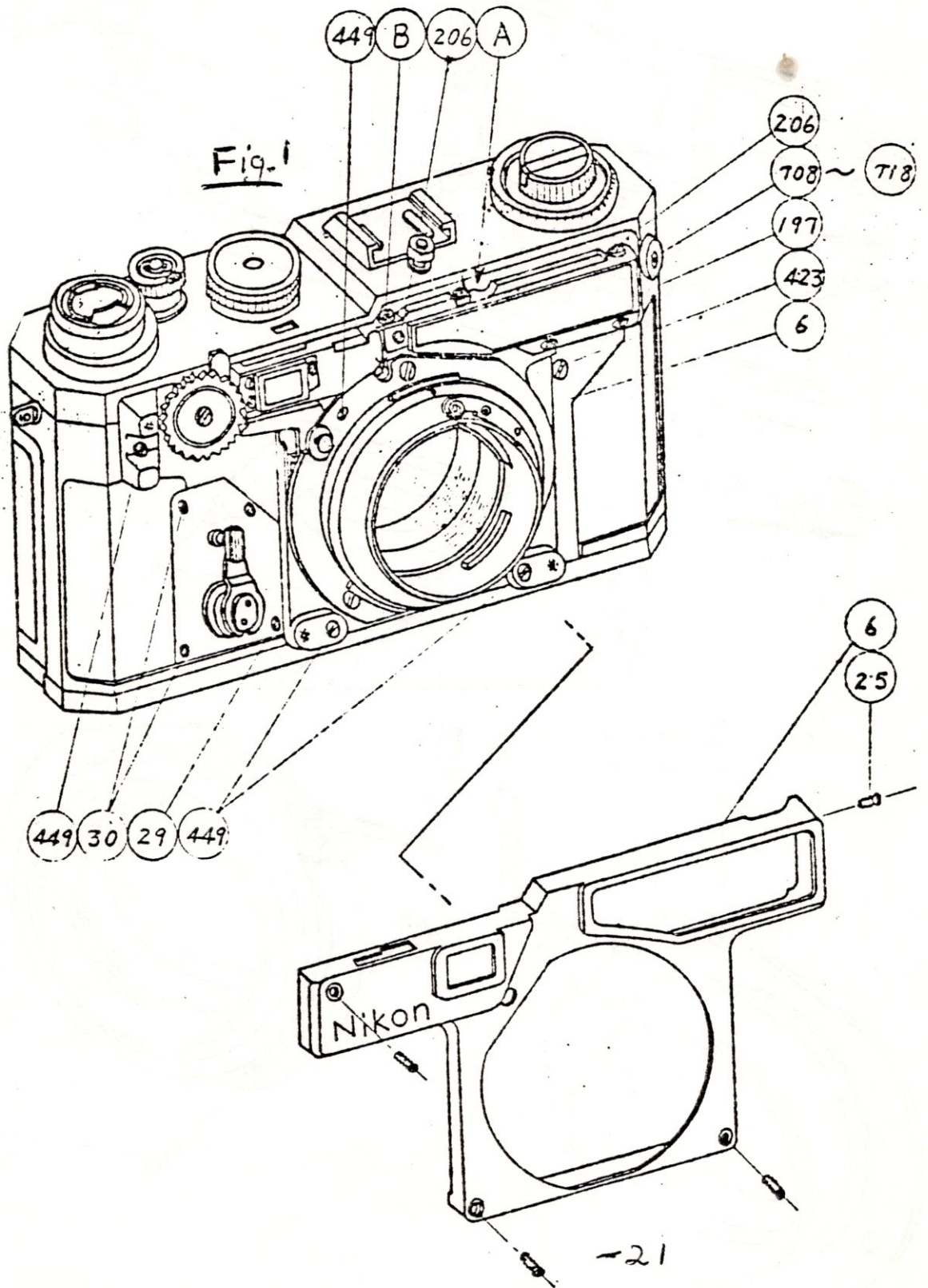

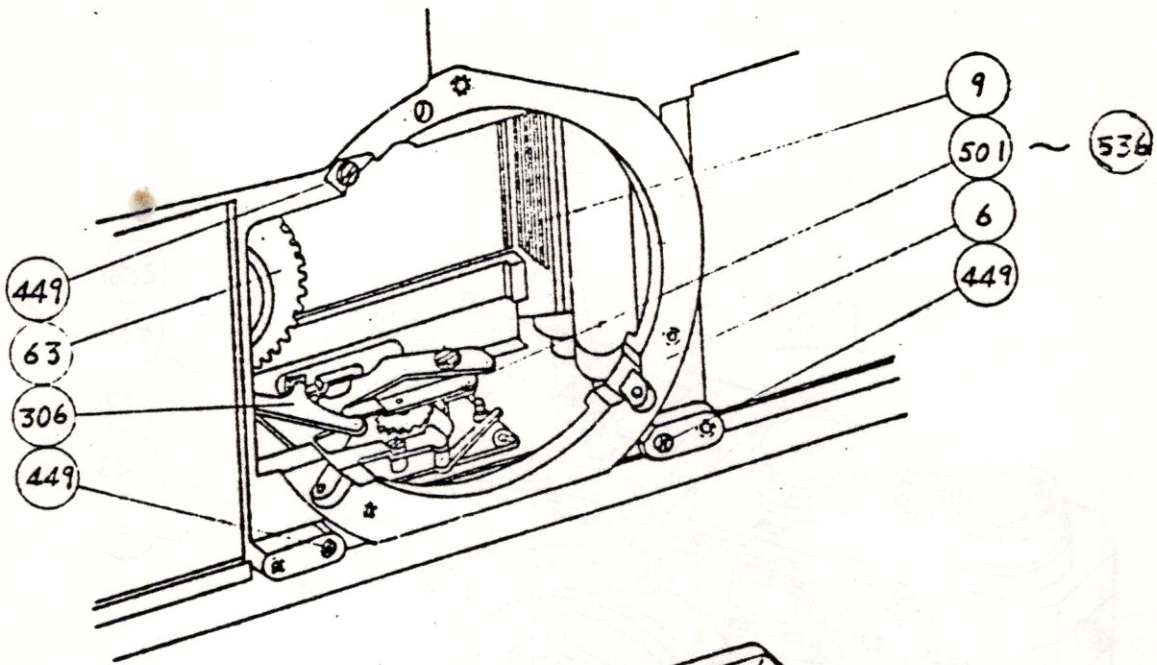

Fig. 2

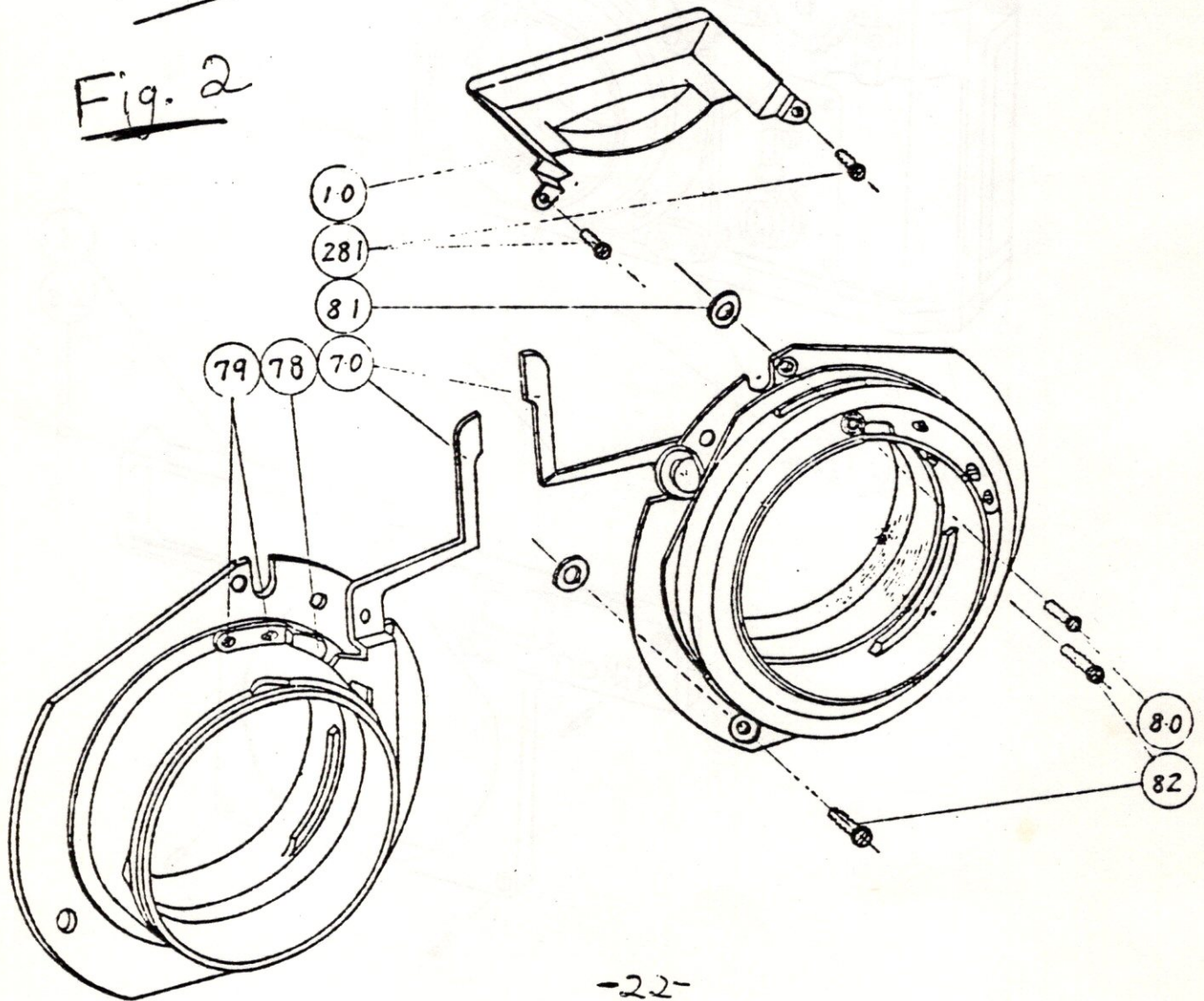

Fig 3

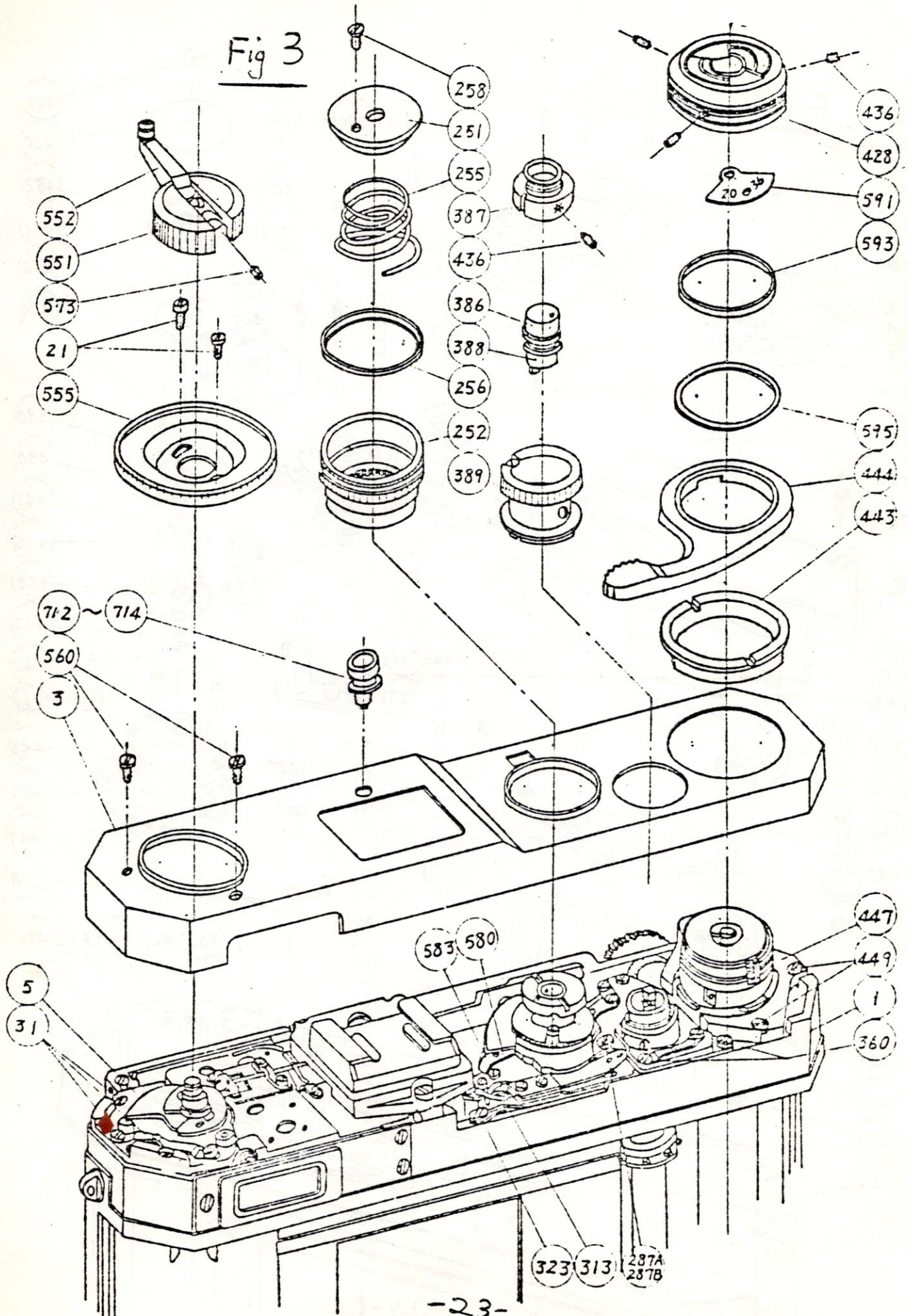
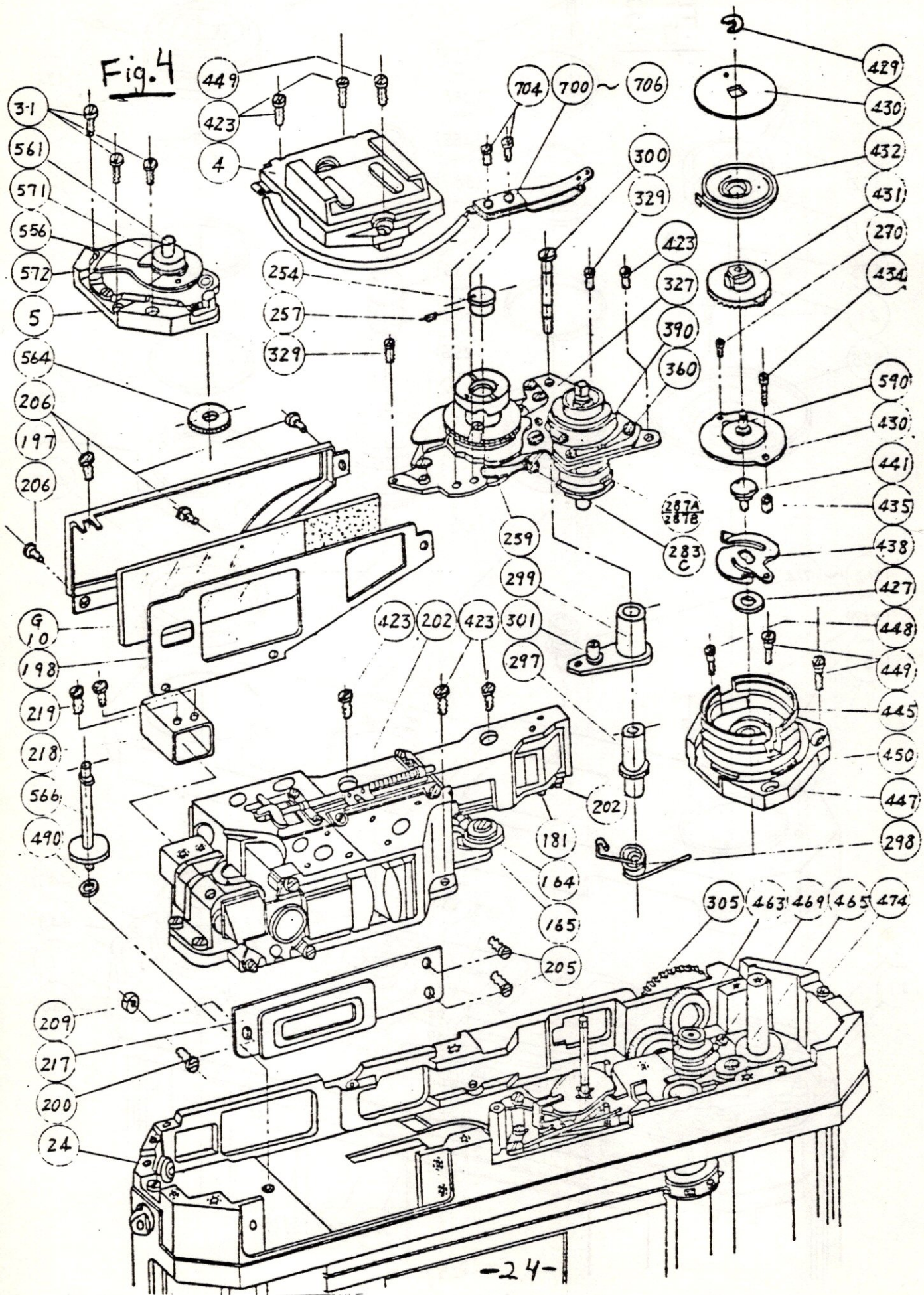

Fig. 4



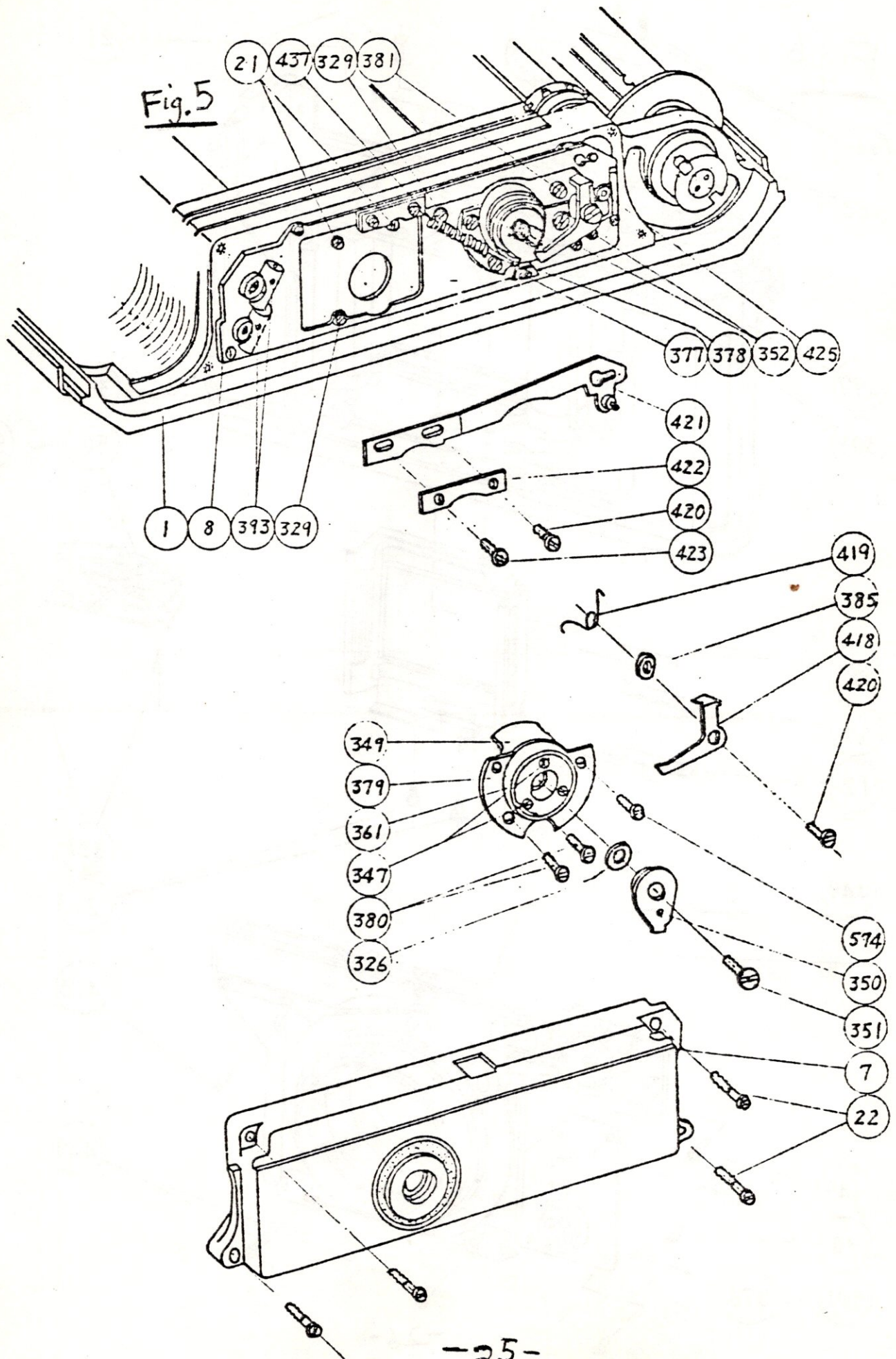
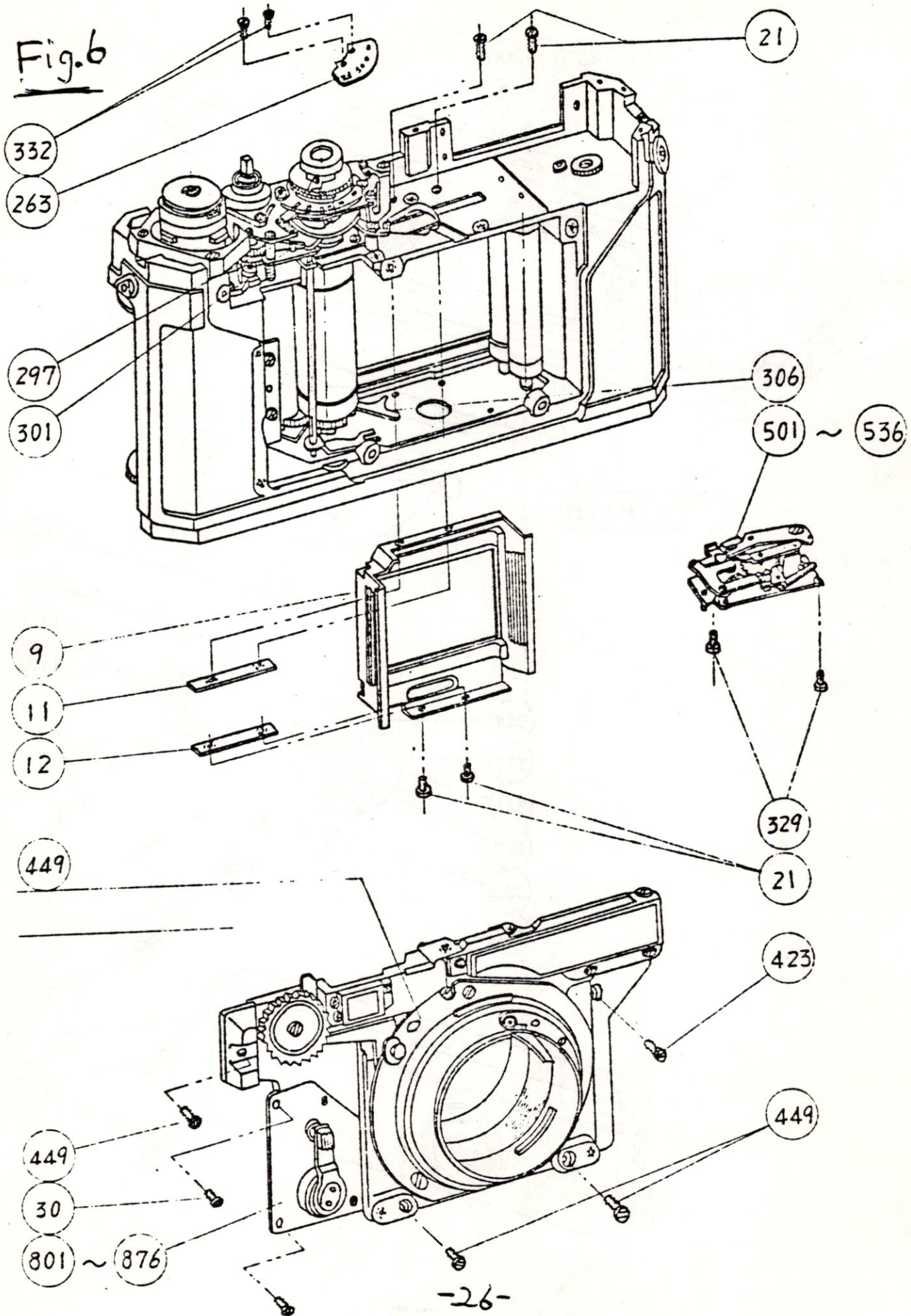
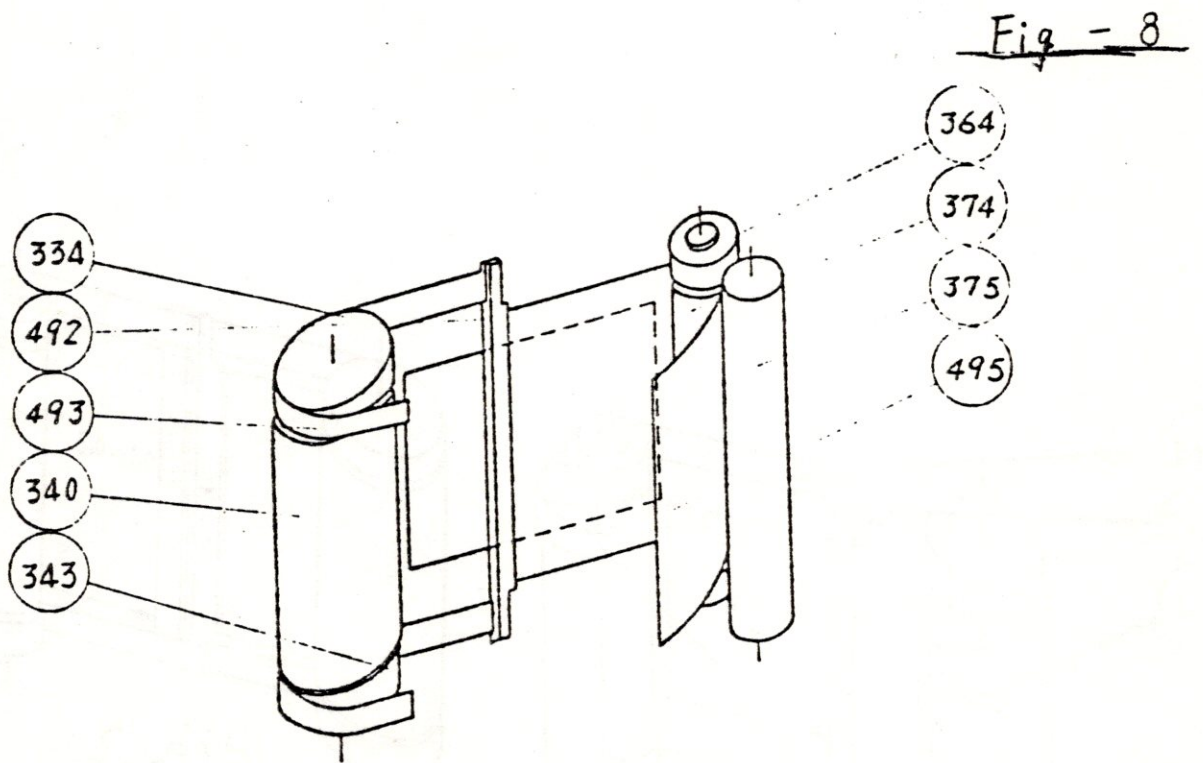
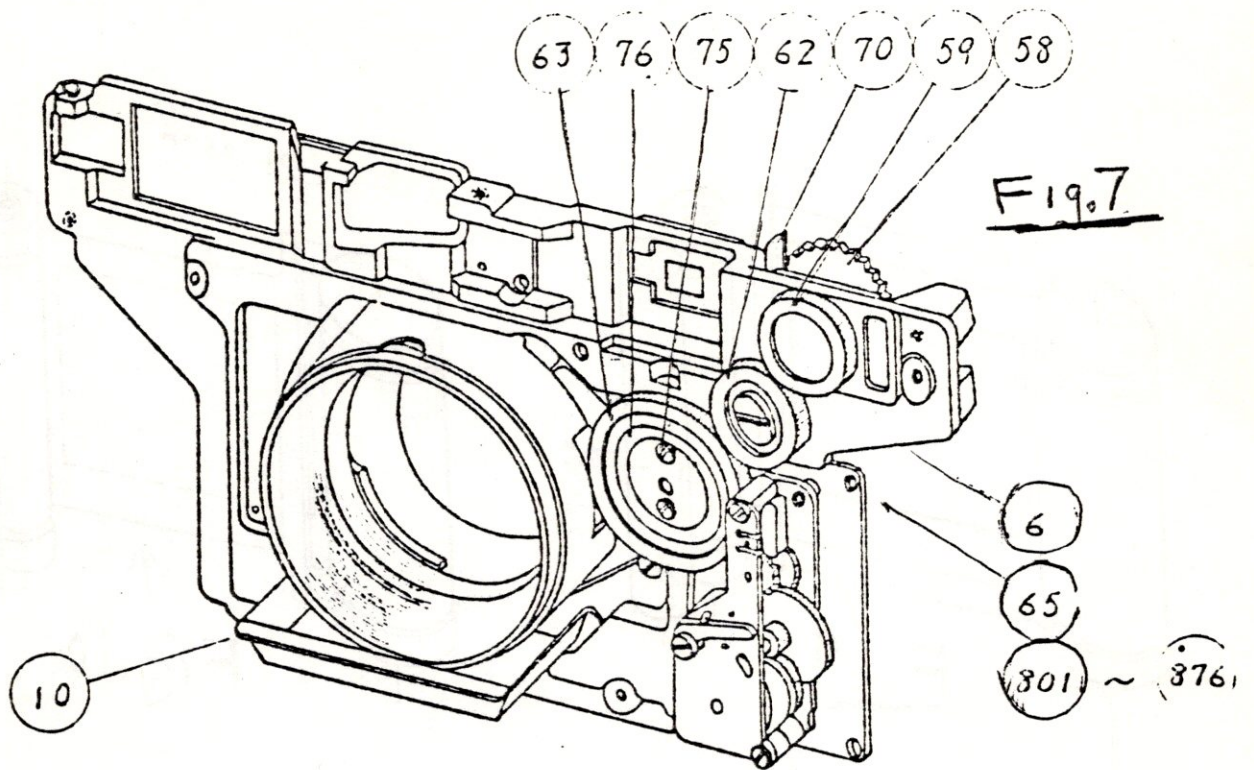

Fig. 6





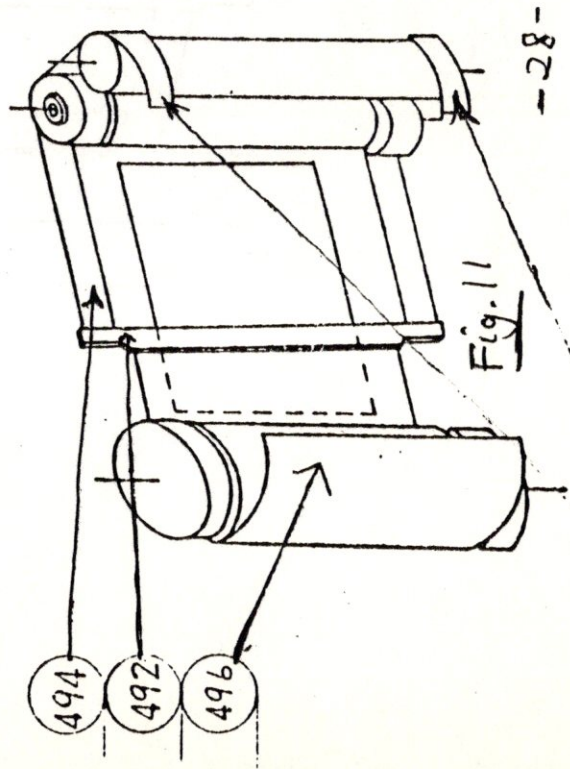
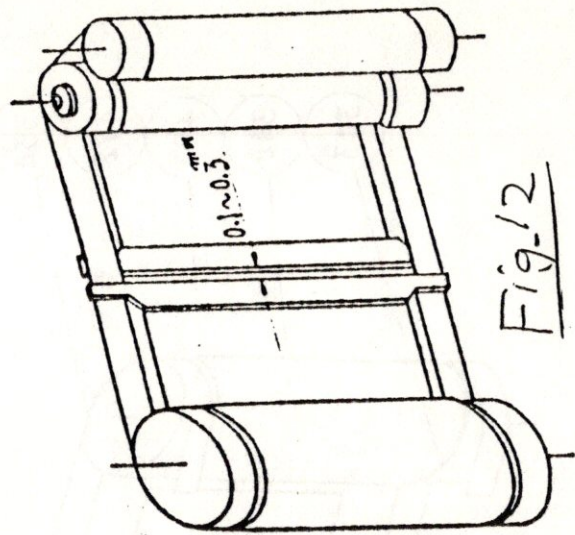
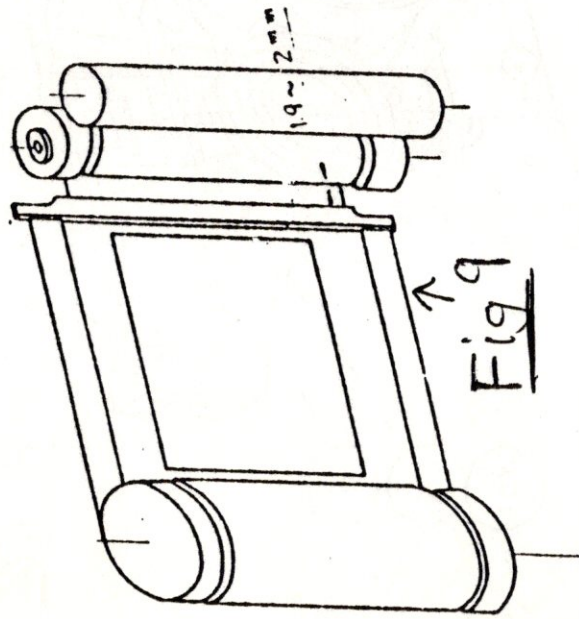
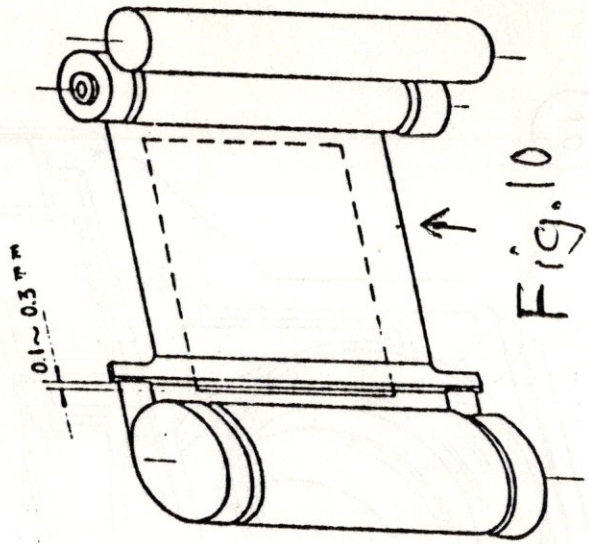

Fig - 13

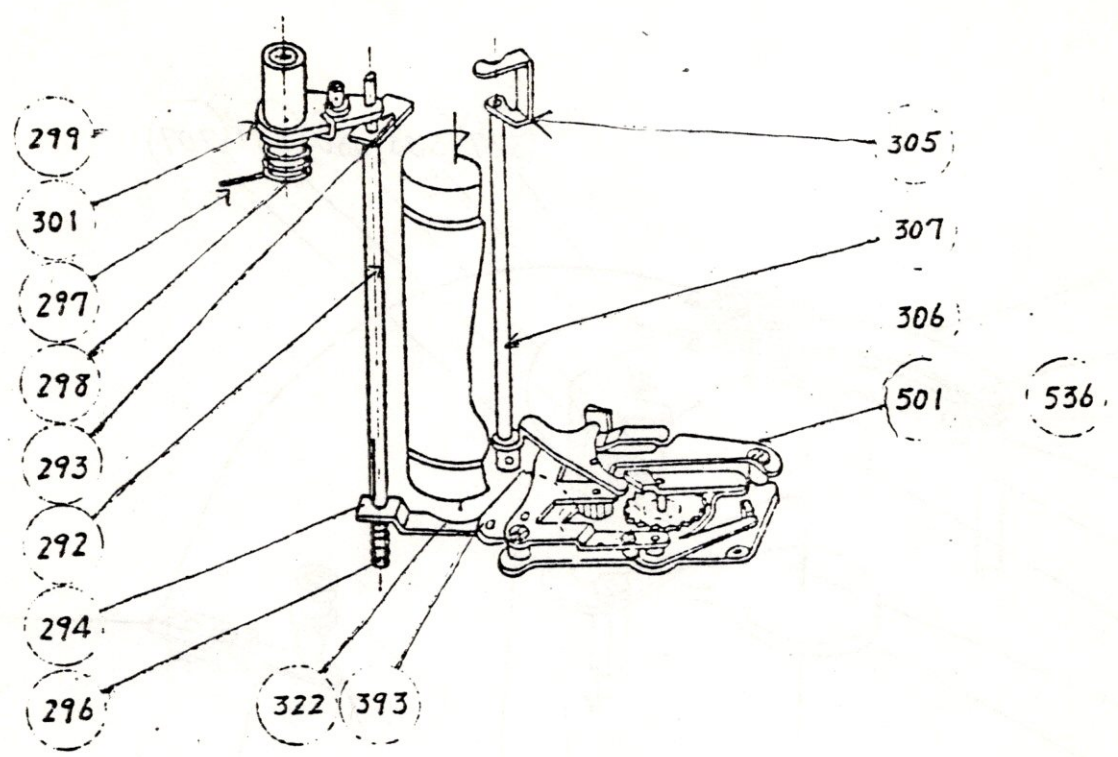

Fig - 14

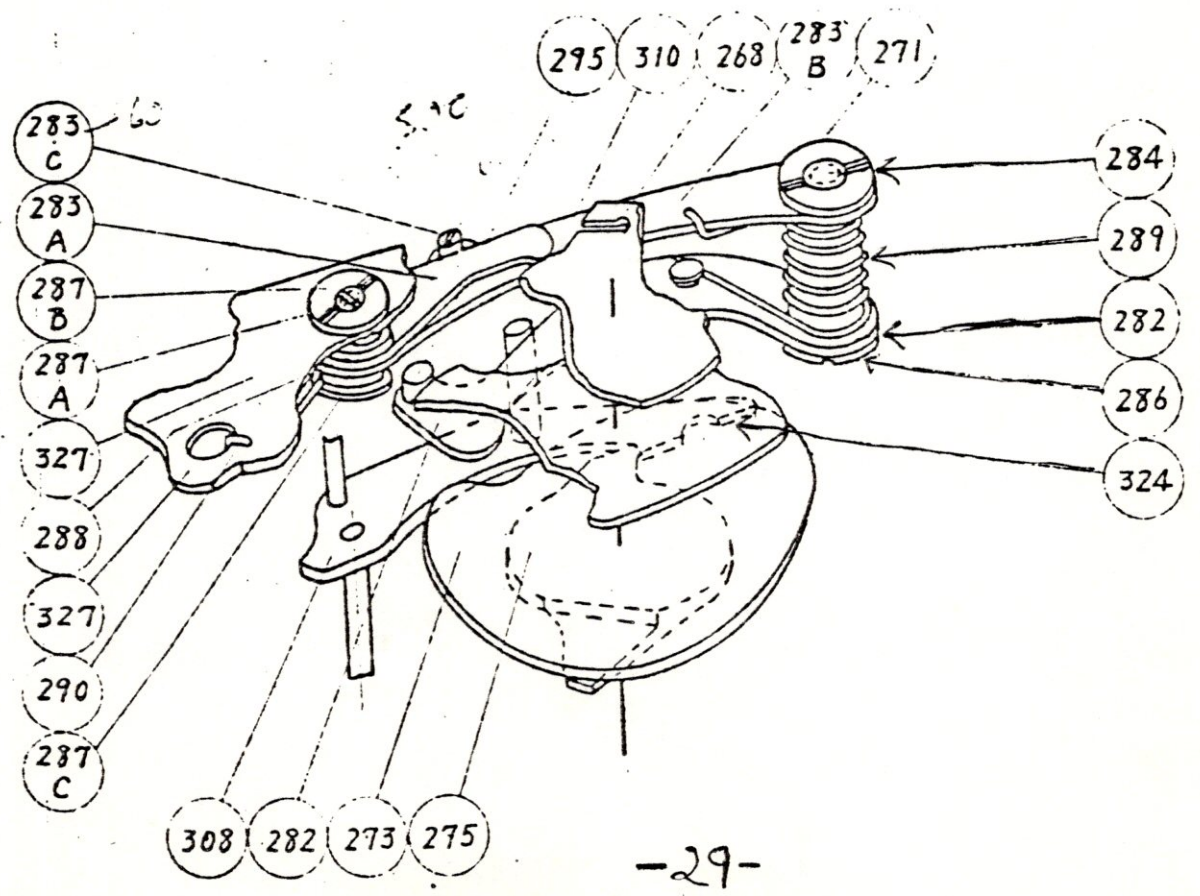

Fig. - 15

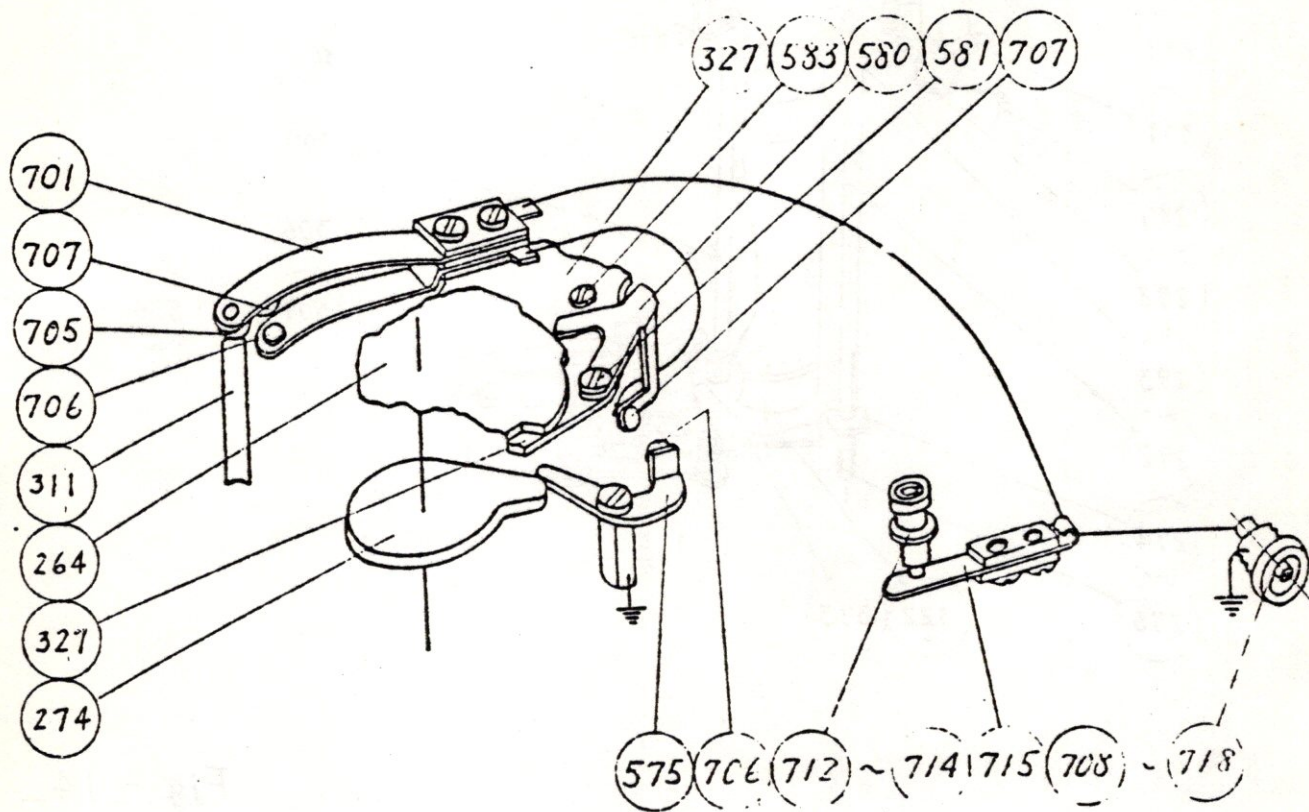

Fig - 16

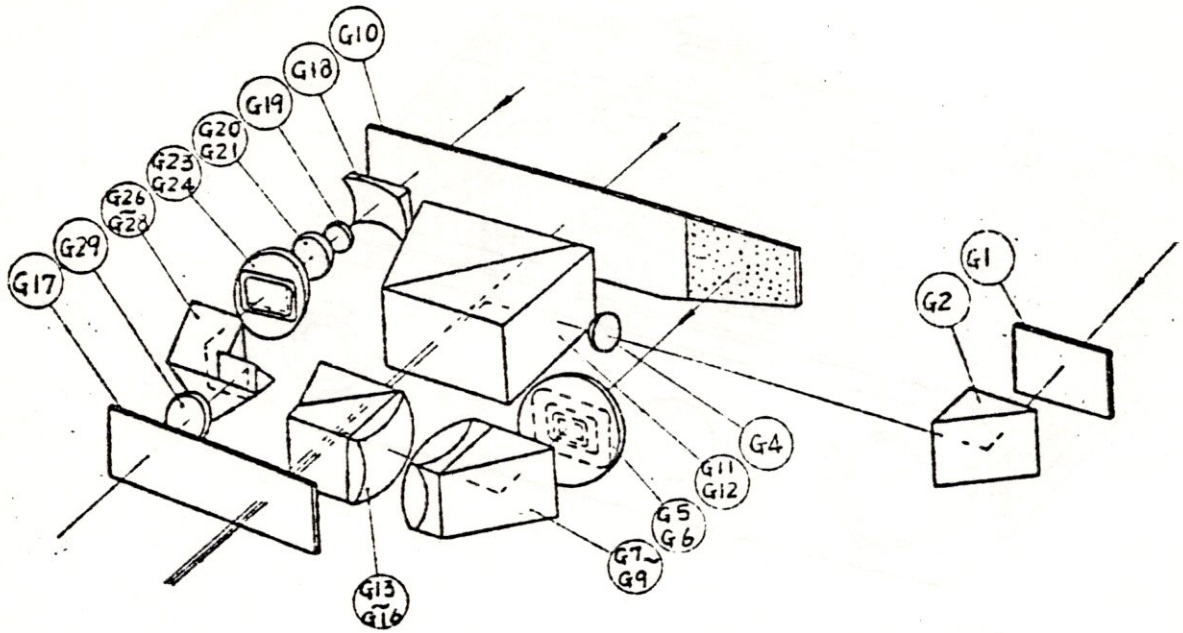

Fig - 17

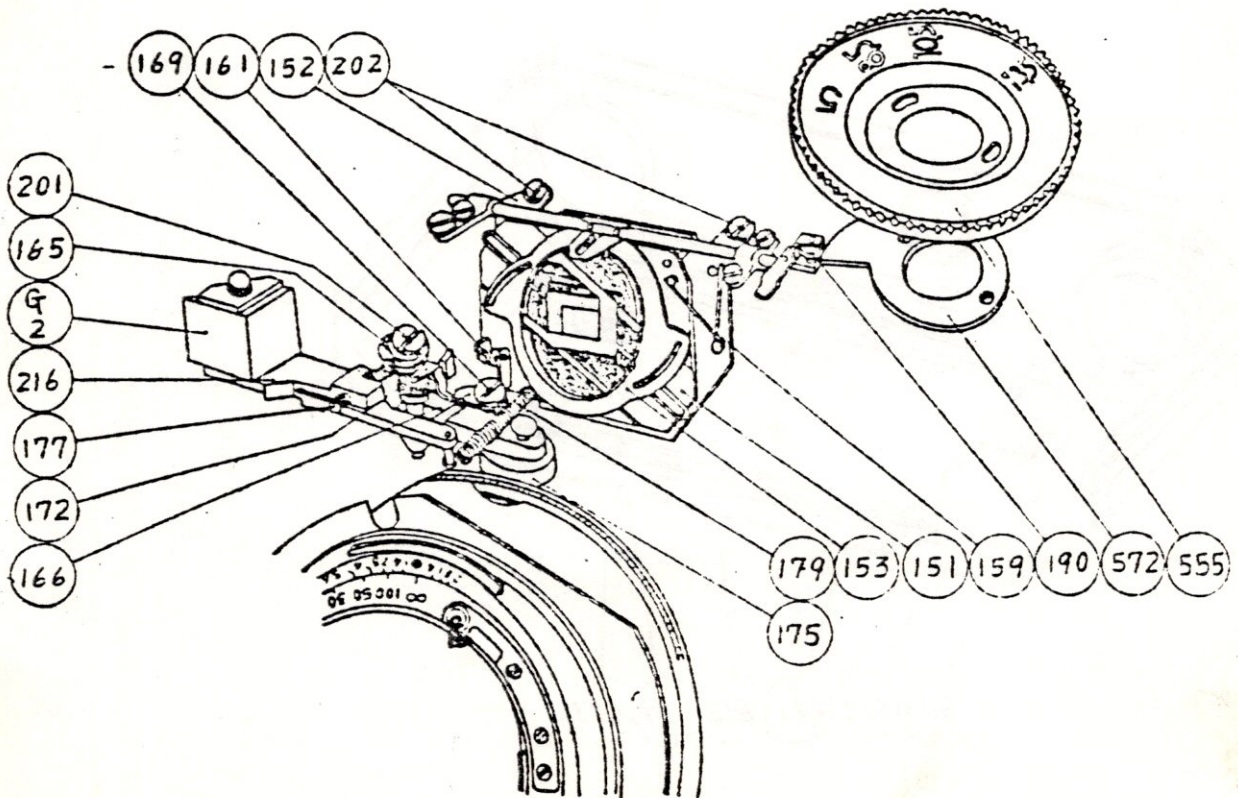

Fig - 18

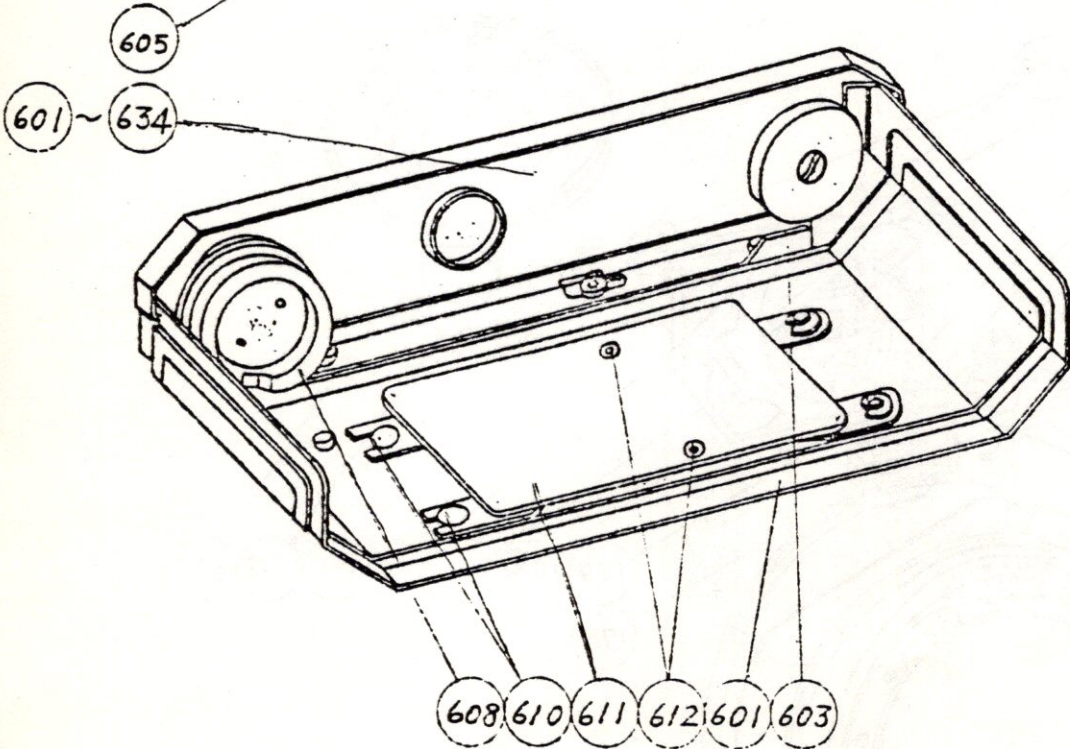
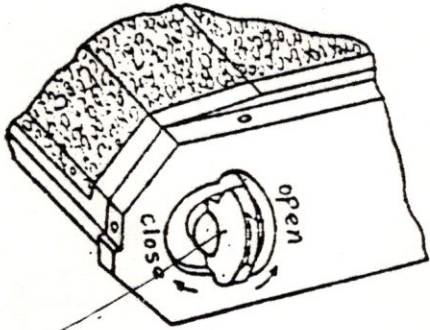
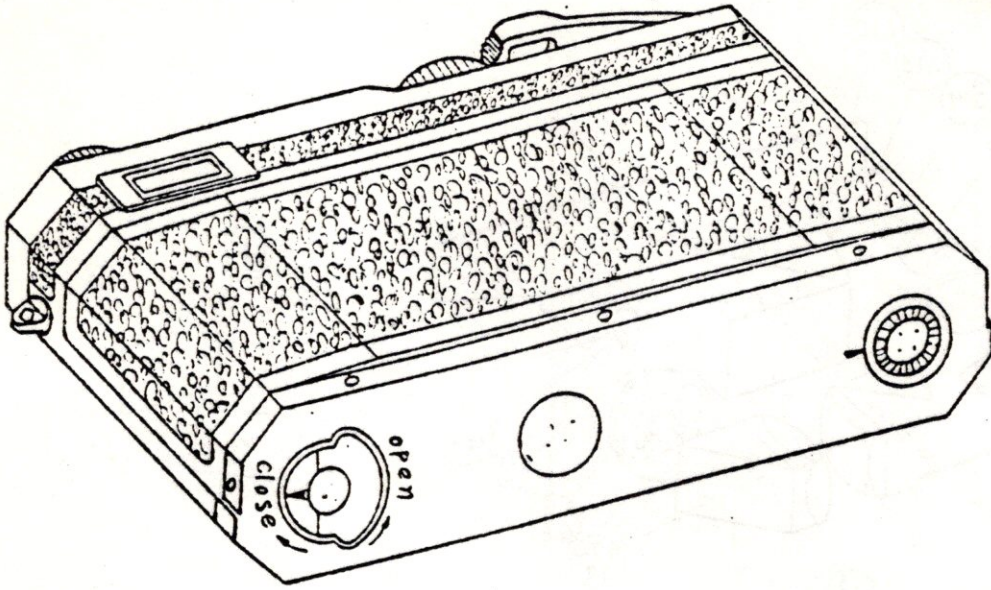

Fig-19

