

 **Polaroid** 600 Series Land Camera

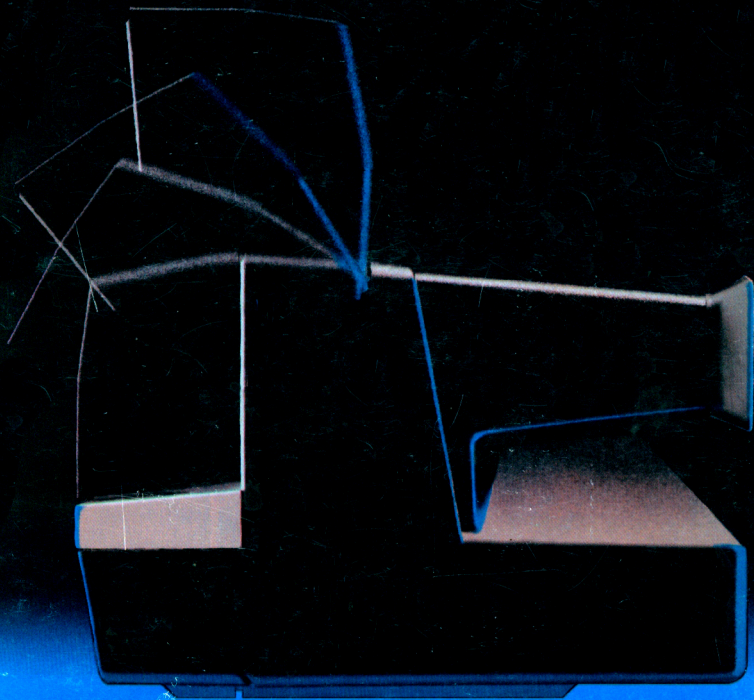

This product is listed by Underwriters' Laboratories, Inc. (UL). As a condition of listing, UL requires that basic safety information be provided.

IMPORTANT SAFEGUARDS

AS WITH ANY BATTERY-OPERATED EQUIPMENT, OBSERVE THESE BASIC SAFETY PRECAUTIONS:

1. FOLLOW ALL OF THESE INSTRUCTIONS.
2. DO NOT USE THE ELECTRONIC FLASH UNIT IF IT HAS BEEN DROPPED OR DAMAGED, UNTIL IT HAS BEEN EXAMINED AT AN AUTHORIZED POLAROID SERVICE CENTER.
3. TO AVOID ELECTRICAL SHOCK HAZARDS, DO NOT DISASSEMBLE THE FLASH UNIT. SERVICE OR REPAIR WORK MUST BE DONE ONLY BY AN AUTHORIZED POLAROID SERVICE CENTER. INCORRECT REASSEMBLY CAN CAUSE AN ELECTRICAL SHOCK WHEN THE FLASH UNIT IS USED AGAIN. DO NOT IMMERSE THE FLASH UNIT IN WATER OR OTHER FLUIDS.

PLEASE KEEP
THESE
INSTRUCTIONS

Contents

- 2** Important safeguards
- 4** The film
- 4** Call us, free

To use the camera

- 5** Raise the electronic flash
- 6** Load the film
- 7** Position your subject
- 8** Hold the camera
- 9** Take the picture

The camera system

- 10** The electronic flash and other parts of the camera

Great pictures in any light— outdoors and indoors

- 12** Use the electronic flash for every picture—outdoors and indoors

Special situations and troubleshooting

- 16** Trouble-free picture-taking
- 17** Taking a picture through glass
- 17** Lighten/darken control

Customer information

- 18** Full one-year warranty
(For non-special edition cameras)
- 18** Full five-year warranty
(For special edition cameras)
- 19** Copies and enlargements
- 19** Camera repair

The film

Use only Polaroid **600 color film**. Other Polaroid films will not fit into or work with this camera.

Each film pack provides 10 color pictures and contains a high-energy battery that powers both the camera and the electronic flash.

A film expiration date appears on the bottom of every film box. Check this date before buying film to be sure the film is fresh.

Call us, free

Whenever you have a question about your camera or pictures, call us toll free...

800-225-1384

from anywhere in the U.S.A. Our Customer Service representatives can be reached every weekday from 8 a.m. to 5 p.m., Eastern Time. In Canada, call toll free – 800-268-6970.

To use the camera:

1. Raise the electronic flash

Grip the sides of the flash unit.

Swing the flash unit up to snap it in place.

The flash will fully charge, **automatically**, in about **3 seconds** every time you:

- Load film into the camera when the flash unit is raised.
- Raise the flash unit when there is film already in the camera.

- Take a picture.
- Or, when you simply touch the shutter button.

The flash is designed to be used for **every** picture – outdoors and indoors.

When you are not using the camera, lower the flash unit. It will protect the lens and lock the shutter button.

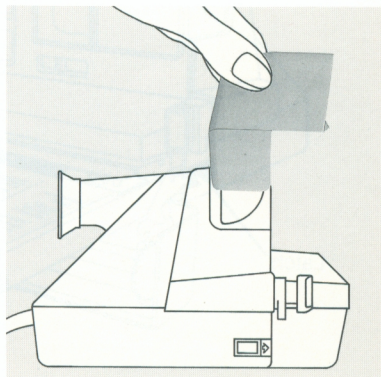
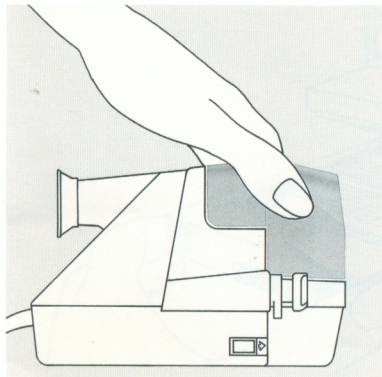

2. Load the film

Use **only** Polaroid 600 color film.

Push the latch **forward**.

Hold the film pack by its edges **only**, as shown, and slide it all the way into the camera. Close the film door. As soon as it is closed:

- The camera will eject the film cover.

- The red light on the back of the flash unit will come on to show the flash is charging. **In about 3 seconds**, the green light will come on to show the flash is ready to fire.

To remove an empty film pack, pull the colored tab on the film pack.

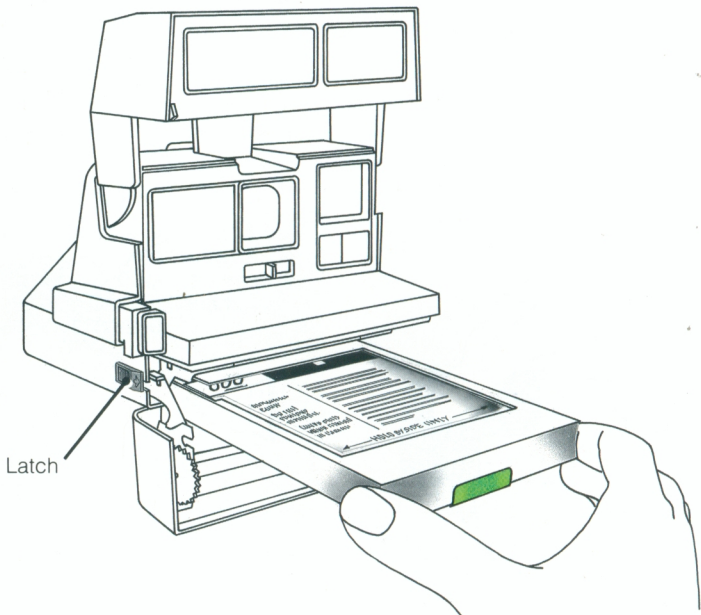

3. Position your subject

Indoors

For best results indoors, your subject should be from **4 to 10 feet (1.2 to 3m)** away and **near a light colored background.**

Outdoors

Your subject should be **at least 4 feet (1.2m) away.**

4. Hold the camera

Grip the camera in the palm of your left hand.

Place your right thumb on the thumb-rest, your index finger on the shutter button, and curl your other fingers into your palm.

Or, if it is more comfortable, place the fingers of your left hand over the top of the viewfinder and your thumb under the camera—holding your right hand as described above.

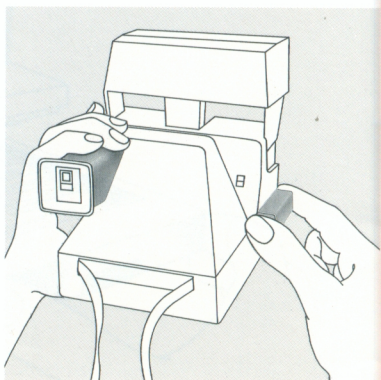
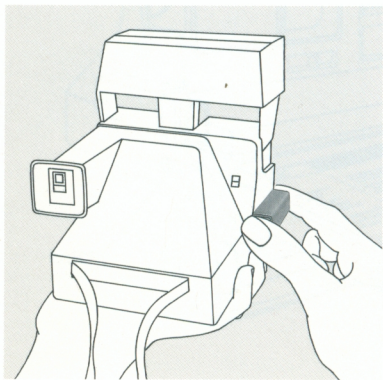

5. Take the picture

When you see the green light, press the shutter button all the way to take a picture.

After you have taken a picture, the flash will recharge and the green light will come on again in about 3 seconds.

When you want to take a picture and the green light has gone off, lightly touch the shutter button and **release it as soon as the red light comes on**. Then take the picture when you see the green light.

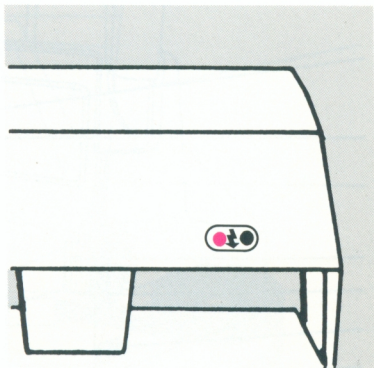
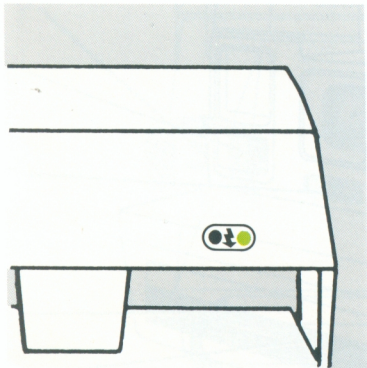

The camera system

1. Built-in electronic flash (from 1/3000 to 1/20,000 of a second).
2. Fixed focus, f/14.6, 106mm lens.
3. Automatic variable speed/aperture shutter system (speeds range from 1/200 to 1/3 of a second; apertures from f/14.6 to f/45).
4. Shutter button (press to take a picture).
5. Flash override button (use to take a picture through glass – see page 17).
6. Film door latch.
7. Film door.
8. Film shade (shields each picture from light as it exits the camera; it rolls out with the picture, then snaps back).

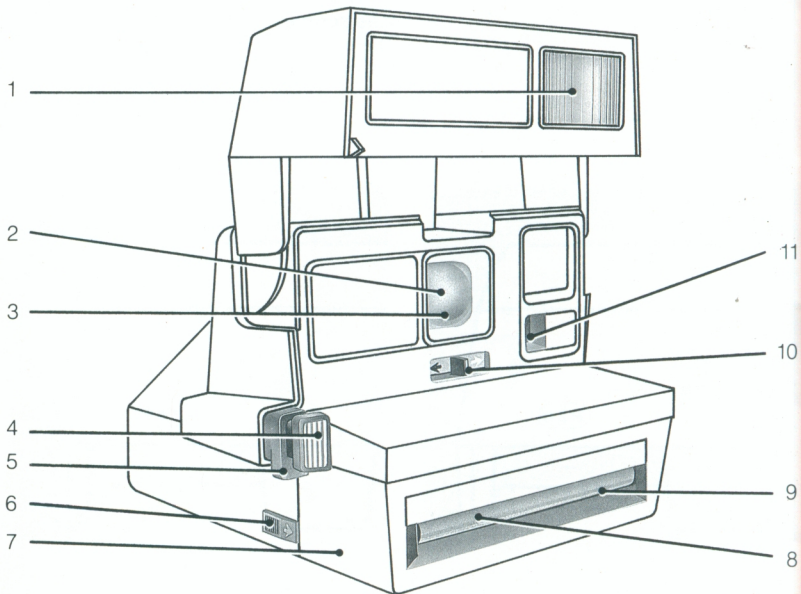

9. Film exit slot.
10. Lighten/darken control (see page 17).
11. Photocell (silicon photo-diode – measures light from the scene, outdoors and indoors).
12. Viewfinder.
13. Adjustable neckstrap.
14. Thumbrest.
15. Picture counter (indicates how many pictures remain).
16. Red light (means the flash is charging).
17. Green light (means the flash is ready to fire and you can take a picture).

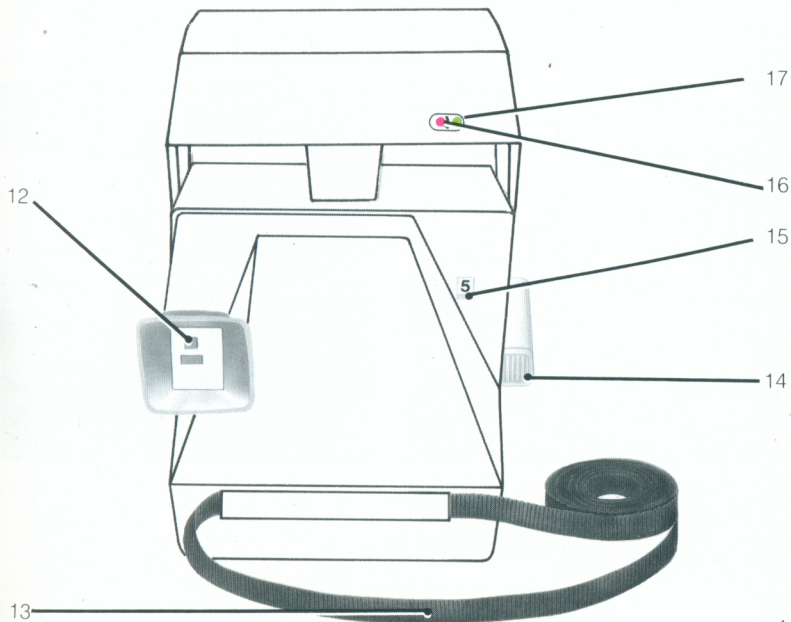

Great pictures in any light— outdoors and indoors

The human eye adjusts to light differently than the camera's eye, which makes it difficult to judge how light from the scene will affect your picture.

Everyone who takes pictures has had the experience of looking at a subject or scene, photographing it, and being disappointed with the picture because it looks different than what he or she saw in the viewfinder.

So Polaroid designed a new photographic system that gives you the beautiful picture you expect to see. By blending light from the scene with just enough flash, the system creates a new photographic light that more accurately reproduces, on film, what appeared in the viewfinder.

Here are some examples of what this system can do when you use the electronic flash for **every picture**—outdoors and indoors.

Use the electronic flash for every picture – outdoors and indoors

Soft window light creates a wonderful atmosphere for picture-taking, but it can be uneven.



Your electronic flash will provide the balanced light needed to create a flattering portrait.



Use the electronic flash for every picture – outdoors and indoors

Shade will spare your subject from having to squint in the harsh sunlight, but it does not always provide enough light for a well-exposed picture.

Your camera's built-in electronic flash will automatically supply the additional light needed to produce a pleasing photograph.



In this outdoor scene, photographed without electronic flash, bright sunlight has created harsh facial shadows. When taking a picture in this lighting situation, your eye adjusts to these shadows, showing you, in the viewfinder, facial features that will not be recorded on film.



Your new photographic system will blend sunlight with just the right amount of flash to soften shadows and reveal the facial details you expect to see in the picture.

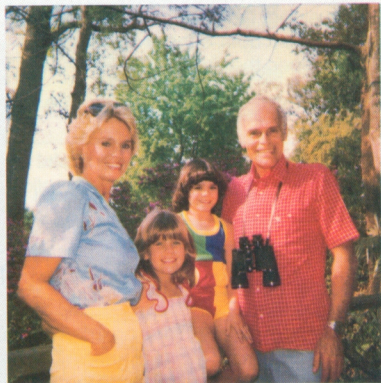

Trouble-free picture-taking

Hold the developing picture by its wide white border.

While it is developing, keep the picture out of direct sunlight.

When the temperature is below 55°F (13°C), keep the camera and film warm. Immediately place the developing picture in a warm pocket for at least a minute.

Keep the developer rollers clean.

Dirty rollers can cause a repeated spot or bar pattern to appear in the picture.

The developer rollers are located inside the film door. If there is film in the camera, open the door in dim light.

Clean the rollers with a damp, lint-free cloth.

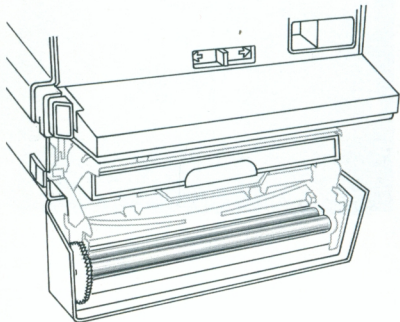

What to look for if the camera does not eject film:

Check the picture counter. When the film pack is empty, the flash will charge but you cannot take a picture.

When the red light on the back of the flash unit is on, the flash is charging and you cannot take a picture until the green light comes on.



Taking a picture through glass

Photographing a **daylight** scene through glass is a special situation which requires that you stop the electronic flash from firing to avoid a flash reflection. Take the picture by pressing only the flash override button, as shown.

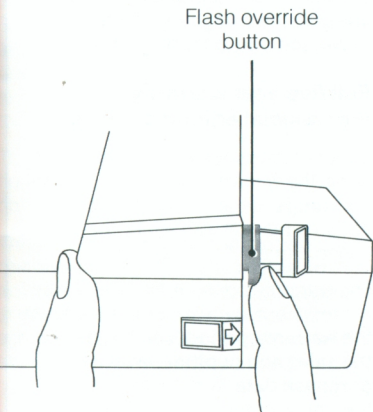

Lighten/darken control

Use this control **only** when you want to reshoot a picture to make it lighter or darker.

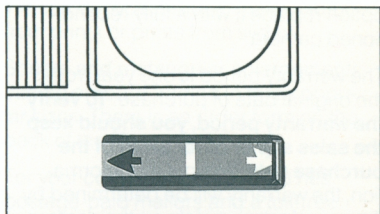

To take a lighter picture, slide the control past the white arrow.

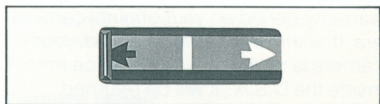

To take a darker picture, slide the control past the black arrow.

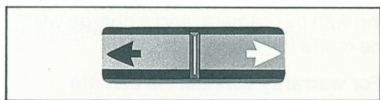

Return the control to center when you have finished reshooting. A white double arrow appears in the bottom of the viewfinder as a reminder that the control is not in center position.

Full one-year warranty (For non-special edition cameras)

If your camera proves to be defective within the warranty period, we will, without charge, either repair it or at our option replace it with a fully reconditioned camera.

The warranty period is one year from the original date of purchase. **To verify the warranty period, you should keep the sales slip or other proof of the purchase date.** Without this information, the warranty will be determined by the manufacturing date on the camera.

The repair or replacement of your camera is guaranteed for the remaining warranty period on your original camera. If, within the warranty period, your camera is mailed to us for service from inside the U.S.A., it will be returned with a postal refund.

The warranty does not cover damage caused by accident, misuse or tampering with the camera, and a charge will be made for such repairs.

For warranty service, the camera must be returned to and repaired by a Polaroid Service Center or Authorized Service Center in the United States or Canada. You can return the camera through your Polaroid camera dealer. If that is not convenient, call Customer Service toll free at 800-225-1384 from anywhere in the U.S.A. We can be

reached Monday through Friday, 8 a.m. to 5 p.m., Eastern Time. In Canada call toll free 800-268-6970.

This warranty gives you specific legal rights and you may also have other rights which vary from state to state.

This warranty excludes all consequential damages. Some states do not allow the exclusion or limitation of accidental or consequential damages, so the foregoing limitation or exclusion may not apply to you.

Full five-year warranty (For special edition cameras)

If your camera proves to be defective within the warranty period, we will, without charge, either repair it or at our option replace it with a fully reconditioned camera.

The warranty period is five years from the original date of purchase. **To verify the warranty period, you should keep the sales slip or other proof of the purchase date.** Without this information, the warranty will be determined by the manufacturing date on the camera.

The repair or replacement of your camera is guaranteed for the remaining warranty period on your original camera. If, within the warranty period, your camera is mailed to us for service from inside the U.S.A., it will be returned with a postal refund.

The warranty does not cover damage caused by accident, misuse or tampering with the camera, and a charge will be made for such repairs.

For warranty service, the camera must be returned to and repaired by a Polaroid Service Center or Authorized Service Center in the United States or Canada. You can return the camera through your Polaroid camera dealer. If that is not convenient, call Customer Service toll free at 800-225-1384 from anywhere in the U.S.A. We can be reached Monday through Friday, 8 a.m. to 5 p.m., Eastern Time. In Canada call toll free 800-268-6970.

This warranty gives you specific legal rights and you may also have other rights which vary from state to state.

This warranty excludes all consequential damages. Some states do not allow the exclusion or limitation of accidental or consequential damages, so the foregoing limitation or exclusion may not apply to you.

Copies and enlargements

Send Polaroid any photograph or 35mm slide – color or black and white, instant or conventional. We can copy photographs and make enlargements. We can duplicate slides, make slides from prints or prints from slides.

Square and rectangular enlargements can be ordered framed in three popular sizes. There is an order form on the back of the film cover.*

For your convenience, Polaroid has postage-paid mailers and a toll-free number. If you have any questions or special requests call (800) 421-1030. In California, call collect (213) 643-8093.

*When you load film into the camera, it automatically ejects the film cover.

Camera repair

If you think your camera needs repair, please call Customer Service (see page 4). We may be able to save you the trouble of returning the camera.

P2526 2/85 765630/C04
"Polaroid"® Printed in U.S.A. CS 5-108