



HAPPY NEW YEAR
HAPPY NEW YEAR

The NIKON  Journal



By Robert Rotoloni

THE NIKON JOURNAL IS THE OFFICIAL PUBLICATION OF THE NIKON HISTORICAL SOCIETY AND IS PRODUCED BY RJR PUBLISHING, INC. FOR THE EDUCATION AND BENEFIT OF

ITS MEMBERS, AND IS PUBLISHED FOUR TIMES A YEAR. ADDRESS ALL CORRESPONDENCE TO:
ROBERT ROTOLONI, P.O. BOX 3213,
MUNSTER, INDIANA 46321.....USA.

CONTENTS

- PAGE ONE
EDITORIAL.....R. ROTOLONI
- PAGE TWO
BOXED--LIKE NEW....PART 5
BY R.ROTOLONI
- PAGE FIVE
NIKON VARIFRAME REVISITED
BY R.ROTOLONI
- PAGE TEN
EARLY JAPANESE ADS
BY TSUYOSHI KONNO
- PAGE TWELVE
CAMERA CASES/M THRU S4
BY GARY STONE
- PAGE FOURTEEN
NIKON RF BIBLIOGRAPHY
PART 4 BY CARL JOECKS
NEW MEMBERS.....
- PAGE FIFTEEN
LETTERS TO N.H.S.
ADDRESS CHANGES
- PAGE SIXTEEN
CLASSIFIEDS
BLACK IS BEAUTIFUL
NEXT ISSUE
- INSIDE REAR COVER
ODDS N ENDS....

SOCIETY MEMBERS

ROBERT ROTOLONI	SIMON CIVJAN, DDS.
DAVID WEILER	LLOYD MINARI, MD.
JOHN ANGLE	AKITO TAMLA
ROBERT HARRIS	MIKIO AWANO
SAM DECKER, MD.	ROBERT FAIRCHILD
RANDY REED	RAYMOND F. YOUNG
CARL JOECKS	WILLIAM JACKSON, MD.
STEPHEN GANDY	ALBERT KUBANIS
MEL WILNER, DDS.	GEORGE URY
MAURICE MAUNER	VIC GORECKI
RANDOL HOOPER, MD.	EDWARD BROSKEY
CHARLES PADDOCK	BEN DI GREGORIO
RICHARD SEYFARTH	KARL MANTYLA
PETER DECHERT	JOHN SCHRADER
HAYATO UYAMA	BOB THOMPSON
JERRY ROLD	JEREMY ROWE
BURTON RUBIN, DDS.	TAKAYUKI KAWAI
HARRY SOLETSKY	SHIGERU KAJII
ROBERT HABER	R.E. (TED) CAIS
TIMOTHY LEEDY	ROY VOSE
GARY STONE	JOHN HANSEN, JR.
TAD SATO	J.L. HUTCHINSON
WILLIAM ADAMS	F.W. MATTHEWS
JAMES MOORE	P.H. VAN HASBROECK
ALAN JOHANSON	JAMES MARTIN
TSUYOSHI KONNO	OLIVER J. REDDAWAY
SHICHIROE ABE	TANEO IMAI
KATSUMI WATANABE	W.S. EMERY
WILLIAM KRAUS	TONY HURST
PAUL COMON	

THOSE NAMED ABOVE ARE THE MEMBERS OF THE NIKON HISTORICAL SOCIETY AS OF THE PUBLICATION OF THE SIXTH ISSUE OF THE "NHS" JOURNAL.

MEMBER CONTRIBUTIONS :

ANY CONTRIBUTIONS BY MEMBERS OF MANUSCRIPTS AND/OR PHOTOGRAPHS CONCERNING THE NIKON RANGEFINDER SERIES ARE APPRECIATED AND EVERY ATTEMPT WILL BE MADE TO MAKE USE OF ALL SUBMITTALS AS SPACE ALLOWS. PLEASE TYPE ALL MANUSCRIPTS AND MAKE ALL B/W

PHOTOS AT LEAST 3 BY 5 GLOSSY. A SEAMLESS BACKGROUND IS PREFERRED AND MAKE ALL PHOTOS HIGH CONTRAST. YOU WILL BE GIVEN A BY-LINE UNLESS ANONYMITY IS REQUESTED AND ENCLOSE AN "SASE" IF RETURN OF MATERIAL IS DESIRED.....THANK YOU.

EDITORIAL

EVEN THOUGH YOU WILL BE RECEIVING THIS ISSUE AFTER THE FIRST I WOULD LIKE TO WISH YOU AND YOURS A SAFE AND HAPPY HOLIDAY SEASON AND A PROSPEROUS NEW YEAR. MAY 1985 BRING YOU GOOD HEALTH AND MANY NIKONS.

I HAVE HELD OFF WRITING THIS EDITORIAL UNTIL DECEMBER 20TH. IN AN EFFORT TO COMPILE AS ACCURATE A MEMBERSHIP LIST AS IS POSSIBLE. I AM STILL WAITING ANSWERS TO LETTERS I HAVE SENT OUT TO SOME PEOPLE REQUESTING INFORMATION ABOUT THE SOCIETY. SO THE LIST MAY HAVE ADDITIONS NEXT ISSUE. AT THIS TIME I HAVE 60 CONFIRMED MEMBERS. YOU WILL NOTICE A FEW NAMES MISSING FOR WE DID LOSE SOME. ONE EVEN CALLED ME UP TO TELL ME HE WAS NOT REJOINING BECAUSE HE HAD LOST INTEREST IN COLLECTING. YOU WILL ALSO NOTICE SOME NEW NAMES ON OUR LIST. TWO ARE FROM ENGLAND AND ONE EACH FROM JAPAN AND IRELAND, SO IT LOOKS LIKE OUR SOCIETY IS BECOMING MORE INTERNATIONAL EVERYDAY. AT THIS TIME I WOULD LIKE TO WELCOME THEM:

PAUL-HENRY VAN HASBROECK
JAMES MARTIN
OLIVER J. REDDAWAY
TANEO IMAI
W.S. EMERY
TONY HURST

YOU WILL FIND THEIR ADDRESSES ON PAGE 14. WELCOME GENTLEMEN.

THIS ISSUE HAS SOME OF THE OLD AND SOME OF THE NEW. THE RUNNING FEATURE "BOXED----LIKE NEW" IS BACK WITH ANOTHER ARRAY OF INTERESTING NIKON RANGEFINDER EQUIPMENT STILL BOXED AND BEAUTIFUL. WHAT I LIKE IS THAT ONLY ONE PHOTO IS MINE..... KEEP THOSE CONTRIBUTIONS COMING FOLKS.

THE MAIN ARTICLE THIS ISSUE IS A FOLLOW-UP TO ITS COUNTERPART IN THE PREMIER ISSUE OF THE JOURNAL. IT IS MORE PHOTOS AND INFORMATION ABOUT THE NIKON VARIFRAME FINDER. I WROTE THAT FIRST ARTICLE NEARLY 16 MONTHS AGO. SINCE COLLECTING IS AN EVER CHANGING AND DYNAMIC FIELD, NEW INFORMATION COMES MY WAY ALMOST

DAILY AND I FELT ENOUGH NEW MATERIAL WAS NOW AVAILABLE TO WARRANT AN UPDATED ARTICLE. I AM NOW ABLE TO ILLUSTRATE FOUR ADDITIONAL TYPES PLUS THE MAJOR ACCESSORY MADE FOR IT.

ON PAGE 14 IS THE FOURTH PART OF THE NIKON BIBLIOGRAPHY BY CARL JOECKS AND MORE BLACK BODY NUMBERS APPEAR ON PAGE 16. I HAVE RECENTLY LEARNED OF TWO "REPLICA" BLACK NIKONS. I WILL TRY TO PUBLISH THEIR NUMBERS IN THE NEXT ISSUE AND KEEP YOU INFORMED OF ANY FURTHER DEVELOPMENTS.

THE "ODDS N ENDS" FEATURE THIS TIME IS A UNIQUE CUT-A-WAY OF A NIKON ZOOM LENS I THINK YOU WILL FIND INTERESTING.

NEW THIS ISSUE IS AN ARTICLE ON VARIATIONS SEEN IN THE EVER-READY CASES MADE BY NIKON AND WAS SUBMITTED BY GARY STONE. I HOPE TO EXPAND ON IT IN THE FUTURE. ON PAGE 10 AND 11, PLUS THE REAR COVER, YOU WILL FIND REPRODUCTIONS OF SOME VERY EARLY MAGAZINE ADS FOR THE NIKON RANGEFINDERS SUBMITTED BY MR. TSUYOSHI KONNO. WHAT IS INTERESTING IS THAT THESE ARE JAPANESE ADS THAT SHOW EARLY NIKON PROTOTYPE EQUIPMENT SIMILAR TO WHAT APPEARED IN THE LAST ISSUE OF THE JOURNAL. I AM SURE THE MEMBERSHIP WOULD LIKE TO SEE MORE ITEMS ALONG THIS LINE SO I AM RUNNING A CLASSIFIED AD REQUESTING MORE OF THE SAME. I HAVE SOME OF THE ADS THAT RAN IN THE AMERICAN MAGAZINES SUCH AS MODERN AND POPULAR PHOTOGRAPHY AND U.S. CAMERA. HOWEVER, I KNOW I AM MISSING SOME PLUS I HAVE NONE FROM ENGLAND, JAPAN AND EUROPE. ANYTHING WOULD BE APPRECIATED AND I WILL GIVE YOU A BY-LINE WITH YOUR CONTRIBUTION. HOPE TO HEAR FROM YOU.

AGAIN WELCOME TO THE NEW MEMBERS AND THOSE OF YOU WHO REJOINED AND A HAPPY NEW YEAR TO ALL OF YOU.

ROBERT ROTOLONI
EDITOR/PUBLISHER

BOXED LIKE NEW

Part V

BECAUSE OF A LACK OF SPACE I HAD TO ELIMINATE THE RUNNING FEATURE "BOXED--LIKE NEW" IN NHS-5. I PROMISED THEN THAT IT WOULD RETURN THIS ISSUE AND HERE IT IS, FOR BETTER OR WORSE. ACTUALLY I HAVE HAD A GREAT DEAL OF POSITIVE MAIL ON THIS FEATURE AND QUITE A FEW CONTRIBUTIONS OF MEMBERS LIKE NEW ITEMS IN THEIR ORIGINAL BOXES.

FIRST UP THIS TIME AROUND IS ANOTHER SHOT OF A BOXED 35MM. F2.5 NIKKOR. IN NHS-3 YOU SAW TWO DIFFERENT VERSIONS, BOTH VELVETEEN TYPE BOXES. THOSE TWO WERE AN EARLIER TYPE AND THE ONE THIS ISSUE IS OF LATER VINTAGE. IT IS THE COMMONLY SEEN GOLD STRIPED BOX WHICH SEEMS TO HAVE FIRST APPEARED DURING THE NIKON S2 ERA. THIS EXAMPLE IS NO. 265200 AND IS IN THE SECOND TO THE LAST TYPE OF BARREL. INCLUDED IS THE ORIGINAL WARRANTY CARD, CASE AND CAPS. THANKS TO MEMBER JOHN ANGLE FOR ALLOWING ME TO PHOTOGRAPH IT.

THE SECOND ITEM IS ANOTHER 35MM. NIKKOR, BUT THIS ONE IS THE F3.5 VERSION. THIS PHOTO WAS SENT TO ME BY MR. TSUYOSHI KONNO OF JAPAN AND SHOWS LENS NO. 434204 IN AN EARLY TYPE BLUE VELVETEEN BOX. THE LETTERING ON THIS, AND ALL OF THE OTHER VELVETEEN BOXES, IS GOLD AND PRESSED INTO THE MATERIAL. IT ACTUALLY IS VERY IMPRESSIVE ESPECIALLY WHEN THE BOX IS IN MINT CONDITION AS THIS ONE APPEARS TO BE. NOTE THAT IT HAS THE CAPS, CASE AND THE ORIGINAL DEPTH OF FIELD CHART WHICH IS DIFFERENT FROM OTHERS I OWN OR HAVE SEEN.

I HAVE WANTED TO INCLUDE A SHOT OF THE VERY IMPRESSIVE 180MM. F2.5 NIKKOR LENS IN THIS COLUMN FOR SOME TIME, BUT MY TWO BOXES ARE NOT VERY CLEAN. RECENTLY JOHN ANGLE ALLOWED ME TO PHOTOGRAPH YET ANOTHER ITEM FROM HIS COLLECTION. THIS IS LENS NO. 473631 WHICH IS A VERY EARLY EXAMPLE. IT IS NOT ONLY BOXED BUT ALSO NEW WITH THE SHADE, CAPS, WARRANTY CARD AND, WOULD YOU BELIEVE, THE ORIGINAL

PACK OF SILICA GEL MARKED WITH THE NIPPON KOGAKU LOGO.

OUR FOURTH SHOT IS ALSO FROM THE JOHN ANGLE COLLECTION (THIS IS GETTING TO BE A HABIT.....). NHS-2 HAD A SHOT OF THE 250MM. NIKKOR WHICH WAS A LATE LENS OF THE PRESET TYPE. THIS PHOTO SHOWS THIS SAME TYPE AGAIN (ON THE LEFT) BUT ALONGSIDE THE ORIGINAL TYPE BOX THAT HOUSED THE EARLY MANUAL LENS. NOTE THAT IT HAS A VERTICAL FORMAT WHILE THE LATER TYPE HELD THE LENS IN A HORIZONTAL POSITION. BOTH BOXES ARE BLUE PAPER ALTHOUGH THEIR FINISH IS SLIGHTLY DIFFERENT.

THE NEXT TWO SHOTS ARE OF THE CLOSE-UP ATTACHMENT MADE FOR THE NIKON SP/S3 CAMERAS. ALTHOUGH THESE UNITS ARE MARKED FOR THE SP ONLY THEY ALSO WORK ON THE S3 AND NO SEPARATE VERSION WAS EVER MADE FOR THE S3 MODEL. THE FIRST PHOTO IS OF TWO ATTACHMENTS, BOTH OF WHICH WERE MADE FOR THE NIKON SP/S3 WITH THE 50MM. F2.0 NIKKOR LENS. THESE TWO ARE FROM MY COLLECTION AND ARE INTERESTING FOR TWO REASONS. YOU MAY NOT BE ABLE TO READ SERIAL NUMBERS IN THIS REPRODUCTION BUT THEY ARE NUMBERS 30037 (LEFT) AND 30080 (RIGHT) WHICH ARE RATHER CLOSE TO EACH OTHER. HOWEVER, THEY CAME IN COMPLETELY DIFFERENT BOXES. THE LEFT ONE HAS A COLORFUL BOX THAT BOLDLY IDENTIFIES THE CONTENTS AS THE "NIKON CLOSE-UP ATTACHMENT" FOR ALL THE WORLD TO SEE. ON THE BASE OF THE BOX IS STAMPED "FOR SP AND 50MM. F2.0". I HAVE AN IDENTICAL BOX FOR THE S2 WITH THE F2 THAT DIFFERS ONLY BY THE STAMPED INFO ON THE BOTTOM. THE ONE ON THE RIGHT, HOWEVER, IS THE TOTALLY BLANK GREY BOX WHOSE ONLY IDENTIFICATION IS THE STAMP ON THE BOTTOM, AND THATS IT....

FROM THE TAD SATO COLLECTION IS A SHOT OF HIS CLOSE-UP FOR THE SP/S3 BUT FOR THE 50MM F1.4 NIKKOR. NOTE THAT IT CAME IN THE SAME BOX AS THE LEFT ONE IN THE PHOTO ABOVE. THE SAME BOX WAS USED BUT STAMPED DIFFERENTLY.

THIS IS 35MM. F2.5 NIKKOR
 NO. 265200 WITH ITS GOLD
 STRIPED BOX, CAPS AND
 CASE. NOTE ALSO THE
 ORIGINAL WARRANTY CARD.
 JOHN ANGLE.



HERE IS 35MM. F3.5 NIKKOR
 NO. 434204 WITH ITS BLUE
 VELVETEEN BOX, CAPS AND
 CASE. ALSO PRESENT IS
 THE ORIGINAL DEPTH OF
 FIELD CHART.
 TSUYOSHI KONNO.

A NEW 180MM. F2.5 NIKKOR
 WITH ITS BLUE PAPER BOX.
 ALSO NOTE THE ORIGINAL
 WARRANTY CARD AND PACK
 OF SILICA GEL.
 JOHN ANGLE.





BOTH TYPES OF BOXES FOR THE 250MM. NIKKOR. BOTH ARE BLUE PAPER BOXES BUT HAVE TOTALLY DIFFERENT SHAPES.
JOHN ANGLE.



TWO CLOSE-UP ATTACHMENTS FOR THE NIKON SP/S3 AND THE 50MM. F2.0 NIKKOR. THEY ARE NO. 30037 AND NO. 30080 BUT NOTE THE TWO COMPLETELY DIFFERENT BOXES USED.
ROBERT ROTOLONI.



ANOTHER CLOSE-UP FOR THE NIKON SP/S3 IS THIS ONE FOR THE 50MM. F1.4 LENS. NOTE THAT IT IS IN THE SAME TYPE BOX AS THE 2.0 VERSION ABOVE.
TAD SATO.

THE NIKON VARIFRAME REVISITED

THE MAIN ARTICLE IN THE PREMIER ISSUE OF THE "JOURNAL" DEALT WITH THE NIKON VARIFRAME FINDER. IT CONSISTED OF INFORMATION, AND PHOTOGRAPHS, IN MY FILES AT THAT TIME. OVER A YEAR HAS PASSED AND, AS ALWAYS, MORE INFORMATION HAS COME MY WAY. TWO THINGS HAVE HAPPENED. I HAVE BEEN ABLE TO OBTAIN EXAMPLES OF THE TWO EARLIEST TYPES SO THEY CAN BE ILLUSTRATED, PLUS PHOTOGRAPHS OF TWO OTHERS MISSING FROM THAT FIRST ARTICLE. ADD TO THAT THE FACT THAT I NOW HAVE HANDLED AND PHOTOGRAPHED THAT ELUSIVE 28MM. ATTACHMENT AND A MORE COMPLETE STUDY OF THIS ACCESSORY IS EVIDENT. NOW TO THE DETAILS.

THE FIRST OBVIOUS DIFFERENCE IS THE TABLE OF VARIATIONS IN WHICH TWO ADDITIONAL TYPES ARE NOW LISTED. TYPE 3 NOW CONSISTS OF A FINDER WHOSE EXISTENCE I WAS NOT AWARE OF A YEAR AGO. IT IS EARLIER THAN THE FINDER THAT ORIGINALLY OCCUPIED THIS SLOT, WHICH I NOW CALL TYPE 3(B). THE NEW TYPE 3 IS A FINDER MADE FOR THE NIKON ONE THAT IS ENGRAVED 24X32 ON ITS SIDE (LIKE TYPE 1) AND STARTS AT NO.9011 WITH RECORDED EXAMPLES 90114 AND 90194 SEEN TO DATE. I DO NOT HAVE A PHOTO BUT IT LOOKS EXACTLY LIKE TYPE 3(B) EXCEPT FOR THE 24X32 ENGRAVING.

THE SECOND ADDITION IS AT THE END OF THE TABLE AND IS TYPE TEN. IT IS EXACTLY LIKE TYPE NINE EXCEPT THAT IT IS FOR THE LEICA TYPE CAMERAS AND, THEREFORE, HAS CALIBRATIONS FOR 73MM AND 90MM. LENSES. I HAD YET TO RECORD SUCH A FINDER WHEN I WROTE THE FIRST ARTICLE BUT ITS EXISTENCE IS LOGICAL AND FOLLOWS THE PREVIOUS PRACTICE OF MAKING A LEICA-TYPE VERSION OF EACH VARIFRAME FINDER.

YOU WILL ALSO NOTE THAT I HAVE ALTERED THE POSSIBLE BEGINNING SERIAL NUMBERS TO REFLECT NIKONS TENDENCY TO USE A THREE DIGIT PREFIX WHICH WOULD MAKE THE FIRST ITEM PRODUCED NO. XXX1. THIS IS ESPECIALLY COMMON IN THE EARLY YEARS AND IS

BROUGHT OUT BY THE EXISTENCE OF SUCH FINDERS AS 70522, 70527, 71224, 71250, 90114, 90194 AND 90233, ALL OF WHICH ARE VERY EARLY MIOJ FINDERS.

THE MOST SIGNIFICANT FINDERS ARE THOSE FOR THE NIKON ONE. TWO TYPES EXIST (SEE ONE AND THREE) THAT DIFFER MARKEDLY. TYPE ONE WAS KNOWN TO ME BUT RECENTLY NO. 70522 CAME MY WAY AND I HAVE INCLUDED NINE PHOTOS TO ILLUSTRATE HOW DIFFERENT IT IS. NOTE THAT IT, AND TYPE TWO, SHARE A MOUNTING SHOE UNIQUE TO THESE EARLY FINDERS. ALSO NOTE THAT TYPE ONE IS A DULL CHROME AND TYPE TWO BRIGHT. LASTLY IS THE MARKED DIFFERENCE IN THE NOSE PIECES. TYPE ONE IS DIFFERENT FROM ANY OTHER, INCLUDING TYPE THREE, WHICH IS ALSO FOR THE NIKON ONE. IT IS A ONE PIECE ITEM LACKING THE SCREW OFF COVERING RING SEEN ON ALL OTHER TYPES UP TO THE LATEST. ALSO THIS NOSE PIECE SCREWS OFF EASILY AND IS NOT LOCKED ON LIKE ALL SUCCEEDING TYPES. AN INTERESTING POINT IS THAT THE WORD "NIKON" IS NOT PRESENT NEAR THE EYEPiece BUT IS ON TYPE TWO WHICH IS FOR THE LEICA????

AT THE TOP OF PAGE NINE IS A VARIATION OF TYPE 3(B) WHICH HAS THE "M" ABOVE THE SERIAL NUMBER INSTEAD OF PRECEEDING IT. I HAVE SEEN YET ANOTHER LIKE IT EXCEPT THAT THE "M" IS WITHIN QUOTATION MARKS.

ALSO ON PAGE NINE ARE FOUR PHOTOGRAPHS OF THE 28MM. ATTACHMENT MADE FOR THE LATER BLACK VARIFRAMES. A DIFFICULT ITEM TO FIND TODAY, IT MAY ALSO EXIST IN CHROME SINCE THREADS ARE PRESENT ON LATER CHROME FINDERS, BUT I HAVE YET TO HEAR OF ONE. AN INTERESTING ASPECT OF THIS ACCESSORY IS THE SMALL CHROME REMOVABLE RING SHOWN IN TWO OF THE PHOTOS. WITH THE RING ATTACHED THE 28MM. OBJECTIVE WILL NOT THREAD ONTO ANY NIKON VARIFRAME INCLUDING THE ONES FOR THE LEICA TYPE CAMERAS....?????? WHAT IS IT FOR????? COULD IT BE FOR LEICA MADE FINDERS???????

ROBERT ROTOLONI

VARIFRAME FINDER VARIATIONS

TYPE 1
HEAVY CHROME ON BRASS CONSTRUCTION-DULL FINISH-24X32 ON SIDE-EARLY STYLE SHOE AND PARALLAX LEVER-EYEPIECE AND CHAIN-MIOJ ON BASE OF SHOE-NO THREADS-FOR 35,50,85 AND 135MM.-NO "NIKON" AROUND EYEPIECE ON SAMPLE SEEN-ONE PIECE NOSE WITHOUT COVERING RING-NUMBERS BEGIN AT 7051-FOR NIKON MODEL ONE.

TYPE 2
SIMILAR TO TYPE ONE EXCEPT IT LACKS THE EYEPIECE AND CHAIN, IS FINISHED IN "BRIGHT" CHROME, HAS A TWO PIECE NOSE WITH THE COVERING RING AND CALIBRATIONS FOR 73,90 AND 105MM. LENSES-MIOJ-24X36 ON SIDE-SAME SHOE AND PARALLAX LEVER AS ABOVE-NO THREADS-SERIAL NUMBERS BEGIN AT 7121-MADE FOR LEICA TYPES.

TYPE 3
IS BRIGHT CHROME LIKE TYPE TWO-24X32 ON SIDE LIKE TYPE ONE-HAS NEW STYLE SHOE AND PARALLAX LEVER-HAS TWO PIECE NOSE WITH COVERING RING-HAS EYEPIECE AND CHAIN-MIOJ ON SHOE-NO THREADS-FOR 35,50,85 AND 135MM. LENSES-"NIKON" AROUND THE EYEPIECE-SERIAL NUMBERS BEGIN AT 9011-FOR NIKON MODEL ONE.

TYPE 3(B)
APPEARS IDENTICAL TO TYPE III-ONLY DIFFERENCE IS "M" THAT PRECEEDS SERIAL NUMBER AND NO FRAME SIZE ENGRAVING-THESE ARE FOR 24X34 BUT NOT MARKED-MIOJ-SERIAL NUMBERS BEGIN AT M9011?-MADE FOR NIKON M AND NOT ONE.

TYPE 4
LIKE TYPE III EXCEPT FOR LEICA TYPE CAMERAS-NO EYEPIECE AND CHAIN BUT "NIKON" AROUND THE EYEPIECE?????-24X36 ON SIDE-ALL ELSE SAME AS TYPE III AND MIOJ-NUMBERS BEGIN AT 9021.

TYPE 5
SIMILAR TO TYPE IV-24X36 ON THE SIDE-LACKS EYEPIECE AND CHAIN-SOME ARE MIOJ AND SOME HAVE THE THREADS-ADDITIONAL MARKINGS FOR 73, 90 AND 105MM.-NO "NIKON" ENGRAVING-SERIAL NUMBERS BEGIN AT 3131-FOR LEICA TYPES.

TYPE 6
SIMILAR TO TYPE FIVE-NO FRAME SIZE ENGRAVED-HAS EYEPIECE AND CHAIN-MARKED "MIOJ" UP TO AT LEAST 364288-HAS THREADS-FOR 35 50,85 AND 135MM. WITH AN INDEX MARK FOR 105MM. ON LATER ONES-"NIKON" AROUND EYEPIECE-SERIAL NUMBERS BEGIN AT 3641-MADE FOR EARLY NIKON S CAMERAS.

TYPE 7
CHROME REPLACED BY BLACK PAINT-NO FRAME SIZE ENGRAVED-PARALLAX LEVER ON MOUNTING SHOE AS ABOVE TYPES-LACKS EYEPIECE AND CHAIN-NONE ARE MIOJ-HAS THREADS-FOR 35,50,85,105 AND 135MM. LENSES-"NIKON" ON SIDE OF HOUSING-SERIAL NUMBERS BEGIN AT 5431-MADE FOR NIKON S2.

TYPE 8
IDENTICAL TO TYPE SEVEN EXCEPT IT HAS ADDITIONAL CALIBRATIONS FOR 73 AND 90MM.-SERIAL NUMBERS INTERMIXED WITH TYPE SEVEN WITH AN "L" SOMETIMES PRESENT-24X 36 ON SIDE OF HOUSING-MADE FOR LEICA TYPES.

TYPE 9
NEW STYLE BLACK HOUSING-TOPSIDE ACCESSORY SHOE ELIMINATED-DIAL FOR PARALLAX AT REAR AND NOT ON MOUNTING SHOE-HAS THREADS-FOR 35,50,85,105 AND 135MM. LENSES-SERIAL NUMBERS BEGIN AT 5611?-MADE FOR LATE NIKON S2.

TYPE 10
IDENTICAL TO TYPE NINE EXCEPT FOR LEICA TYPE CAMERAS-HAS THE MARKINGS FOR 73 AND 90MM.-THE LETTER "L" EITHER PRECEEDS OR IS ABOVE THE SERIAL NUMBER AND SOMETIMES PAINTED RED-NUMBERS ARE INTERMIXED WITH TYPE NINE

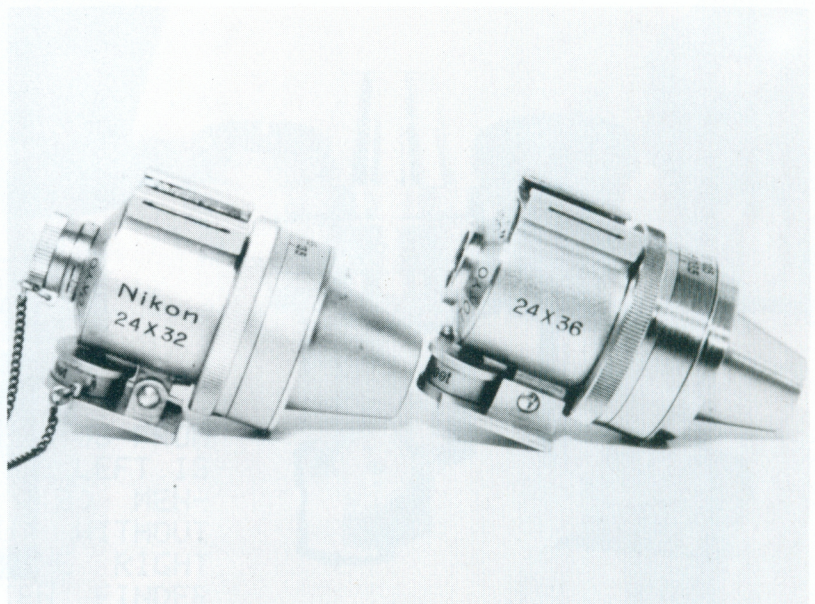
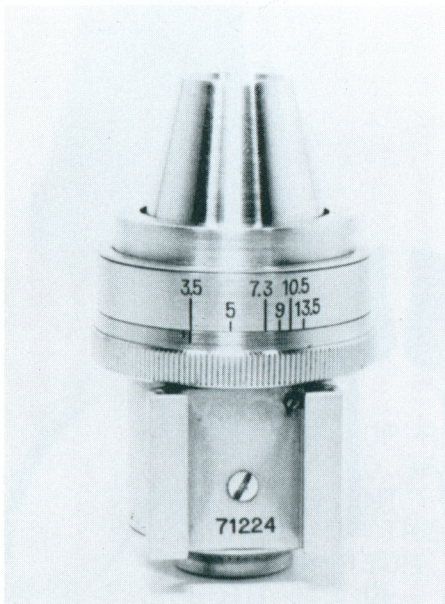

ON THIS PAGE ARE FINDERS NO. 70522 (FOR NIKON I) AND 71224 (FOR LEICAS), BOTH OF WHICH REPRESENT THE VERY FIRST BATCH OF THEIR RESPECTIVE TYPES. NOTE THE UNIQUE MOUNTING SHOE, TO DATE SEEN ONLY ON THESE TWO TYPES. BOTH ARE ENGRAVED WITH THEIR RESPECTIVE FRAME SIZES AND THE ONE FOR NIKON HAS THE EYEPIECE AND CHAIN. CURIOUSLY IT DOES NOT HAVE "NIKON" ENGRAVED AROUND THE EYEPIECE YET THE ONE FOR LEICA DOES??? ALSO NOTE THE DIFFERENT NOSEPIECE CONSTRUCTION AND CHROME FINISH, AS WELL AS THE "NIKON" ENGRAVING ABOVE THE 24X32 WHICH, MAY ACCOUNT FOR IT NOT BEING AROUND THE EYEPIECE.

ROBERT ROTOLONI.

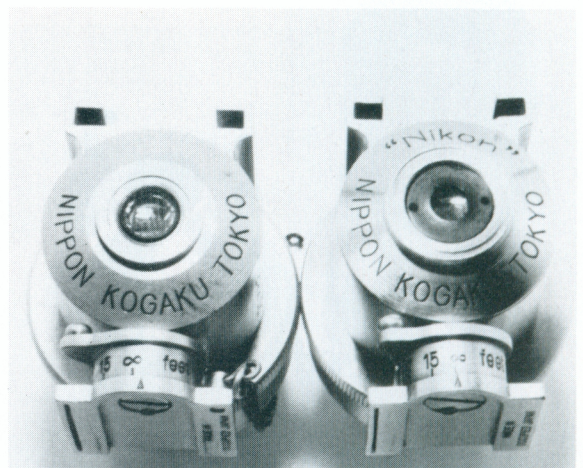

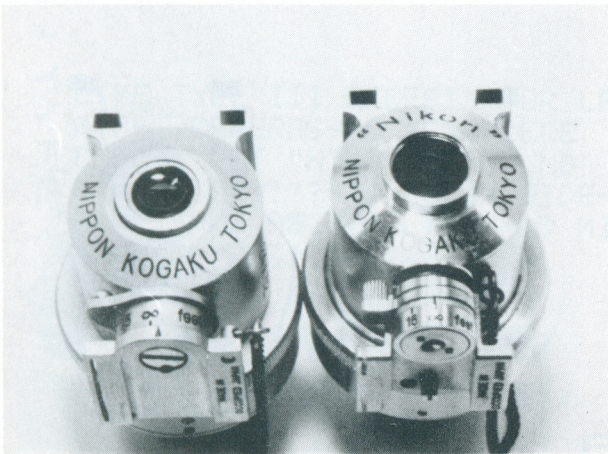
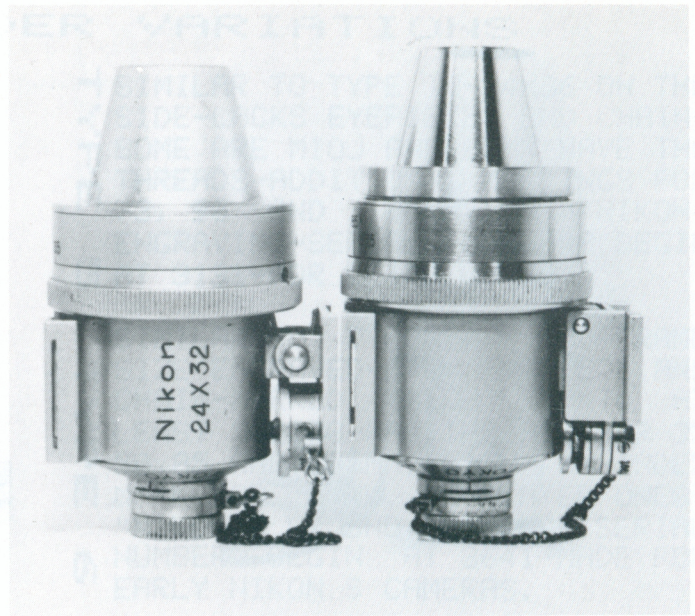

ON THIS PAGE WE FIND NO. 70522 ALONGSIDE TWO EARLY NIKON "M" FINDERS FOR COMPARISON (THESE ARE IDENTICAL TO TYPE 3 EXCEPT FOR THE "M" AND A FRAME SIZE OF 24X34, WHICH IS NOT ENGRAVED) NOTE THE TOTALLY DIFFERENT TYPE OF MOUNTING SHOE AND PARALLAX LEVER USED ON THESE TWO TYPES. NO FRAMESIZE IS ENGRAVED BUT THE WORD "NIKON" IS AROUND THE EYEPIECE. CALIBRATIONS ARE IDENTICAL BUT THE NEWER STYLE NOSEPIECE IS PRESENT AS WELL AS THE BRIGHT CHROME FINISH.

ROBERT ROTOLONI

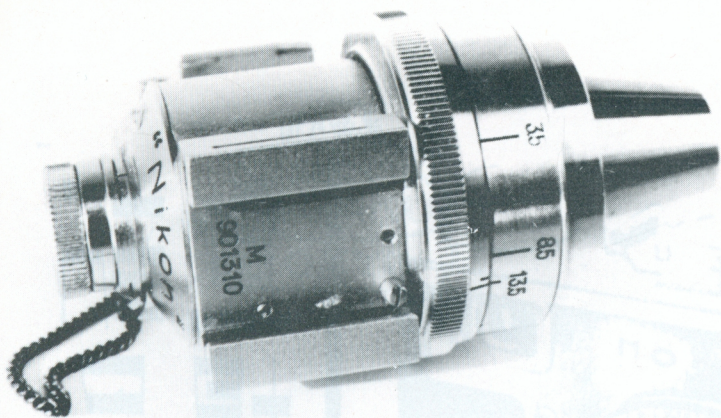

AT THE TOP ARE TWO PHOTOS FROM MEMBER TAD SATO. ON THE LEFT IS THE VARIANT OF TYPE 3(B) MENTIONED IN THE TEXT BUT WITHOUT THE QUOTATION MARKS. THE RIGHT PHOTO IS OF A TYPE TEN FINDER WITH CALIBRATIONS FOR LEICA TYPE LENSES.

NEXT ARE FOUR PHOTOS OF A 28MM. ATTACHMENT BELONGING TO JOHN ANGLE. THIS ITEM IS NOT SERIAL NUMBERED SO QUANTITY CAN NOT BE DETERMINED AT THIS TIME. IT CAME WITH AN UNUSUAL CHROME RING WHICH IS REMOVABLE. WITHOUT THIS RING THE ATTACHMENT WILL MOUNT ON THE VARIFRAMES MADE BY NIKON FOR BOTH THEIR CAMERAS AND THE LEICA TYPES, BOTH OF WHICH HAVE THE SAME THREADS. IT WILL NOT MOUNT WITH THE RING ATTACHED???



又画月刊'47-10

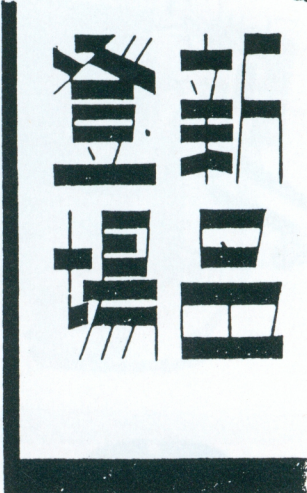
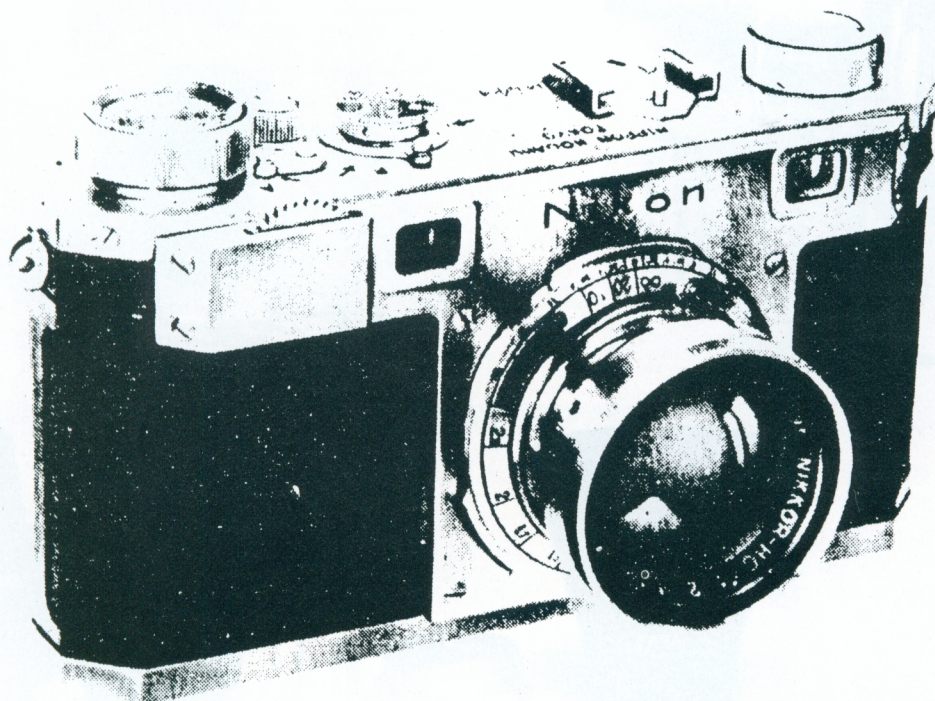

日本光学製
ニコンカメラ

EARLY JAPANESE ADS

BY TSUYOSHI KONNO

MEMBER TSUYOSHI KONNO HAS SENT ME REPRODUCTIONS OF THREE VERY EARLY NIPPON KOGAKU MAGAZINE ADS THAT WERE ORIGINALLY PUBLISHED IN THE JAPANESE PHOTOGRAPHIC PRESS. TWO ARE SHOWN HERE WITH THE THIRD ON THE REAR COVER OF THIS ISSUE.

THE ABOVE APPEARED IN THE OCTOBER 1947 ISSUE OF "KOHGA GEKKAN". IF IT SEEMS FAMILIAR TO YOU IT IS BECAUSE IT IS THE SAME CAMERA THAT APPEARED IN THE LAST JOURNAL ON PAGES 2, 3 AND 9. IT IS SEEN OFTEN IN VERY EARLY NIKON LITERATURE.

ON THE NEXT PAGE IS AN AD FROM THE SAME MAGAZINE, THIS TIME THE OCTOBER 1953 ISSUE. IT IS FOR THE MODEL "S" AND ITS LENSES, PLUS THE CINE-NIKKORS AND 75MM. AND 120MM. LENSES,

POSSIBLY FOR 120 AND PLATE BACK CAMERAS. WHAT IS REALLY SPECIAL ABOUT THIS AD IS THE 50MM. F1.4 NIKKOR ON THE CAMERA. THE BODY NUMBER IS 6104326(?), WHICH IS WITHIN THE FIRST THIRD OF THE "S" PRODUCTION, PLUS REMEMBER THAT THIS AD APPEARED IN OCTOBER 1953. SO WHAT IS IT DOING WITH A "BLACK" 1.4 NIKKOR?????? AND AN ALL BLACK ONE TO BOOT???? UNFORTUNATELY THE SERIAL NUMBER OF THE LENS IS NOT READABLE. IT COULD BE FROM A BATCH OF BLACK F1.4 NIKKORS THAT I HAVE HEARD OF IN THE 331000 TO ABOUT 332000 RANGE. THIS IS VERY EARLY FOR A BLACK LENS AND MAY BE PART OF AN EXPERIMENTAL BATCH.

NOTE THAT THE AD ON THE REAR COVER IS FOR THE NIKON ONE AND MENTIONS THE 50MM. F3.5 NIKKOR.



ニコン S

f / 1.4 f / 2

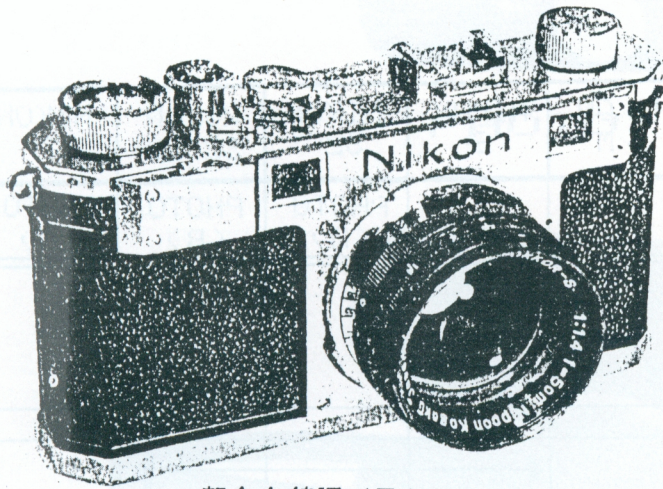

軽合金鏡胴（黒色仕上） f:1.4 付
発売中 です

ニコン用交換レンズ

- 2.8 cm f / 3.5
- 3.5 cm f / 2.5
- 3.5 cm f / 3.5
- 5 cm f / 1.4
- 5 cm f / 2
- 8.5 cm f / 1.5
- 8.5 cm f / 2
- 13.5 cm f / 3.5
- 25 cm f / 4*

(*印のみ近く発売予定)

8mm 撮影機用最優秀鏡玉

シネ・ニッコール

Cine-NIKKOR

13mm f/1.9 38mm f/1.9



ASA マウント

リライアント
リビア
キーストン
等に使用可

ニコンカメラ専用

オロスコーフユニット

75mm 用, 120mm 用

東京・品川・大井森前町

日本光学工業株式会社



PHOTO (A)



PHOTO (B)



PHOTO (C)

**NIKON RANGEFINDER
BIBLIOGRAPHY
PART FOUR
BY CARL JOECKS**

POPULAR PHOTOGRAPHY 1959

- JAN.P.13 WHY A NIKON SP?...SP AD
 FEB.P.19 WHY A NIKON SP?...SP AD
 MAR.P.37 WHEN ACTION.....SP AD
 P.44 WHATS NEW...NIKKOR LENS
 BROCHEURS OFFERED.
 P.74 SHOWS SP WITH MOTOR.
 P.100 SHOWS S3 WITH MOTOR.
 APR.P.43 AT THE PEAK MOMENT...SP
 MAY.P.24 PHILADELPHIA PHOTO SHOW
 HIGHLIGHTS:INTRO OF THE
 NIKON F AND 50MM. F1.1
 WITH OUTER BAYONET.
 P.89 SHOWS PANORAMA HEAD
 AND CLOSE UP ATTACHMENT
 3RD COVER WHEN THE MOMENT..SP AD
 JUN.P.12 PHILADELPHIA PHOTO SHOW
 INTRO OF "F" AND 180,
 250,350,500 AND 1000MM
 LENSES FOR RF.
 P.18 PRICE REDUCTION...SP/S3
 P.19 TODAY NIKON LEADS.SP AD
 P.99 PHOTO SHOW(CONT.)INTRO.
 OF 21,350,1000MM AND
 50/1.1 IN EXTERNAL MOUNT
 JUL.P.20-21 NOW THERE ARE TWO..
 SP SND F AD.
 AUG.P.11 FIRST NIKON F AD.
 P.18 WHATS NEW:NIKON F.
 SEP.P.26 WHATS NEW:BC-5 FLASH
 OCT.P.19 SP AND F AD.
 NOV.P.29 WHY THE MAN...SP AD
 P.40 WHATS NEW:INTRO OF
 NIKON STEREO OUTFIT.
 DEC.P.34-35 SP AND F AD.

JASON SCHNEIDERS FIRST BOOK,
 JASON SCHNEIDER ON CAMERA COL-
 LECTING, IS A REPRINT OF SOME
 OF HIS ARTICLES FROM POP PHOTO.
 IN IT ARE THREE REFERENCES TO
 THE NIKON RANGEFINDERS. THE "S"
 ON PAGE 21, THE NIKKOR LENS ON
 PAGE 100 AND THE SP ON PG. 170.
 THIS IS A GREAT BOOK IN WHICH
 TO READ A CHAPTER A NIGHT.

THE OCTOBER 1955 ISSUE OF
 ART PHOTOGRAPHY, ON PAGE 45, HAS
 AN ARTICLE BY GEORGE GILBERT
 ON JOSEPH EHRENREICH AND THE S2.
 SOME INTERESTING COMMENTS ON THE
 RISE OF THE JAPANESE CAMERA
 COMPANIES.

THE NATIONAL GEOGRAPHIC MA-
 GAZINE HAS ALWAYS BEEN A MEDIA
 FOR FINE CAMERA ADVERTISING. IT
 IS NOT SURPRISING TO FIND IN IT
 ADS FOR THE NIKON S2. WHAT IS
 STRANGE, HOWEVER, IS THAT THE ADS
 ARE IDENTICAL AND APPEAR ONLY
 IN 1956. CHECK OUT THE JUNE AND
 SEPTEMBER ISSUES.

NEXT TIME WE WILL LOOK AT
 SOME COFFEE TABLE BOOKS WHICH
 DISCUSS THE NIKON RANGEFINDER.

NEW MEMBERSNEW MEMBERS**

PAUL-HENRY VAN HASBROECK
 34 BURY WALK
 LONDON SW3 6QB
 ENGLAND

TANEO IMAI
 2-8-8 KITADOHRI,MIYAKOJIMA
 MIYAKOJIMA-KU
 OSAKA 534, JAPAN

JAMES D. MARTIN
 16790 PARKLANE
 LIVONIA, MICH. 48154

W.S.EMERY
 2243 EAST 26TH. ST.
 TULSA, OK. 74114

OLIVER REDDAWAY
 3/5 SIDMOUTH STREET
 READING RG1 4QX
 BERKSHIRE, ENGLAND

TONY HURST
 35 CARYSFORT AVE.
 BLACKROCK
 CO. DUBLIN
 IRELAND

LETTERS TO THE EDITOR

FROM P.H. VAN HASBROECK:

YOUR MAGAZINE IS JUST FANTASTIC. I CANNOT TELL YOU HOW HARD YOU MUST HAVE WORKED TO PRODUCE IT. HAVING BEEN IN SOME SORT OF PUBLISHING MYSELF I CAN REALLY APPRECIATE HOW MUCH HARD WORK GOES INTO SUCH A JOURNAL.

THE PHOTOGRAPHIC QUALITY IS JUST INCREDIBLE AND PLEASE ACCEPT MY SINCERE COMPLIMENTS.

MR. VAN HASBROECK IS BEING VERY MODEST. HIS "SOME SORT OF PUBLISHING" CONSISTS OF THREE VERY BEAUTIFUL BOOKS ON THE LEICA INCLUDING HIS LATEST, WHICH IS BY FAR THE LARGEST AND MOST COMPLETE EVER DONE ON WHAT HAS TO BE THE MOST WRITTEN ABOUT CAMERA IN THE WORLD.

FROM GARY STONE:

JUST A NOTE TO SAY HOW MUCH I ENJOYED OUR PHONE CONVERSATION ON SEPT. 29TH. WHEN I WAS PASSING THROUGH CHICAGO. HAD THE PLANE NOT BEEN LEAVING THEN I AM SURE WE COULD HAVE TALKED FOR HOURS....JUST RECEIVED NHS-5 AND FOR ME IT IS THE BEST YET. I HAVE NEVER SEEN SUCH INTERESTING AND UNIQUE MATERIAL. I HOPE OUR JAPANESE MEMBERS WILL CONTINUE TO SHARE WITH US SOME OF THE INFORMATION THEY HAVE UNCOVERED....OUTSTANDING.

DEAR GARY,

I WISH YOU COULD HAVE BEEN ABLE TO STAY IN CHICAGO A FEW HOURS.....MAYBE NEXT TIME? OUR JAPANESE MEMBERS HAVE, FROM THE BEGINNING, BEEN EXTREMELY WILLING TO SHARE INFO. I HAVE BEEN LITERALLY DELUGED WITH PHOTOS AND PRINTED INFORMATION. I WILL CONTINUE TO USE THE "JOURNAL" AS A CONDUIT FOR THIS INFO AS WELL AS WHAT I RECEIVE FROM THE ENTIRE MEMBERSHIP. NOTE THAT IN THIS ISSUE IS MORE FROM JAPAN IN THE FORM OF EARLY JAPANESE MAGAZINE ADVERTISING COPY.

FROM RANDY REED:

I HAVE FOUND BOTH YOUR BOOKS VERY HELPFUL AND INFORMATIVE. LIKewise, THE "NIKON JOURNAL" IS BENEFICIAL IN TERMS OF HISTORICAL INFORMATION. HERE IS AN OBSERVATION ABOUT YOUR REMARK IN YOUR BOOK ABOUT THE WEIGHT OF THE 85MM. F1.5 NIKKOR. THE LEITZ SUMMAREX WEIGHS 26 OZ. AND THE CANON 85MM. F1.5 WEIGHS IN AT 27 OZ.

DEAR RANDY,

I DID NOT KNOW THE WEIGHTS OF THE LEITZ AND CANON LENSES WHICH ARE CHROME. IT NOW APPEARS THAT NIKON CHOSE TO USE A BLACK BARREL ON THEIR LENS FOR A VERY GOOD REASON. I WOULD CALL THAT GOOD PRODUCT PLANNING. THANKS FOR THE INFO. SOMEDAY IT MIGHT PROVE INTERESTING TO COMPARE THE WEIGHTS OF NIKKORS TO THE COMPETITION.

ADDRESS CHANGES.....

WILLIAM JACKSON, MD.
1721 EAST 19TH. AVE.
PRESBYTERIAN PLAZA
DENVER, COLORADO 80218

F.W. MATTHEWS
62 DRUMMOND ST., APT. 2
AUBURN, ME 04210

NEXT TIME

THE DEADLINE FOR THE NEXT ISSUE OF THE "NHS JOURNAL" WILL BE MARCH 1, 1985. PLEASE HAVE ALL CONTRIBUTIONS TO ME BY THEN.

Classified

wanted

WANTED**** IN AN EFFORT TO KEEP IMPROVING "THE NIKON JOURNAL" I AM IN NEED OF THE FOLLOWING FOR FUTURE ARTICLES//FEATURES I PLAN TO DO.ANY HELP WOULD BE APPRECIATED.....

HIGH QUALITY XEROX COPIES (OR ORIGINALS THAT I WOULD RETURN) OF ANY ADS OR BROCHEURS OR LITERATURE ON THE RANGEFINDERS. I PLAN TO REPRODUCE THESE BOTH ON THE REAR COVER AS WELL AS WITHIN THE JOURNAL AS I DID THIS ISSUE. ALSO SERIAL NUMBERS OF ANYTHING YOU WISH TO SEND ME. I PLAN ON STARTING SERIAL NUMBER LISTS FOR OTHER ITEMS AS I HAVE FOR BLACK BODIES. ALL NUMBERS WILL BE KEPT CONFIDENTIAL. THANK YOU.....ROBERT ROTOLONI.

WANTED**** EYESIGHT CORRECTION LENSES FOR THE NIKON S2 AND S3. 21MM/F4.0 NIKKOR IN LEICA SCREW MOUNT. ZUNOW LENSES WITH NIKON MOUNT SUCH AS 35MM. F1.7, 50MM. F1.1, 50MM. F1.3 AND 100MM.F2.0 AKITO TAMLA SUGINAMI-KU, TAKAIDO-HIGASHI 4-12-19 TOKYO 168, JAPAN

WANTED**** BLACK S2..\$1400.00 NIKON S3M..\$3500.00

TAD SATO 24-719 YANO-CHO HACHIOJI-SHI TOKYO 20 192, JAPAN

WANTED**** 8 5/1.5 AND 50/1.1 NIKKORS MIDJ VARIFRAME TYPE 3 OR 6-85MM CHROME TOKYO FINDER EX OR BETTER.HAVE SOME NIKON AND CANON RF GEAR FOR TRADE. RANDY REED..(619)466-2963

BLACK IS BEAUTIFUL. BLACK IS BEAUTIFUL.

THE FOLLOWING NUMBERS ARE ADDITIONS TO THE LISTS PUBLISHED IN "NHS-4/5". I APPRECIATE THE RESPONSE AND I HOPE THAT OUR LIST OF BLACK BODY NUMBERS CONTINUES TO GROW.

NIKON S2 BLACK BODY ADDITIONS:

6170941 6180754

NIKON SP BLACK BODY ADDITIONS:

6206422

I PLAN TO PUBLISH THE ENTIRE REVISED BLACK SERIAL NUMBER LIST ONCE A YEAR SO KEEP THOSE NEW NUMBERS COMING.....

for sale

NO FOR SALE ADS WERE SUBMITTED FOR THIS ISSUE. LOOKS LIKE WE ALL WANT WANT WANT.....

##HAPPY NEW YEAR##
##HAPPY NEW YEAR##
##HAPPY NEW YEAR##
##HAPPY NEW YEAR##
##HAPPY NEW YEAR##
##HAPPY NEW YEAR##
##HAPPY NEW YEAR##
##HAPPY NEW YEAR##
##HAPPY NEW YEAR##
##HAPPY NEW YEAR##

odds 'n ends

THIS PAGE WILL BE RESERVED IN FUTURE ISSUES OF THE NIKON JOURNAL FOR THE RARE, THE UNUSUAL OR OFFBEAT, OR JUST THE OUT OF THE ORDINARY. IF YOU HAVE

ANYTHING THAT YOU FEEL IS DIFFERENT OR UNUSUAL PLEASE SEND ME AT LEAST TWO VARIED VIEWS OF YOUR ODDITY.

THANK YOU.

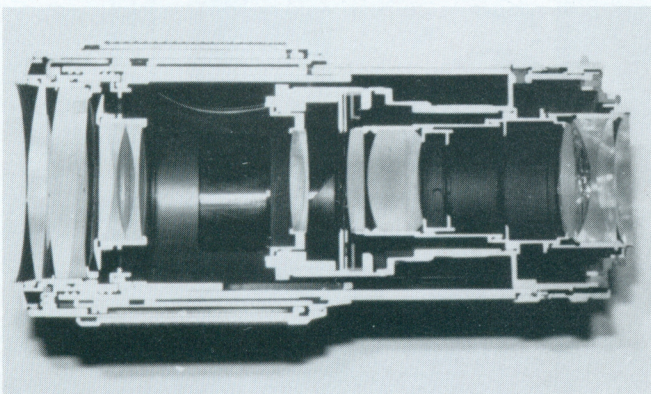

MANY OF US HAVE SEEN CUT-A-WAYS IN VARIOUS LITERATURE FROM MANUFACTURERS. I HAVE ALWAYS WONDERED WHERE THOSE PIECES OF EQUIPMENT WENT TO ONCE ALL THE PROMO SHOTS WERE TAKEN. I HAVE YET TO GET CLOSE TO ANY FROM THE RANGEFINDER ERA BUT THIS ISSUE WE HAVE SOME SHOTS OF A NIKON CUT-A-WAY FOR THE REFLEX CAMERAS. JOHN ANGLE RECENTLY ALLOWED ME TO PHOTOGRAPH A REAL NIKON CUT-A-WAY. IT IS AN 80 TO 200MM. F4.5 NIKKOR ZOOM FROM THE PRE "AI" AND "IC" ERA. IT IS THE HALF WITHOUT THE SERIAL NUMBER SO AN EXACT VINTAGE IS UNKNOWN. IT IS AN EXTREMELY IMPRESSIVE PIECE, WHAT WITH 15 ELEMENTS AND ALL THOSE CAMS VISIBLE. AT THIS TIME IT IS NOT KNOWN HOW MANY OF THESE NIKON MADE NOR HOW MANY SURVIVED. I HAVE HEARD THAT WHEN THEY MAKE A CUT-A-WAY ONE OF THE HALVES IS USUALLY DESTROYED IN THE PROCESS. ADD TO THIS THE FACT THAT NO MANUFACTURER WOULD CUT TOO MANY ITEMS IN HALF, ESPECIALLY SUCH AN EXPENSIVE LENS AS THIS, AND ONE CAN IMAGINE HOW UNCOMMON THEY MUST BE.

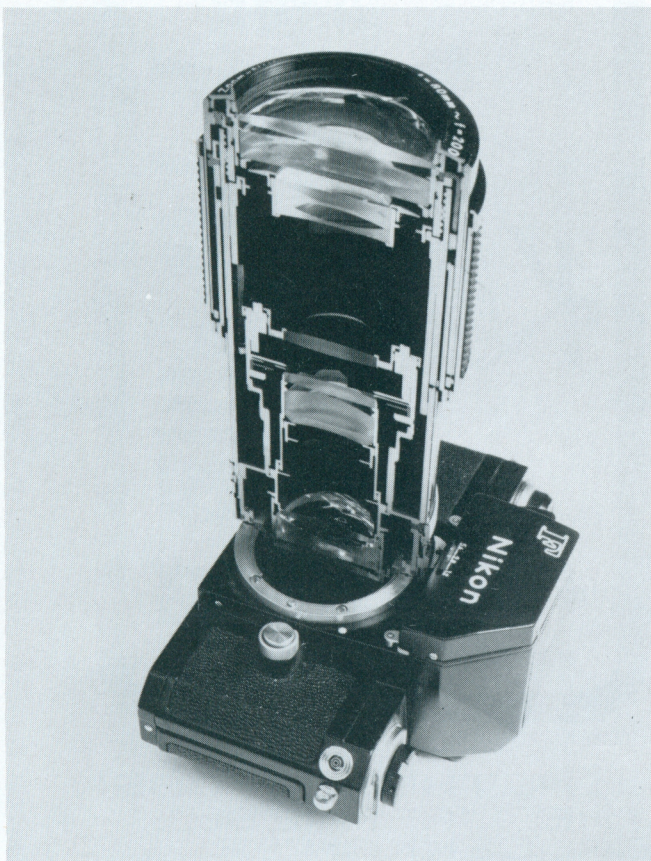

待望の精密小型カメラ

Nikon

24 × 32 ^m/_m
コン判40枚撮

愈々發賣!!

理想的畫面寸法・基線
長6種の精密距離計と
連動する自動焦點・迅
速なるレンズ交換・確
實なるシャッター作動

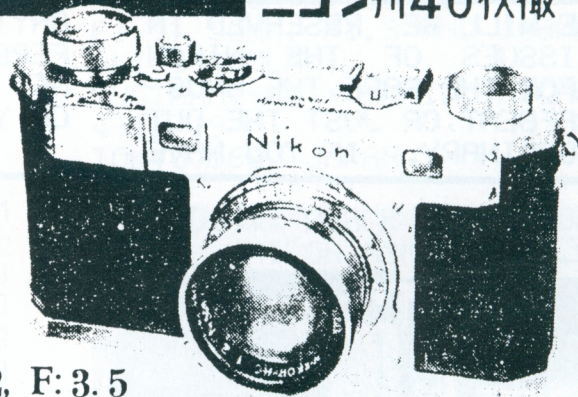

ニッコール (5cm) F: 2, F: 3.5

日本光學

東京都品川区大井森前町 · 日本光學工業株式會社

光画露出計

一回転で・
直ちに正確な露出の
知られる光画露出計

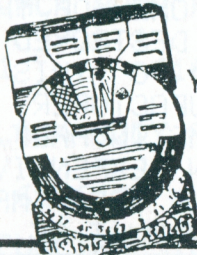

Y 40.
T 2.

全国著名材料店に
て御買求め下さい

北野邦雄写真機叢書 発売中

ロライ型カメラ 30. 円2.

マミヤシックスの使い方 30. 円2.

光画荘

新發特許出願中

新製品!

自由雲台付の



多くの内外三脚の特長を
取入れ具備した
機能の精巧を誇り得る逸品!

(説明書呈 郵券要)

發賣元

村上商会本店

東京 新橋交叉點 電話 銀座(57) 5050, 5095

THIS AD APPEARED IN THE OCTOBER
1947 ISSUE OF THE JAPANESE
MAGAZINE "KOHGA GEKKAN".
SUBMITTED BY TSUYOSHI KONNO.