

finn's **cameras**

Wabasha at 4th
CA. 2-1877 ST. PAUL, MINN.



VITOMATIC III

24 x 36 · 35 mm

INSTRUCTIONS FOR USE

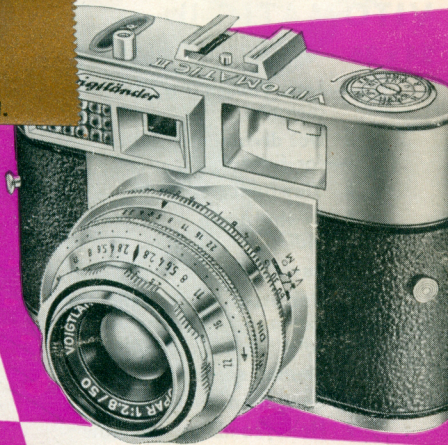

Right Here

is the first and most important piece of advice for the VITOMATIC II: Please read this booklet carefully. Make yourself thoroughly familiar with all the operations and controls of the camera. Then you can load your first film and begin to take pictures.

Remember also that the VITOMATIC II is an optical and mechanical precision instrument which requires gentle and sensible treatment. The camera will repay careful handling with beautifully clear and sharp pictures for many years to come.

VOIGTLÄNDER A. G. BRAUNSCHWEIG



The 2 inch (50 mm.) COLOR-SKOPAR f 2.8

fitted to your camera is a four-element unit, and is one of the series of Voigtländer high-class anastigmat lenses. It meets every requirement for optimum image quality: excellent definition, high brilliance, and maximum resolution over the whole picture area – coupled with absolutely faithful colour rendering in colour photography.

– The Color-Skopar is focused by the movement of the whole lens system as a self-contained optical and mechanical unit. It goes without saying that all air-glass surfaces are hard-coated with a vacuum evaporated anti-reflection layer.



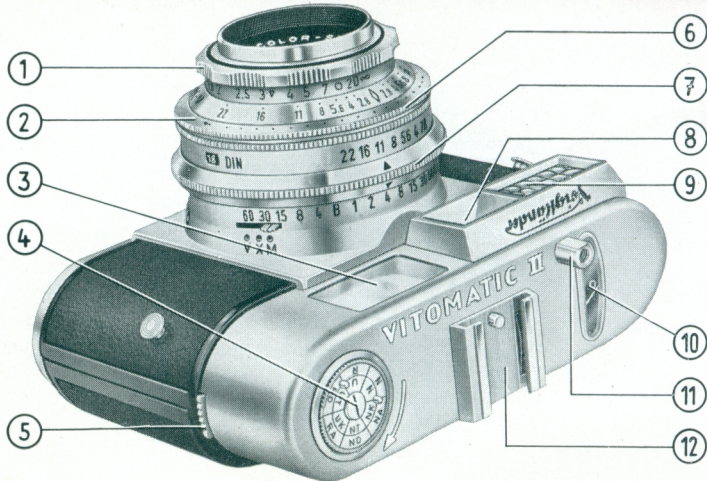

VITOMATIC II

24 x 36 — 35 mm

- | | |
|--|---|
| <ul style="list-style-type: none"> 1 Lens Focusing mount with distance scale 2 Dot divisions on setting ring (6) for filter factor adjustment 3 Viewfinder window 4 Rewind knob with film indicator 5 Reversing lever 6 Universal setting ring for exposure readings, combined with film speed setting ring 7 Shutter speed ring 8 Rangefinder window 9 Honeycomb cell window of exposure meter | <ul style="list-style-type: none"> 10 Exposure meter setting window 11 Release button with cable release socket 12 Accessory shoe 13 Depth of field scale 14 Setting window (DIN or ASA) for film speeds 15 Shutter speed scale 16 Synchronizing lever for M and X synchronization and self-timer (V) 17 Distance scale 18 Aperture scale 19 Setting marker of exposure meter 20 Exposure meter needle |
|--|---|

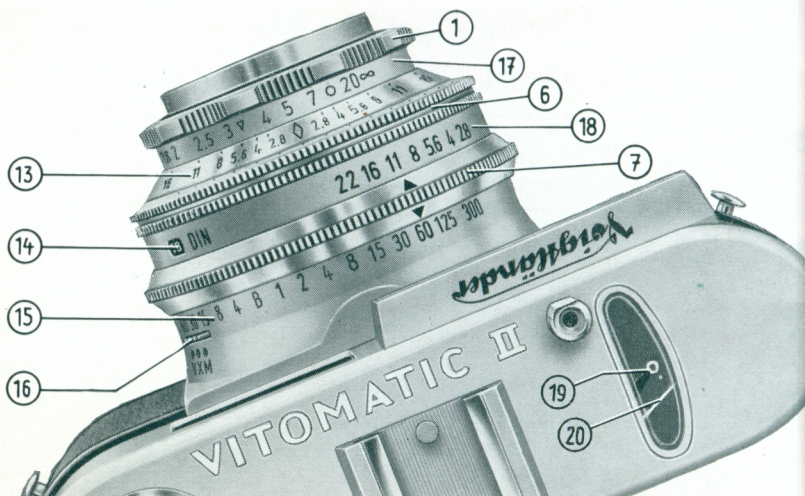

Contents

	Page
Opening the camera and inserting the film	2—4
Setting the film counter	5
Unloading the camera	6
Changing partly exposed films	7
Setting shutter speeds and apertures	8—11
The self-timer (delayed action release)	11
Setting the distance	12—13
The rapid winder — the double exposure lock	14
The crystal bright-line frame finder	15
Flash exposures	16—19
Using filters	20—21
Close-ups with Proximeter	22
Hints for using the exposure meter	23—27
Aperture and depth of field	28

Loading and unloading the Camera

Standard 35 mm. miniature film for 24x36 mm. negatives is commercially available as black-and-white as well as colour film in daylight cassettes of 36 or 20 exposures.

Although the cassettes are light-tight, it is advisable not to expose them to strong light. Make a point therefore of always loading and unloading the camera in the shade – even the shadow of your own body will do.



➡ **Opening the Back**

First lift up the base plate latch (25), and turn it through a quarter turn to the right. Then fold away the base plate flap (24) as shown in the illustration, and swing open the back from the body.

➤ Inserting the Cassette

● Pull out a short length of the film leader from the cassette, and push it into the slit of the take-up spool (27) as far as it will go (see illustration).

● Draw the cassette across the film track, and insert it in the cassette chamber (23). The shaft (22) of the rewind knob must properly engage the cassette, otherwise you will not be able to close the camera later on.

● Now push the reversing lever (5) backwards (making the rewind knob (4) jump up), and keep pulling out the rapid winding lever (28) until the film leader is firmly rolled round the take-up spool, and the transport sprocket (26) engages the film perforations. Then push the rewind knob back again.

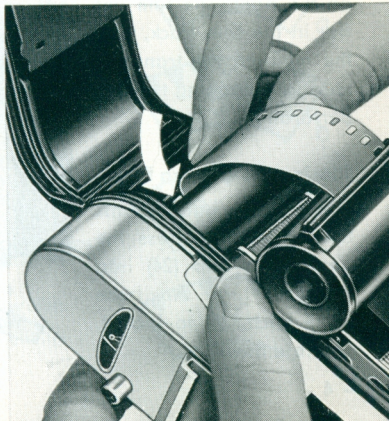

Before closing, the loaded camera must appear as shown in the illustration on the right. The film lies flat in the film track, with the teeth of the transport sprocket engaging the film perforations

➔ **Closing the Camera Back**

First push the back against the body, then press the base plate flap (24) into position, turn the base plate latch (25) to lock it, and fold down.

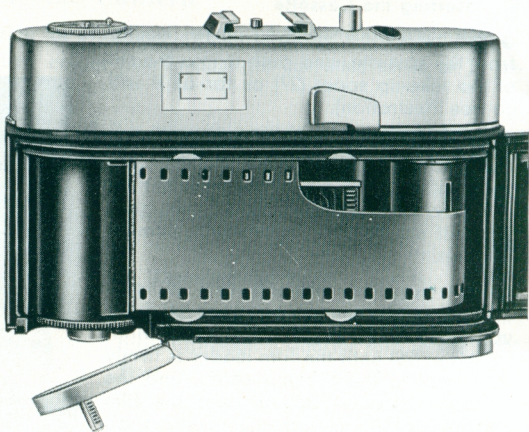

► Setting the Film Counter

Every time the film is advanced, the film counter shows the number of exposures still available. It thus runs backwards from No. 36 or 20 (the first exposure) to No. 1.

With 36-exposure cassettes: Turn the milled knob (30) until the red letter "F" appears below the index mark (a). Pull the rapid winder (28) once or twice until it locks, press the release button (11) and once more work the rapid winder until it locks again. The red figure 36 is now opposite the index mark (b), and the film is ready for the first exposure.

With 20-exposure cassettes: Turn the milled knob (30) until the red figure 22 is opposite the index mark (c). Then proceed as above until the figure 20 appears in the film counter window (d) for the first exposure.

The film indicator in the rewind knob (3) is intended solely as a memory aid. Set it by turning to the appropriate symbol:

RD (UT)	=	Daylight type reversal colour film
RA (UK)	=	Artificial light type reversal colour film
ND (NT)	=	Daylight type negative colour film
NA (NK)	=	Artificial light type negative colour film
N (N)	=	Black-and-white negative film
R (U)	=	Black-and-white reversal film



➔ Unloading

After the last frame the exposed film must be rewound from the take-up spool into the daylight cassette:

Push back the reversing lever (5); the rewind knob (4) will spring up into its operating position (see illustration).

Turn the rewind knob in the direction of the arrow while observing the film counter window. The film counter now runs back from No. 1 (last exposure). When after No. 36 or 20 the red letter "F" or the red mark for No. 22 respectively is below the index mark, the film is fully rewound. The cassette can then be removed from the camera.

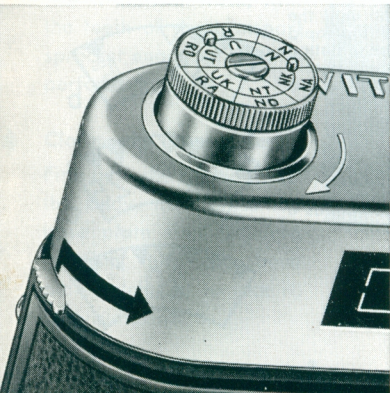

Changing Partly Exposed Films

With the VITOMATIC II you can at any time take out a partly exposed film and change over to another one (e. g. from black-and-white to colour) without the need for a darkroom:

- Rewind the partly exposed film into its cassette, as already described on page 6. Make a note, however, of the last number that appeared in the film counter window.
- When re-inserting the partly exposed film, proceed in the same way as described on pages 3 to 5 up to setting the film counter to "F" or to No. 22.
- Then push back the reversing lever (5), letting the rewind knob (4) spring up. Keep pulling the rapid winding lever (28) fully to the right until the number following the number originally noted appears in the film counter window (21) below the red index mark.

Finally push back the rewind knob (4), pull the rapid winding lever (30) once more as far as it will go, and carry on exposing the film in the normal way.

The Perfect Automatic Exposure System

of this camera gives you at the same time the maximum certainty of correctly exposed pictures, and a hitherto inconceivable simplification in operation.

I A single turn of the universal setting ring covers the whole aperture-speed scale in one continuous range, and brings the setting pointer of the exposure meter to coincide with the meter needle at any reading.

In other words, without having to engage or disengage any sort of coupling, and completely independently of the shutter speed or aperture set, you in effect use the shutter to take the meter reading. In that way you automatically set a correct aperture-speed combination on the camera according to the prevailing light conditions. In case the index-mark is in between two speeds **let it click into position** opposite the figure next to it.

The VITOMATIC II provides this refinement with the new Prontor SLK-V shutter in the special version, coupled with the built-in photo-electric exposure meter.

➤ Setting the Film Speed

Fully depress the lever (21), and turn the front milled rim (see white arrow) of the universal setting ring (6) until the required film speed figure appears in the DIN or ASA window (14). Release the lever again, and the front rim is once more coupled with the universal setting ring.

A comparison table of film speed systems is given on page 27.

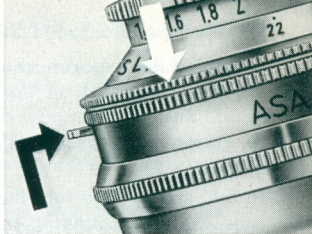

➤ Taking the Meter Reading

Point the camera at the subject, and turn the universal setting ring (6) to the left or right until the white circle of the setting marker (19) coincides with the exposure meter needle (20), as shown in the illustration on the right. Take care, however, not to obscure the honeycomb cell window (9) with your finger.

You will find further useful hints on taking exposure readings on pages 23 to 27.

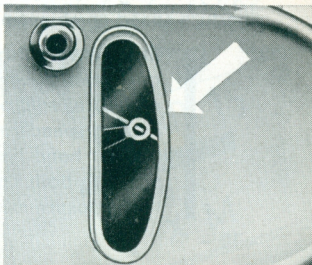

► The Aperture-Speed Settings

By taking the exposure reading as described on the previous page, you have at the same time set an aperture-speed combination to suit the prevailing light conditions. You can now shoot, unless you wish to use a different shutter speed (e. g. for moving subjects) or a different aperture (for greater depth of field – see page 28).

In that case simply turn the shutter speed ring (7) to the required speed or aperture; the corresponding aperture or speed respectively can be read off immediately. A single turn of the shutter speed ring thus covers the whole range of aperture-speed combinations suitable for your subject.

But please note: Once you have taken the exposure reading, do not move the universal setting ring (6) any more, otherwise the effective exposure will be altered. The same also happens if you turn the shutter speed ring (7) so that the black double index  goes beyond the left hand limit (f/22) or the right hand limit (f/2.8) of the aperture scale. In both cases the setting marker would no longer coincide with the exposure meter needle.

- The black figures on the shutter speed scale ($1/300$ to $1/60$ second) are the usual safe speeds for hand-held shots.
- The orange figures ($1/30$ to 1 second) are also speeds which are timed automatically by the shutter upon pressing the release button (11). However, at these speeds a firm support for the camera (e. g. a tripod, or a smooth supporting surface) is desirable during the exposure.
- When setting on green "B" the shutter will remain open as long as the release is depressed. It is recommended to use a cable release which screws into the release button (11). (On the scale "B" corresponds to 2 seconds within the scale.)
- The green figures (4 to 60 full sec.) are auxiliary values. Such long exposure times are not foreseen in the shutter mechanism. They indicate possible exposure times when the speed ring (7) is set to "B" and the diaphragm scale allows further speed-and-diaphragm combinations for poor light conditions. After selecting the appropriate combination, turn back the setting ring (6) until the desired diaphragm figure is opposite the mark ▲ and then expose.

➤ The Self-timer

When you have set the correct aperture-speed combination and the distance and have tensioned the shutter, set the synchronizing lever (14) to "V" (see illustration). On pressing the release, the shutter will now run down on its own after a delay of about 8 seconds, while the synchronizing lever automatically returns from "V" to "X". Do not use the self-timer when the shutter is set to green "B".

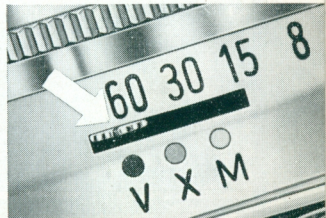



Setting the Distance

is particularly easy with the VITOMATIC II: In the centre of the crystal bight-line frame finder you can see the bright circular rangefinder field. As long as the rangefinder is not correctly focused on the subject, the latter appears with double outlines in the rangefinder field (see top illustration).

Turn the lens focusing mount (1) to fuse the double outlines in the rangefinder field into one. This sets the lens exactly to the measured distance (see bottom illustration).



With horizontal shots, focus always on vertical outlines; with upright shots use horizontal lines of the subject.

➤ Zone Focusing

Candid action shots (for instance of children at play) often yield surprisingly live pictures. On such occasions don't waste time by setting the exact distance. Instead, set the focusing scale to the near zone mark ∇ for subjects between 8 and 17 feet, and to the far zone mark \circ for subjects between 16 feet and infinity.

You must, however, stop down to at least f/5.6 (marked in red) to ensure adequate depth of field.

Provided the light is good enough, these focusing zones are very useful when photographing sports subjects, where subject distances may change very suddenly.

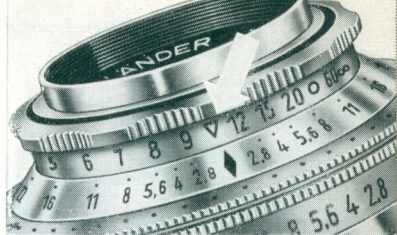

The Rapid Winding Lever

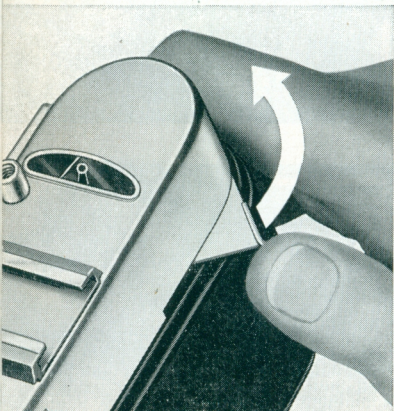

One full movement of the lever tensions the shutter, and advances the film and the film counter. A spring then returns the lever to its original position.

The rapid winder can of course also be worked in a number of short movements. In that case keep pulling the lever until it locks. An automatic lock prevents the rapid winder from being operated a second time before the shutter is released. Conversely, the shutter can only be released after operating the rapid winding lever.

This prevents both double exposures and blank frames. If the camera is empty, the rapid winder moves freely without tensioning the shutter.

The Crystal-Bright-Line-frame Finder

This really unique finder not only shows the subject in full natural size, but you can also keep the other eye open and thus observe the surroundings of the subject as well. This is a special asset when taking candid action shots. The marvellous brilliant image frame clearly outlines the exact field of view.

Note that with near subjects at about 3 feet from the camera the field of view in the finder is displaced downwards or sideways, according to whether the camera is held horizontally or upright. This is indicated by the two short marks in the crystal bright-line frame (see illustration page 12).



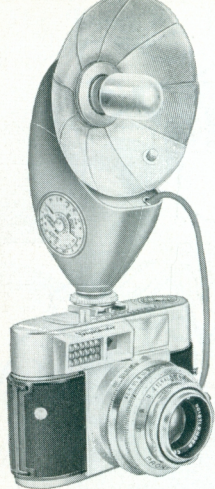

Flash Shots

The PRONTOR SLK-V shutter permits synchronized flash shots up to the fastest shutter speed of $1/300$ second with any flash gun or electronic flash unit on the market.

Please Note:

With black-and-white film the flash (clear or blue bulbs, or electronic flash) can be used on its own, or combined with daylight or artificial light sources such as tungsten lamps.

When using a flash for colour-films (artificial and day-light) we recommend to observe exactly the instructions for use of these films. In case of doubt please contact your photo-dealer.

Small light-weight units such as the Voigtländer battery-capacitor flash gun can be fitted directly into the accessory shoe (12) of the camera (see illustration on the left). Larger flash guns or the flash holders of electronic flash units are generally fitted to the side of the camera by means of a special bracket.

The flash cable completes the electric circuit between the flash unit and the camera shutter. Push the plug of the flash cable into the flash socket (33), as shown in the illustration.

Warning: Never use the shutter contacts to fire flash bulbs from the usual 110 or 220 volt mains.

➔ **Mounting the Flash Gun
on the Camera**

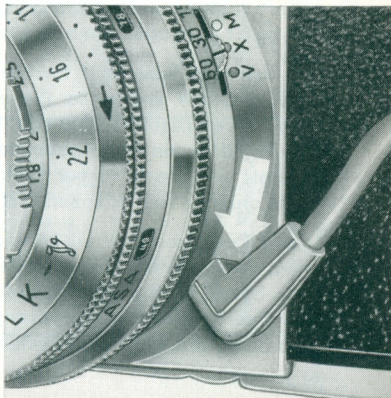

➤ Setting the Shutter and the Aperture

Flash bulbs and electronic flash units differ in their characteristics such as the firing delay and light output; the table opposite classifies them in several groups. To ensure that the peak brightness of the flash coincides with the instant when the shutter is fully open, there are two types of synchronization: "M" and "X".

Before taking a flash shot therefore move the synchronizing lever (16) of the PRONTOR SLK-V shutter to the yellow dot marked "M" or to the red dot marked "X", as required. You can then use all types of flash and all the shutter speeds listed in the table opposite under "M" or "X" respectively. **Note:** For flash shots with the self-timer (with the synchronizing lever set to the green dot "V") use only the shutter speeds listed in the table under "X".

The lens aperture required for correct exposure can be obtained from the so-called guide number. This is usually quoted on the flash bulb packing or in the leaflets issued by the makers of the bulb or electronic flash unit. To find the correct aperture, divide the appropriate guide number by the distance in feet between the flash and the subject. In short: **Aperture = guide number : distance.**

Suitable Shutter Speeds

Flash Bulbs		Synchronizing Lever Set to	
Make	Type	X	M
Gen. Electric West Electric	} SM	1 to 1/125	Not suitable for M-syn- chronization
West Electric			
Sylvania West Electric	} SF		
Philips			
Osram	XM 1	1 to 1/30	1/60 to 1/300
Philips	PF 5		
Osram	XM 5		
Gen. Electric Sylvania	} M 2		
West Electric			
West Electric	0		
West Electric	3		
West Electric	} 5		
Gen. Electric			
West Electric	P 5		
Gen. Electric Sylvania	} 8		
Sylvania		25	
Electronic Flash Units		Synchronizing Lever Set to X	
Type			
Instantaneous firing		1 to 1/300	

Voigtländer Filters

are made of spectroscopically tested optical glass, dyed in the mass, and coated to reduce reflections (ϕ 32 mm.). The filter factors given below are approximate values, as they necessarily depend on the colour sensitivity of the black-and-white film used, and on the light conditions prevailing at the time of the exposure.

- Yellow filter G 1.5 x** Slight filtering effect for outdoor shots requiring short exposure times, such as sports and action subjects, and pictures with low sun.
Filter factor: 1½ times.
- Yellow filter G 3 x** Universal filter for landscapes and other outdoor subjects, indispensable for snow pictures.
Filter factor: 3 times.
- Green filter Gr 4 x** Lightens green tones in landscapes. Recommended for artificial light portraiture and copying of coloured originals.
Filter factor: 4 times.
- Orange filter Or 5 x** Strong filter effects by considerable suppression of blue light. Reduces atmospheric haze in distant views.
Filter factor: 5 times.
- Ultra-violet filter UV** Cuts out ultra-violet radiation in high mountains or near the sea. Eliminates any unpleasant blue casts in colour shots. Requires no exposure increase.

▶ Setting the Filter Factors

The use of any filter (except the ultra-violet filter) during the exposure requires a certain adjustment of the exposure setting. With the VITOMATIC II you can carry out that adjustment on the shutter. For this purpose you use the dot divisions (2) at the side of the universal setting ring (6). Mark for dot divisions is the same as for the one on the scale for depth of field ↓.

Example A: For a factor of $1\frac{1}{2}$ times turn the universal setting ring to the left by half a division in the direction of the arrow. For a factor of 3 times move it by one and a half divisions, for a factor of 4 times by two divisions, and for a factor of 5 times by two and a half divisions. In every case you therefore adjust the aperture setting according to the filter factor required. – If however the aperture-speed combination has reached the limit of f/2.8 on the aperture-scale, you have to turn the universal setting ring to adjust the shutter speed according to the required filter factor. Note: when setting half divisions, always set the shutter to the next longer exposure time first.

Example B: If the aperture-speed combination obtained is 1 second at f/2.8 (the lowest limit of exposure readings), set the filter factor as follows:

For a factor of $1\frac{1}{2}$ times advance the universal setting ring by one whole division (to "B" at f/2.8), turn it back half a division, and expose for $1\frac{1}{2}$ seconds.

For a factor of 3 times advance the universal setting ring by one division (to "B" at f/2.8) and expose for 3 seconds.

For a factor of 4 times advance the universal setting ring by one division (to "B" at f/2.8) and expose for 4 seconds.

For a factor of 5 times advance the universal setting ring by one division (to "B" at f/2.8) and expose for 6 seconds.

Close-ups with Proximeter

Large-scale views of objects and animals, or full-frame copies of pictures and documents, which are particularly fascinating and interesting subjects, are made really simple with the Voigtländer Proximeter.

The special advantage of this ideal close-up attachment is, that it permits hand-held close-up shots with the camera instantly ready for action — an important point with live or rapidly moving subjects. At the same time the viewfinder parallax at close distances is automatically eliminated, and lens and rangefinder as result are coupled as same as in the normal zone from 3 feet to infinity.

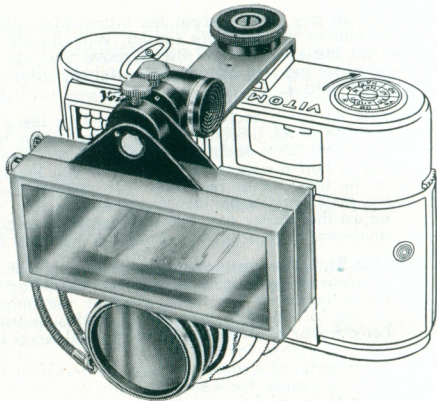

Hints for Using the Exposure Meter

Generally it is sufficient to point the exposure meter at the subject from the camera position, thus measuring the light reflected from the subject. Such reflected light readings are suitable for all average subjects which show no excessive contrasts of light and shade and which are not set against an exceptionally light or dark background.

With outdoor shots, especially open views, the sky nearly always occupies part of the subject area, and thus part of the view of the exposure meter. As however the brilliant sky reflects much more light than the subject itself (the landscape, buildings, animals) it is advisable to point the camera slightly downwards when taking a reading.

Exceptions are shots of interesting cloud formations where foreground details such as buildings or figures are purposely intended to record only as silhouettes. The same applies to snow and seascapes. Pictures of people in the snow or on a brilliant beach, however, always call for close-up readings (see next page).



In some cases close-up readings are necessary for more accurate reflected light measurement. Examples are:

- Light subjects against a dark background, and vice-versa;
- Close-ups of small objects and animals;
- Nearly all pictures of people, especially portraits (see illustration).

In this case only the important parts or the subject should be used to determine the brightness range.

When taking a close-up reading, approach the subject sufficiently closely so that the selenium cell of the exposure meter only receives the light reflected by the individual subject areas. If necessary, measure two or three extreme tones, and take a medium value. Always watch that the shadow of the camera or of your own body does not obscure the part from which you are taking a reading.

Note this rule-of-thumb for close-up readings: The exposure meter should not be farther away from the measured area than the width of that area.

With tricky subjects or situations involving extreme brightness differences between the subject and its background or surroundings (e. g. against-the-light shots, snow subjects), incident light measurement is often more useful.

In that case mount the diffusing screen in front of the exposure meter window (9), and take the reading from the subject in the direction of the camera position to be used. This then measures the light actually reaching the subject. Incident light measurement is also successful with interiors with or without artificial light, for the diffusing screen extends the acceptance angle of the exposure meter.

A diffusing screen is enclosed with every VITOMATIC II, and can be carried in the ever-ready case of the camera.

However, please note: With incident light readings correct exposure will of course also depend on the amount of light the subject is able to reflect. For obvious reasons it is not possible to quote any correction factors for that. You will therefore be well advised to base exposures with incident light readings on your own previous experience.

Exposure with Colour Shots

Exposure readings for colour pictures are taken in the same way as for black-and-white film. Note however that reversal colour film has a very limited exposure latitude and therefore needs specially careful readings.

To make quite certain of correct exposure – especially with reversal colour film – it is advisable to calibrate the meter for the camera and film by a few exposure tests. When you first try out a colour film therefore choose several interesting subjects and expose a frame on each one with the aperture-speed combination indicated by the exposure meter. At the same time make additional exposures of the same subject from the same viewpoint and in the same light, but giving half a stop and one whole lens stop above and below the basic setting.

Overexposure of reversal colour film yields a very light transparency which may however still be usable. Underexposure results in excessively dark images. The density of the transparencies should be judged on projection.

Comparison of Film Speed Systems

The VITOMATIC II can be set to various ASA or DIN film speeds. The actual values marked are those, which correspond to most colour and black-and-white film-ratings on the market (see bold figures in table).

However there are two more ratings, which are quite often used those of 32 and 10 ASA. For these films you find a white point near the next higher or lower film speed. Let the setting ring click into position right there. All other ratings not marked can be set also by adjusting the ring (page 9) to an intermediate setting.

For film ratings of other film speed systems use this comparison table (DIN, BSI and Weston) to get the correct film speed corresponding to those on the setting ring.

ASA	DIN	BSI	Weston
10	11°	21	8
12	12°	22	10
16	13°	23	12
20	14°	24	16
25	15°	25	20
32	16°	26	24
40	17°	27	32
50	18°	28	40
64	19°	29	50
80	20°	30	64
100	21°	31	80
125	22°	32	100
160	23°	33	125
200	24°	34	160
250	25°	35	200
320	26°	36	250
400	27°	37	320
500	28°	38	400

Aperture and Depth of Field

The depth of field covers that part of the subject area in front of, and behind, the focused distance which appears acceptably sharp in the picture. The extent of this sharp zone is by no means constant: it increases the more you stop down the lens, and decreases the larger the lens aperture. In short:

Large apertures (e. g. $f/4$) **yield limited depth of field;**

Small apertures (e. g. $f/11$) **yield greater depth of field.**

The available depth of field zone is easily determined. After you have set the lens to the correct subject distance, look at the depth of field scale (13). This carries two series of aperture numbers arranged symmetrically to the left and to the right of the \blacklozenge index. The depth of field then extends from the distance marking opposite one of the left hand aperture figures to the distance marked opposite the corresponding right hand aperture figure (see the illustration of zone focusing on page 13).

Care of the Camera and Lens

Successful results and long life of your VITOMATIC II depend largely on proper care and correct operation.

- Therefore always handle the camera gently, and never use force. In particular, protect the camera against hard knocks, and do not drop it. If you travel by car, do not keep the camera in the glove compartment or on the rear parcel ledge. In the long run such a "vibration test" will not do any good to the built-in photoelectric exposure meter.
- For cleaning the lens use only a soft fluffless cloth. However, first remove coarse particles of grit (or sand at the seaside) carefully with a soft sable brush. Finger marks or other traces of grease on the lens surface can be removed with a piece of cotton wool moistened with pure alcohol or ether.
- In the case of any trouble consult your photo dealer, or post the camera to the Voigtländer agent in your country or to the Service Department, Voigtländer A. G., Braunschweig, Western Germany.

We guarantee this camera against defects due to faulty materials or workmanship according to present-day standards of technical perfection. Should any such defects become apparent, they will be rectified free of charge if the claim is made within a reasonable period after purchase. We cannot entertain claims for further damages, consequential or otherwise, or for the free repair of faults due to incorrect handling or storage.

WARRANTY

VOIGTLÄNDER A. G. BRAUNSCHWEIG

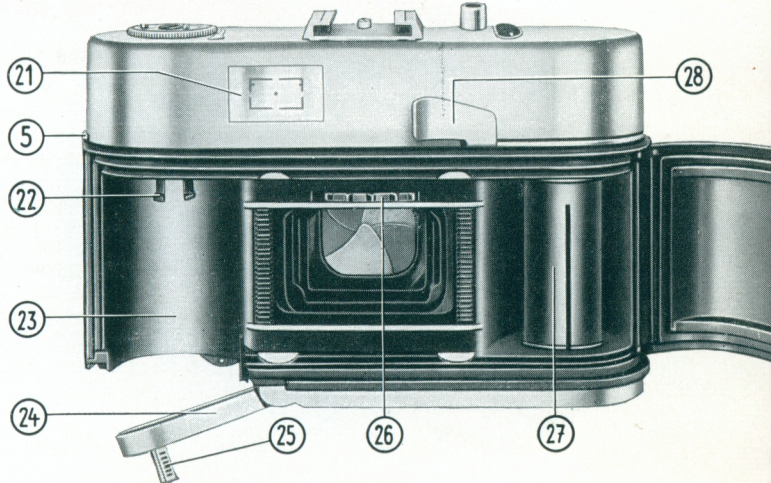

- | | |
|---|---|
| <p>5 Reversing lever</p> <p>6 Universal setting ring for exposure readings, combined with film speed setting ring</p> <p>7 Shutter speed ring for setting the correct aperture-speed combination after taking the exposure reading</p> <p>21 Viewfinder eyepiece</p> <p>22 Shaft of rewind knob</p> <p>23 Cassette chamber</p> <p>24 Base plate flap</p> <p>25 Base plate latch</p> | <p>26 Sprocket to operate shutter, film counter and double interlock</p> <p>27 Take-up spool</p> <p>28 Rapid winding lever to advance the film and cock the shutter</p> <p>29 Lever to uncouple the film speed setting ring (see No. 6)</p> <p>30 Milled film counter setting knob</p> <p>31 Film counter window</p> <p>32 Tripod bush</p> <p>33 Flash socket</p> |
|---|---|

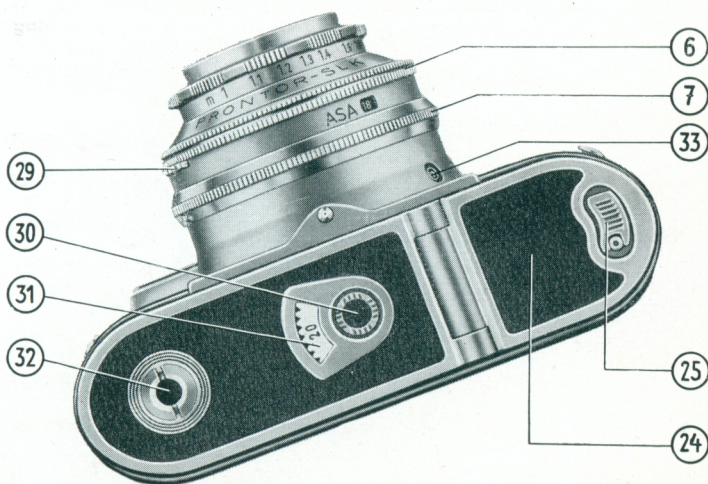



YOUR
PHOTO
ADVISER

finn's **cameras**

Wabasha at 4th
CA. 2-1877 ST. PAUL, MINN.

151 09 - 13 A/1158 

Subject to alterations / Printed in Germany