

Konica FP-1

35mm slr camera

Cat. No. 702-800



The Konica FP-1 offers a new concept in SLR cameras — total automation. Apertures and shutter speeds have been programmed to provide precise exposures in all situations. In keeping with the Konica pioneered theory of shutter priority automation the program of the Konica FP-1 is based on the selection of the fastest shutter speed. The sophisticated CPU (Central Processing Unit) directs the multiple functions of the camera and electronically controls all of its sequential operations. With its many built-in technological advancements the Konica FP-1 is small, light and easy to use.

Key Features

- Auto Exposure. Famed Konica “shutter preferred” system is the basis for the unique totally programmed exposure system. The exact shutter speed and aperture will be automatically set for every lighting condition. The shutter speed of the Konica FP-1 may be manually set to 1/100 second by setting the lens in the manual position.
- Self Load — Self Start. Film loading is quick, easy, precise. Drop in any standard 35mm cassette, extend the leader and close the back. Wind the film advance lever and it will stop automatically at frame number one. There is no need to press the shutter release button after each advance of the film lever. When using the Konica Autowinder F, the film will be advanced to frame number one automatically.
- Konica Autowinder F available as optional accessory, to increase the versatility of the Konica FP-1. Shoot single frame or continuously at 1.5 frames per second - with correct exposure automatically set for each frame. Extremely lightweight (just 6.5 oz.). Couples to the Konica FP-1 automatic film loading system.
- “Control Center” viewfinder gives all necessary information. Three separate focusing aids (split image rangefinder, microdiaphragm ring, fine ground glass circle) in center of screen for quick, accurate focusing. Green LED glows to show proper exposure and blinks as “flash ready” indicator. Red LED glows to show under exposure and blinks as “manual operation” indicator.
- Auto Flash. The FP-1 computer automatically advises the Konica Dedicated Electronic Flash of the ASA speed of the film, and adjusts lens aperture and shutter speed for correctly exposed flash pictures.
- Accessory Terminal Connector allows the use of unique Konica accessories such as Left Hand Release, Interval Timer and Electronic Cable Switch.
- New compact, Color Dynamic Coated, Hexanon 40mm f1.8 lens. Fully automatic, manual override. Slightly wide angle coverage for increased field of view, greater depth-of-field.
- All metal, dual micro solenoid, electronically operated vertical travel shutter. Precisely accurate stepless programmed shutter with speeds from 1/30 second to 1/1000 second.
- Self timer glows in ever faster series of red light “blinks” before shutter trips in ten seconds. May be cancelled by touching shutter release.
- Positive film advance indicator confirms that film is actually being advanced. As film is wound a dotted line, in wave form, is visible in a small window next to the eyepiece of the FP-1.
- Professional system accessories and full line of Konica Hexanon Lenses available.

Konica FP-1

35mm slr camera

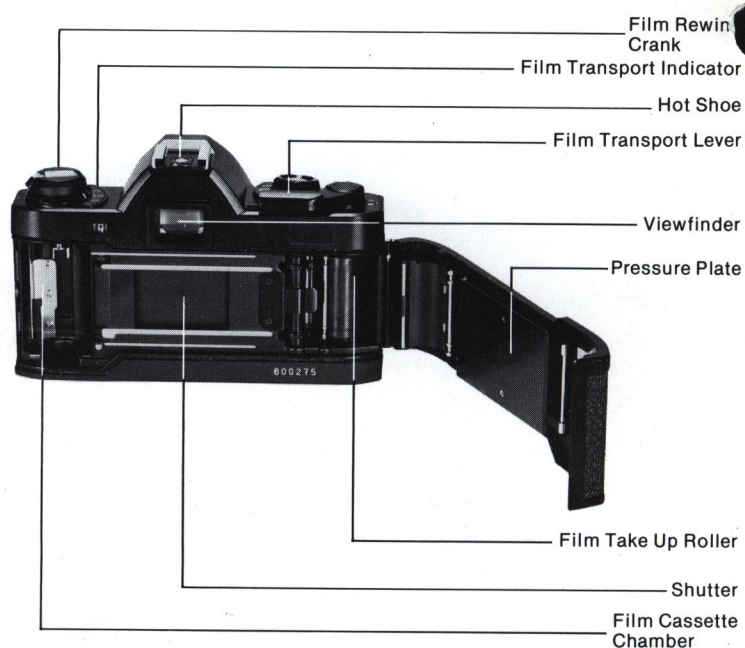
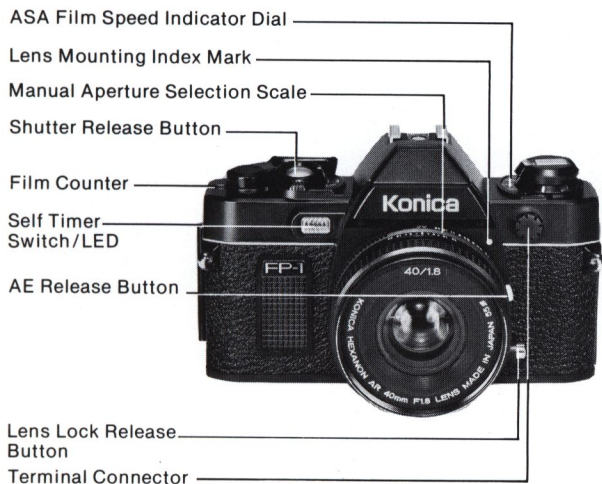

Technical Specifications

Type 35mm focal plane shutter TTL-AE single lens reflex.
Format 24 x 36mm full frame 35mm.
Standard Lens Options Konica Auto Hexanon Lenses —
 40mm f1.8, 50mm f1.7, 50mm f1.4, 57mm f1.2.
Lens Mount Konica Bayonet II (47mm diameter).
Flange/Film Distance 40.5mm
Shutter Vertical travel, metallic.
 Electronic with dual micro solenoids computer controlled.
Shutter Speeds 1/30 to 1/1000 second.
Flash Synth Built-in hot shoe. Shutter automatically
 set to 1/100 second with dedicated
 electronic flash. Manually set at
 1/100 second with other hot shoe type electronic flash.
Viewfinder Parallax-free, eye-level pentaprism.
 Accepts Konica slide-in eyepiece accessories.
Field of View in Finder vs. Film Image Area 90%
Magnification 0.66x with 40mm lens
 0.82x with 50mm lens
Viewfinder Information LED display readouts:
 • Green LED lights up for correct automatic exposure.
 • Red LED lights up for underexposure warning.
 • Green LED flickers when dedicated flash is ready to fire.
 • Red LED flickers when using lens in "manual" mode.
 • Green LED lights to show battery condition.
Focusing Screen Konica three way system with
 split image, microdiaphragm, and fine ground glass.
Light Meter Center weighted/CdS cell.
 Thru-the-lens (TTL) metering system.
AE Coupling Range ASA 100
 EV8 (at 1/30 sec. with f2.8) to EV 17 (at 1/1000 sec. with f11)
Exposure Control Shutter speed priority system.
 Fully automatic, thru-the-lens, full opened aperture
 metering. Optimum shutter speed and aperture
 combination automatically selected.

Film Speed Range ASA 25 - 800
Shutter Release Soft touch release with dual microswitch
 First 0.7mm travel for light metering LED display
 and battery check. Additional 0.4mm to release shutter.
Film Loading Konica auto film load system.
Film Transport Single stroke lever automatically
 advances film, winds shutter, counts exposures
 and prevents unwanted double exposures.
 Automatic film transport with optional Konica Autowinder F.
Film Transport Indicator Positive visual indicator
 confirms film transport.
Film Rewind Rapid rewind crank system
Frame Counter Oversize window with additive counter.
 Auto start to Number 1. Automatic zero reset.
Reflex Mirror Oversize, coated mirror prevents image
 cutoff in finder even with bellows extension at
 1:1 magnification. Mirror design permits automatic
 operation even with extreme wide angle lenses. Instant
 return mirror action prevents image blackout after exposure.
Self Timer Digital control electronic self timer with
 10 second delay and blinking LED display.
Power Source One (1) 6V Alkaline 4LR-44 battery.
 (Eveready 544, Mallory PX28 or equivalent)
Tripod Socket Standard 1/4" x 20.
Dimensions Body only - 5.5" x 3.5" x 1.7"
 (140mm x 89mm x 45mm)
 With 40mm f1.8 lens - 5.5" x 3.5" x 2.8"
 (140mm x 89mm x 72mm)
 With 50mm f1.7 lens - 5.5" x 3.5" x 3.3"
 (140mm x 89mm x 85mm)
Weight Body only - 17.5 oz. (495g)
 With 40mm f1.8 - 22.4 oz. (635g)
 With 50mm f1.7 - 24.8 oz. (705g)

Specifications subject to change without notice