

Mamiya M645 SUPER



Interchangeable film back system

**The most versatile AE-Prism finder
in three way mode metering**

*** Average (A), Spot (S) and Auto shift
(Auto A-S)**

**Automatic film advance with
power drive N**











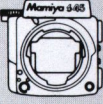

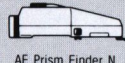
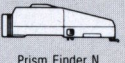



**Extensive system of interchangeable
lenses**





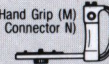















MAMIYA AMERICA CORPORATION











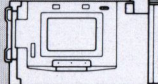





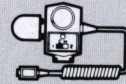

8 Westchester Plaza, Elmsford, NY 10523
Phone: (914) 347-3300 • Fax: (914) 347-3309







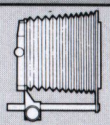
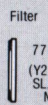
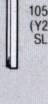



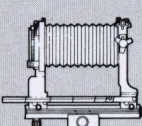

Mamiya M645 SUPER SYSTEM

| Body | Winding-up Equipments | Finder Equipments | Grip and Tripod Adapters |
|--|--|--|--|
|  <p>M645 Super camera body</p> |  <p>Wind-up Crank N-2</p>  <p>Power Drive N (with Wrist Strap)</p> |  <p>AE Prism Finder N</p>  <p>Prism Finder N</p>  <p>Waist Level Finder N</p>  <p>Angle Finder N</p>  <p>Magnifier N</p> <p>Eye Correction Lens N for Prism/AE Prism Finder N +3, +2, +1, -1, -2, -3 diopter</p>  <p>Type A (Matte)</p>  <p>Type A4 (Checker)</p>  <p>Type B (Rangefinder Spot)</p> <p>Focusing Screen N</p>  <p>Type C (Microprism)</p>  <p>Type E (Rangefinder Spot/Microprism)</p> <p>Diopter Lens for Waist Level Finder +2, +1, 0, -1.5, -2, -3 diopter</p> |  <p>Left Hand Grip (S) (with Connector N)</p>  <p>Quick-Shoe Model 2</p>  <p>Left Hand Grip (M) (with Connector N)</p>  <p>External Battery Case</p>  <p>Left Hand Grip (L) (with Connector N)</p>  <p>Tripod Adapter Model 2 for Polaroid Land Pack Film Holder N</p> |

Lenses

| Wide-angle Lenses | Standard Lenses | Telephoto Lenses | Zoom Lenses | Special Effect Lenses |
|--|---|--|--|---|
|  <p>35mm f/3.5 N</p>  <p>45mm f/2.8 N</p>  <p>55mm f/2.8 N</p> |  <p>70mm f/2.8 (Lens-Shutter type)</p>  <p>80mm f/1.9N</p>  <p>80mm f/2.8 N</p>  <p>110mm f/2.8 N</p> |  <p>150mm f/3.5 N</p>  <p>210mm f/4 N</p>  <p>300mm f/5.6N ULD</p>  <p>500mm f/5.6</p> |  <p>55-110mm f/4.5 N Zoom</p>  <p>105-210mm f/4.5 ULD Zoom</p> |  <p>24mm f/4 ULD Fisheye</p>  <p>50mm f/4 Shift</p>  <p>80mm f/4N Macro</p>  <p>145mm f/4 Soft Focus</p>  <p>2X Tele-Converter N</p> |

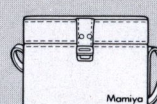
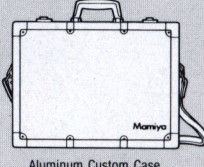
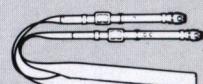
| Film Holder Equipments | Remote Control Equipments | Hood/Filters |
|---|--|--|
|  <p>120 Roll Film Holder N</p>  <p>Polaroid Land Pack Film Holder N</p>  <p>220 Roll Film Holder N</p>  <p>120 Roll Film Insert</p>  <p>220 Roll Film Insert</p>  <p>135 Roll Film Holder N</p>  <p>135 Roll Film Insert N</p> |  <p>Receiver MZ</p>  <p>Transmitter MZ</p>  <p>Cable Release Adapter</p>  <p>Connector N</p> | <p>Lens Hood</p>  <p>for 45mm f/2.8 N</p>  <p>for 55-110mm f/4.5 N Zoom</p>  <p>for 70mm f/2.8</p>  <p>for 55mm f/2.8 N</p>  <p>for 80mm f/2.8N and 110mm f/2.8N</p>  <p>for 80mm f/1.9N</p>  <p>Bellows Lens Hood</p>  <p>Filter 77 φ (Y2, YG, O2, UV, SL, 81C, 82C, ND16, PL)</p>  <p>Filter 105 φ (Y2, YG, O2, UV, SL, R1)</p>  <p>Focusing Handle</p> |

| Close-up/Copy Equipments | Trunk | Strap/Camera Case |
|---|---|---|
| <p>Auto Extension Rings</p>  <p>No. 1</p>  <p>No. 2</p>  <p>No. 3-S</p>  <p>Auto Bellows N (with Double Cable Release)</p>  <p>Auto Macro Spacer</p>  <p>Balloon Bellows</p>  <p>Slide Copy Attachment</p> <p>Reversing Ring</p>  <p>RS-58</p>  <p>RS-67</p> <p>Connecting Ring</p>  <p>CN-58</p>  <p>CN-67</p> |  <p>Compartment Case</p>  <p>Aluminum Custom Case</p> |  <p>Strap N</p>  <p>Camera Semi Soft Case N</p> |

MAMIYA M645 SUPER MAIN SPECIFICATION

Camera Type — 6 × 4.5cm format, electronically controlled focal-plane shutter, Single Lens Reflex

Film Type — 120 roll film (15 exposures), 220 roll film (30 exposures) 6 × 4.5cm format, Polaroid land pack film (100 & 660 Series), 135 roll film (36, 24, 12 exposures)

Shutter Speed — B, 4-1/1000 sec. (quartz controlled) Mechanical shutter speed of 1/60 sec.

Interchangeable Focusing Screen — A total of five types of Focusing Screens

Battery Check — By Depressing B.C. button

Flash Synchronization — X (1/60 sec.)

Remote Control — Remote control capability by using the Power Drive N in combination with the Transmitter/Receiver MZ

Dimensions — 91mm × 87.5mm × 116mm (with 120 Roll Film Holder N)

Weight — 895g (with 120 Roll Film Holder N, and without battery)

*Specifications and appearance are subject to change without notice.