

# DIGITAL LENSES

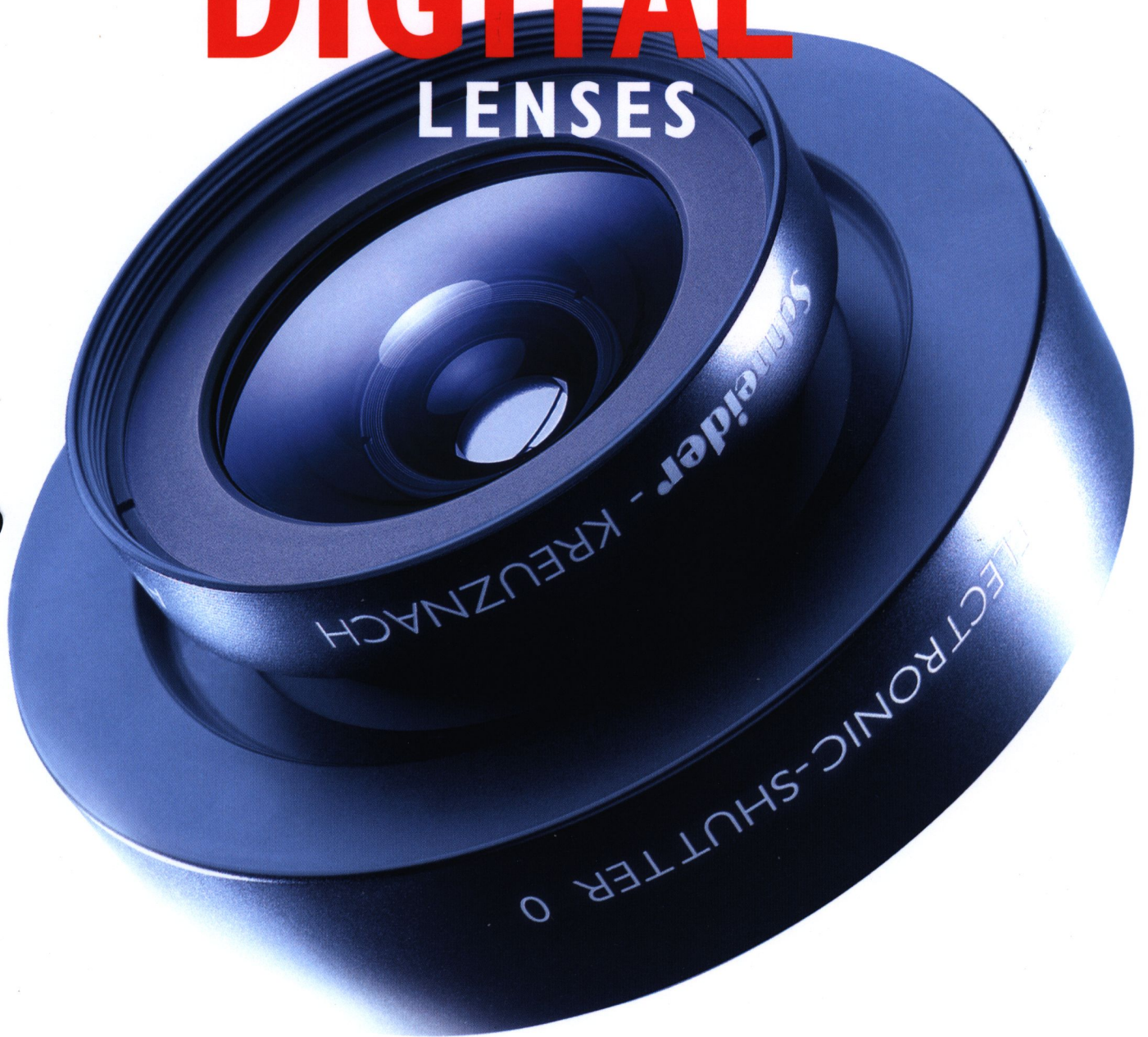





Computer-controlled manufacturing processes guarantee a constant high level of quality

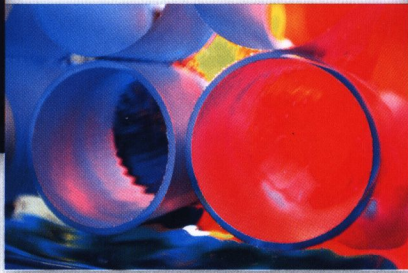

Only the best, optically homogeneous glasses are used for Schneider lenses



In ultra-modern vacuum coating facilities, a reflex-reducing layer is applied



## SCHNEIDER-KREUZNACH: The Reliable Partner of Professionals

High-quality optical photographic and reproduction systems are among the most complex products to manufacture. For that reason only a few manufacturers can maintain a position worldwide in this professional market. We are proud to be among them. SCHNEIDER-KREUZNACH has been synonymous with high-performance lenses of the highest quality for over 90 years.

The confidence that professionals worldwide have placed in lenses from SCHNEIDER-KREUZNACH is not based solely on the long tradition and almost legendary reputation of world-renowned lenses like the APO-SYMMAR, XENAR, SUPER-ANGULON or COMNON. SCHNEIDER-KREUZNACH combines extensive experience in lens construction with the most modern computational, design, manufacturing, and stringent testing methods which assure the highest level of quality which has become particularly evident in the new DIGITAR-series.

This begins with the creation of new products in close cooperation with experienced users, in order to find solutions which meet practical needs when judged by really relevant criteria. Then, in the design stage, the engineers have access to over 130 kinds of glass, and from this data they optimize lens systems with modern high-powered computers by means of elaborate calculations supported by computer-aided design. Countless prototypes are pro-

duced in order to demonstrate their potential in exacting testing and measurement procedures as well as in hard practical tests. Only when they meet all the required parameters of quality without limitation does mass production begin. In order to maintain the highest level of quality, very strict inspections are integrated into all production steps, such as grinding, polishing, coating, and centering. That applies equally for the manufacturing of the mounts and of other mechanical parts, up to and including the assembly of all the components into complete systems. And at the end of the process, before shipping, every single lens (not just random samples!) is subjected to a thorough test for quality and performance. The sole purpose of all these measures is to be able to offer lenses of the highest quality for photography, enlargement, and projection to the discriminating professional user.

Although production cycles in the area of electronics are becoming shorter and shorter, the users of lenses from SCHNEIDER-KREUZNACH in making their decision always expect long-term use, a condition which presupposes a quality at the highest level of technological achievement. SCHNEIDER-KREUZNACH has also adhered to this principle in connection with the expansion of its product line in the direction of digital image systems, so as to remain, not only today, but also in the future, a significant and reliable partner of the professional.



Strict inspections on all stages of production up to the final checkout guarantee that the lens will have the image quality defined by the previous computer simulation



Our Range of Products

(Some products may not be available in your country)



**Photo Optics**

Absolutely state of the art taking and enlarging lenses for all fields of application of professional analog and digital photography, from 35 mm to large format.

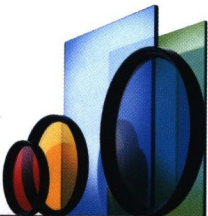

**B+W Filters**

The leading brand for demanding professionals and amateur photographers for creative imaging with optimal quality. Choose from correction and effect filters for color and black-and-white photography; Käsemann polarizing filters; close-up lenses; special-effect and trick lenses; filters with SLIM mounts for vignetting-free exposures with wide-angle zoom- and fixed focal length lenses.



**CCTV/Machine Vision/OEM**

Specialty lenses corrected for the infrared range, high-resolution C-mount lenses and macro systems for image processing and for non-contact measurement technology as well as customer-specified design and fabrication of optical and mechanical components.



**Cine Projection**

High-performance motion picture projection lenses for 16 mm, 35 mm and 70 mm films, anamorphic projection attachments, wide-angle projection lenses for 70 mm films with 8 or 10 perforations per frame, test films for 35 mm projection.



**Digital Projection**

New Cine-Digital line of projection lenses in a large variety of closely stepped fixed focal lengths for digital high-performance projectors and anamorphic attachments, with guaranteed high contrast and sharp detail rendition. Their fields of application range from digital cinemas to fixed installations in front and rear projection, all the way to rental and staging applications.

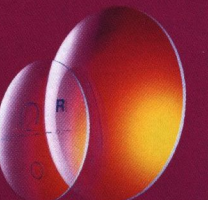

**Ophthalmic Optics**

Glass- and plastic lenses for eyeglasses; single- and multiple strength lenses, gradient lenses of high-refractive materials with special glass geometry for better appearance and greater wearing comfort.



**Servo Hydraulics**

Electro-hydraulic and electro-pneumatic servo valves with high-grade electronic control units for precise positioning-, speed-, power- and pressure adjustments in mechanical engineering.



# DIGITAL PHOTOGRAPHY ALSO NEEDS SHIFT,

## Special photography for professionals cannot do without perspective correction

One of the most important aspects of perfect professional special photography for advertising, architecture and industry is control of perspective. This seems to be the case for digital as well as for conven-

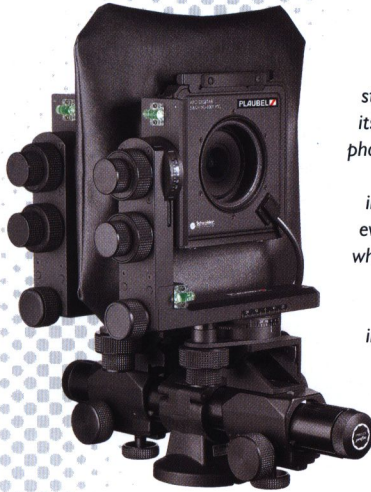

Digital photography with adjustable studio cameras has meanwhile become a standard feature not only in its own domain of catalogue photography but also in many other applications such as industrial, architectural and even landscape photography where short focal lengths are essential; the Apo-Digital lenses 5.6/24 and 5.6/35 in the Schneider Electronic-Shutter integrated in a recessed lens plate are the ideal wide angle lenses for these applications.

The newly developed Schneider Electronic Shutter 0 is so compact it can be inserted into recessed wide angle lens plates and it can be computer controlled via eyelike software.

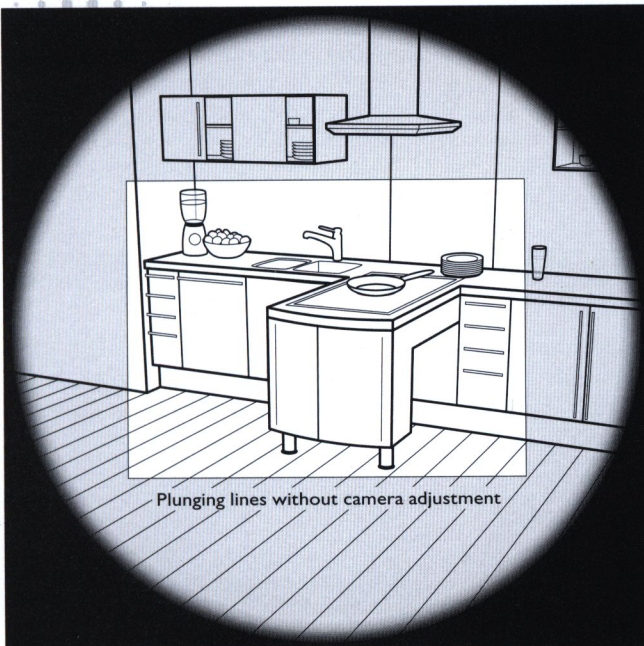

In professional digital photography studio pictures are the most important application. Because they are mainly taken diagonally from above fixed cameras will produce "plunging lines" if the image plane is not parallel with the object's vertical lines.

tional photography. Some of the adjustable cameras which have originally been designed for much larger formats have already been modified accordingly or supplemented by new versions to meet the special needs of smaller sensor formats.

As a result direct and indirect "parallel shifts" in order to control perspective are now possible even within digital photography.

Many photographers who are familiar with image processing programs, like for instance Photoshop®, know that trapezoidal distortions can be corrected, in other words "converging lines" can be straightened. They might be under the impression that camera adjustment is dispensable. But they are mistaken. Because adjusting on the computer does not result in correct proportions and reduces the quality of the picture: the photographer is unaware of the vertical compression in unadjusted pictures (data of many parameters would be needed for their calculation) which is particularly strong within the distant end of the object – i.e. the top end with pictured of tall buildings and the bottom end with top view pictures. So changing the trapezoid to the rectangle - verifiable on the basis of the parallelizing of originally converging (plunging) lines – alone is not the answer; the aspect ratio is still incorrect (the height may be up to about 20% smaller than it should be).

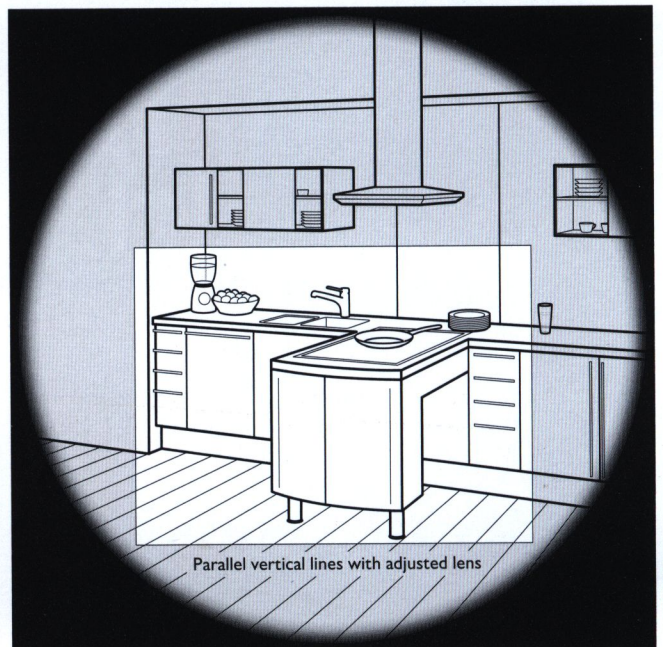

Direct or indirect parallel adjustment with an adjustable studio camera and a lens providing a large image circle enable to correct plunging lines and to re-establish correct proportions (identical scale top and bottom in height and width).



# TILT AND SWING

## Adjustment on the computer reduces sharpness and produces color fringes because of interpolation

In addition to this, corrections using Photoshop® requires that the pixels be recalculated. The inevitable result of interpolation causes a significant loss in sharpness and contrast of fine details. It also can produce reddish brown or blue fringes between high contrast structures especially along the edges between areas of varying brightness (i.e. object/background). Additionally, all algorithms used to reduce such color fringes will again result in loss of sharpness of focus.

On the other hand, if adjustment is dealt with during the process of taking the picture then one could not only save valuable time trying to adjust with image processing programs, but there would also be no loss of sharpness through interpolation and no disturbing color fringes. The photographer would be able to tell while focusing whether the position of the camera has to be changed in order to fit the object correctly adjusted into the picture. If you later notice while working on the computer that a perspective correction has produced two blank wedges along the edges of the picture (see illustration above) within the desired image area you will have no choice but to take the picture again.

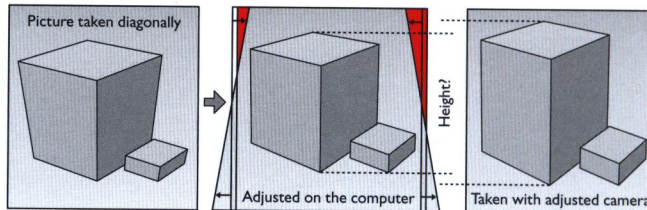

When adjusting a picture on the computer which has been taken with a fixed camera, the object will have to be changed into a trapezoid. Afterwards the picture will in turn have to be cut into a rectangle. The edges of the detail might get cut off in the process (see red). The picture would also have to be stretched lengthwise.

Almost all manufacturers have launched more compact adjustable studio cameras which have been adapted to the special requirements of digital photography



The new cameras allow a smaller lens to digital back distance for the use of shortest focal length wide-angle lenses



The very compact Schneider Electronic-Shutter is ideal for the new compact ...



... studio cameras because it is small enough to be installed in their recessed lens boards

The Digitar lenses can be combined with a helical focuser for the use with cameras without bellows like this scanner camera

## The fine rectangular pixel structure of the sensor demands special quality of the lens

SCHNEIDER digital lenses used together with adjustable studio cameras with high resolution digital backs guarantee the finest in quality: they offer optimal sharpness of focus making best use of high resolution CCD sensors, excellent contrast into the smallest detail for brilliant pictures, correction of distortion to the greatest possible extent and the best possible leveling of the image area taking into account the perfect evenness of the digital sensor, as well as the protection and filter glass directly in front of the sensor.

In addition, they also allow perspective control and tilting (depth of field control according to the Scheimpflug principle) while taking the picture because of their relatively large image circle – see illustration and chart on page 13 – which saves time and money as well as preventing loss of quality.





*Achim K. Rösch (Germany):  
“After all, breathtaking perspectives  
can be realized even on location”*



# WIDE-ANGLE AND MACRO

Apo-Digitar 5.6/24 XL, 5.6/35 XL, 5.6/47 XL, Digitar 2.8/28 L; Apo-Digitar 5.6/80 M, 5.6/120 M

## Finally genuine wide-angle lenses for digital photography with chip-back



The large image circle of the Apo-Digitar and Digitar wide-angle lenses enable dynamic shots for architecture, industry and advertising



With a chip size of for instance 24x36 mm both Apo-Digitare M lenses manage an object size of about 6x9 mm up to 10x15 cm

Up to now there were no genuine wide-angle focal lengths for view cameras with a chip digital backs because the digital chip formats are considerably smaller than the conventional film formats. The corresponding lenses for 35 mm cameras have no shutter and allow no camera adjustment because the image circle is usually only 43 mm. This is why we developed new wide-angle lenses. These meet high quality requirements concerning contrast and resolution, correction of distortion and absence of color fringes. At the same time, with an image circle of 60 to 110 mm they have capacity for adjustment, correction of perspective, "converging lines" as well as for depth of field control according to the Scheimpflug law as is to be expected of professional large format photography.

## Perfect images in the extreme close-up and macro range

Lenses designed for infinity lose sharpness and distort when applied to higher magnifications approaching 1:4 (or higher). The Apo-Digitar M lenses have been optimized for a 1:1 reproduction ratio, with excellent performance in the 1:4 to 4:1 range. This allows image quality at or beyond the limit of the performance of current high-resolution chip backs.

1

### The image circle grows with the scale

The image circles and angles of view on page 13 have been designed to guarantee the use of the full range of potential of the high-resolution digital backs. The perfect image quality of our lenses in resolution, contrast, absence of color fringes and distortions, etc. support this. The data relates to a working aperture of 11 (with larger apertures there is almost no loss of sharpness of image evident but only a very slight fall-off in illumination towards the edges) together with focusing at infinity and the relevant scale for macro lenses respectively. With a constant angle of view the image circle widens for shorter distances and larger scales respectively because of the longer pullout for a proportion corresponding with the scale, i.e. with a scale of 1:5 for a fifth. However, this does not apply to macro lenses at scales around 1:1, as diffraction increases rapidly with growing magnification scale as a result of the growing discrepancy between the effective aperture and the nominal aperture.

WIDE-ANGLE AND MACRO



5.6/24 XL  
Schneider Electronic Shutter 0



5.6/35 XL  
Schneider Electronic Shutter 0



2.8/28 L  
Schneider Electronic Shutter 0



5.6/47 XL  
Schneider Electronic Shutter 0



5.6/80 M  
Schneider Electronic Shutter 0



5.6/120 M  
Schneider Electronic Shutter 0





*Achim K. Rösch (Germany):  
"Perfect definition and contrast  
of the Apo-Digital lenses  
even at larger scales have convinced me"*





# MEDIUM AND LONG FOCAL LENGTHS

Apo-Digitar 4.0/60 N, 4.0/80 L, 4.5/90 N, 5.6/100 N, 5.6/120 N, 5.6/150 N, 5.6/180 T



The vast majority of product images are shot diagonally from above. This entails the need for extensive adjustment in order to correct the perspective totally or residually which can only be accomplished with lenses where the image circle is larger than the diagonal of the image format. The subsequent rectification on the computer with the help of image processing software has more than one disadvantage: Firstly it is much more time consuming than simply adjusting the camera beforehand. Secondly it warps the proportions (see page 5). Thirdly it reduces sharpness because of the interpolation resulting from the recalculation of the pixels, and last but not least this very interpolation is responsible for the creation of visible reddish brown or blue color fringes.

## For universal use with best possible sharpness and natural perspective

Advertising and catalogue production in studios are still the main application for adjustable cameras with high resolution digital backs. One-shot chip sensors have extended this field of employment to include moving objects, i.e. people for fashion shots. The SCHNEIDER Apo-Digitar N lenses offer the necessary focal lengths for a perfectly natural perspective. They offer an outstanding clarity and sharpness over their entire image circle, big enough to allow wide parallel shifts for perspective corrections of converging lines and lens tilts or swings for depth of field control according to Scheimpflug's rule.

The large range of closely staggered focal lengths for this series guarantees the most suitable lens for the angle of view and the image circle diameter for all the current sensor sizes. Their apochromatic correction reduces color fringing which has more significance for digital than for conventional photography on film because of the pixel structure and interpolation that both enhance existing color fringes. The meticulous flattening of the field curvature of this range of lenses does justice to the advantage of the perfectly plane sensor surface. The recommended distance ranges from infinity up to an image scale of 1:3. Sharpness is still fine even at higher scales but you will probably find the macro lenses Apo-Digitar M to be slightly superior.



## Strictly speaking the image circles are even larger

Some of these lenses actually have a larger image circle than specified on page 13. Because the quality decreases towards the edge – as it does with all lenses – full exploitation of the maximum range means that within those corners most distant from the optical axis reduced sharpness would limit the quality of the lens regardless of the resolution capacity of the sensor. Therefore we have specified smaller image circle diameters and angles of view as well as corresponding lens displacement values in the table which will guarantee the proverbial SCHNEIDER quality you expect. But it is good to know that should the background be beyond the depth of field anyway or should the concerning image corners be lacking in finely structured details as it is the case with blue skies, clouds, or homogeneous background carton, there is some more additional free room left for even larger parallel displacement (perspective control) and for tilt and swing (depth of field control according to Scheimpflug's rule).

STANDARD FOCAL LENGTHS



4.0/60 N  
Schneider Electronic Shutter 0



4.0/80 L  
Schneider Electronic Shutter 0



4.5/90 N  
Schneider Electronic Shutter 0



5.6/100 N  
Schneider Electronic Shutter 0



5.6/120 N  
Schneider Electronic Shutter 0



5.6/150 N  
Schneider Electronic Shutter 0



5.6/180 T  
Schneider Electronic Shutter 0



# TECHNICAL INFORMATION

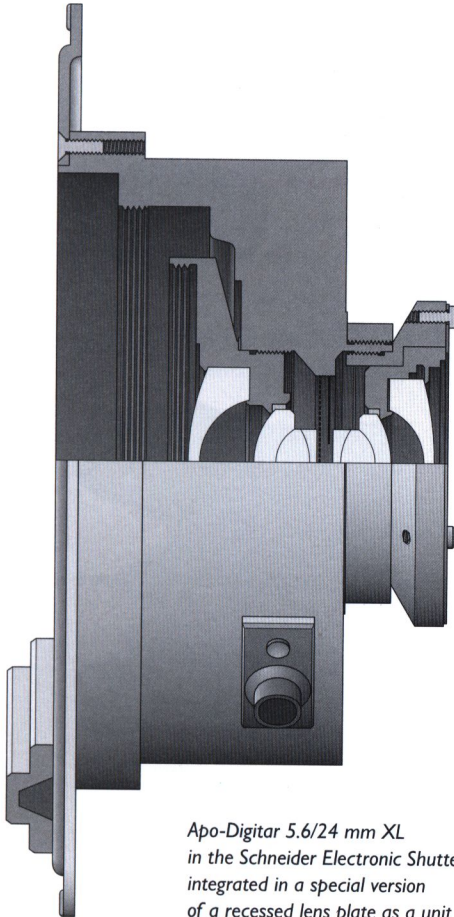

*Apo-Digitar 5.6/24 mm XL  
in the Schneider Electronic Shutter 0,  
integrated in a special version  
of a recessed lens plate as a unit*

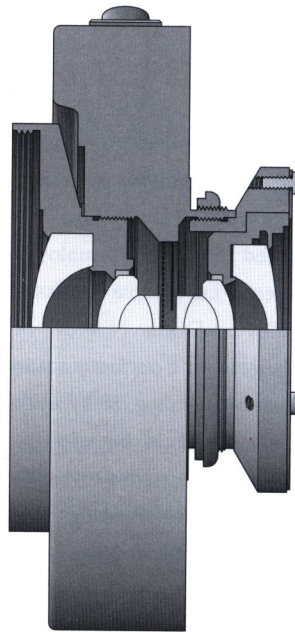

*Apo-Digitar 5.6/24 mm XL  
in the Schneider Electronic Shutter 0,  
only 80 mm in outer diameter*

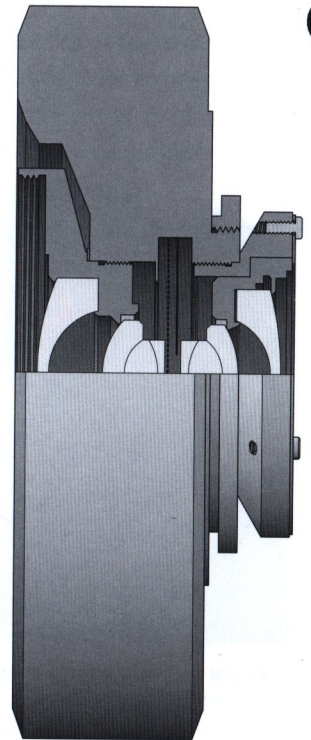

*Apo-Digitar 5.6/24 mm XL  
in the Rollei Electronic Shutter 0*

## New Schneider and Rollei Electronic Shutters enable easy control via computer software

Electronically controlled shutters have proven to be an advantage and are already an accepted standard for lenses of adjustable cameras with digital backs. They are easy to synchronize with the digital back and offer additional means of control, i.e. choice of time or aperture in much finer nuances. With the new Schneider Electronic Shutter this can be done directly from the computer. The data on the table on page 12 is for both the Schneider Electronic Shutter 0 and the Rollei Electronic Shutter 0.

**Schneider Electronic Shutter:** This is electronically controllable via the computer. Maximum opening is 23 mm (size 0). Shutter speeds B and 32 s up to 1/60 s in tenth-gradate. In one-tenth-stop increments adjustable 5-blade-iris aperture. Weight 180 g.

**Rollei Electronic Shutter:** This is electronically controllable via remote control Rollei LensControl S. Maximum opening is 24 mm (size 0). Shutter speeds B and 30 s up to 1/500 s in third-stop increments. In tenth-stop increments adjustable 5-blade-iris aperture. Weight 306 g.

## Conversion factors for the comparison of focal lengths with analog and digital image formats

The chosen image detail depends on the focal length of the lens as much as on the format. In order to receive the focal length necessary for a digital chip format which shows the same content as the familiar analog film format, the focal length for the analog film format has to be multiplied by the factor stated below for the respective digital format. Conversely one has to divide the focal length (digital) by the same format factor to calculate the corresponding focal length of the analog camera. Format factors for the comparison of square with non-square formats have been printed in gray.

is for	The format factor with the formats		
	24x36 mm	6x6/6x7 cm	4x5 in
24x36 mm	1.0	0.55 / 0.49	0.28
31x31 mm	1.0	0.55 / 0.50	0.29
37x37 mm	1.2	0.66 / 0.59	0.34
37x49 mm	1.41	0.77 / 0.69	0.40
63x63 mm	2.06	1.13 / 1.01	0.58



# SPECIFICATIONS

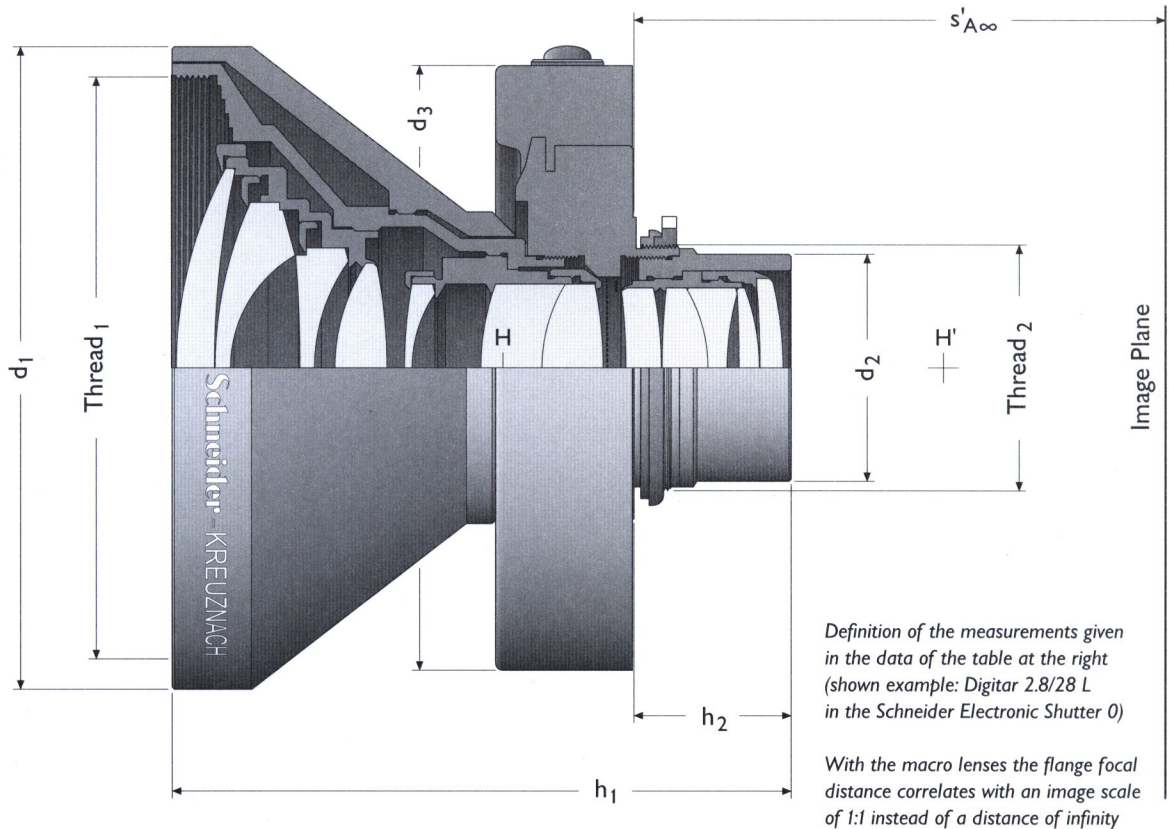

All lens sections are in actual size

## Filter effects cannot be fully replaced by image processing via software even for digital shots

Almost every image processing software provides you with a variety of manipulations for digital images including carefully directed changes in color or density. As a consequence, correction filters seem to be obsolete in digital photography – at the first glance. However, this is wrong. Most of all effects that can be achieved by filters in front of the taking lens can be simulated on the computer only as an approximation or even not at all. The reason is that all colors are available as discrete wave-lengths when the photo is captured so that at this stage a filter can influence the result according to its transmission curve. However, in the digital file these infinite number of wave-lengths is no longer available but only three discernible color values R (Red), G (Green) and B (Blue). The color enhancing and reflection reducing effects of polarizing filters cannot be digitally simulated, too. And even the effect of soft focus lenses which is independent from discrete or compound wave-lengths cannot be fully simulated as the fascinating “aura of light” must be digitally replaced by a simple “blur”.

## Only exactly coordinated centerfilters assure the full dynamic range right into the image corners

Centerfilters reduce the physically unavoidable loss of light around the edges which depends on the angle of view. Their diameter and gradation in density has to be exactly coordinated with the individual wide-angle lens. It is not only the angle of view which is crucial and which can certainly be identical for two different lenses, but the position of the filter within the mount of the lens relative to the object nodal point is also important. Therefore, for maximum effect of the centerfilter, it is not sufficient just to pick the matching thread diameter. The table on the right shows the optimal centerfilters with order numbers for *Digital* lenses with an angle of view from 100°.

Subsequent density and contrast improvement around the edges via software on the computer does not completely substitute the centerfilter. It cannot restore the signal-to-noise ratio which has been clearly affected by loss of dynamic.

In case an additional filter is needed, i.e. adjustment of color temperature, it is to be used in front of and not behind the centerfilter.



Optical and mechanical dimensions																
Lens name	Rel. aperture / focal length [mm]	Optical design [lens elements/groups]	Effective focal length $\pm 1\%$ [mm]	Nodal point separation [mm]	Front-side screw-in thread for filters and other accessories	Max. diameter of the front mount [mm]	Max. diameter of the rear mount [mm]	Total overall height [mm]	Shutter diameter [mm] without cable	Flange surface to rear edge of mount [mm]	Thread of the shutter for assembling on the lens plate	Flange focal distance [mm] for the given distance or scale	Smallest diaphragm aperture	Shutter type and shutter size (different shutters on request)	Weight with shutter indicated [grams]	Order number of the lens including shutter
STANDARD LENSES				HH'	Thread <sub>1</sub>	d <sub>1</sub>	d <sub>2</sub>	h <sub>1</sub>	d <sub>3</sub>	h <sub>2</sub>	Thread <sub>2</sub>	s' <sub>A∞</sub>				
Apo-Digitar	5.6/24 XL	8/4	24.9	12.7	<sup>1)</sup> M 52 x 0.75 M 52 x 0.75	<sup>2)</sup> 54.0 54.0	43.0 43.0	<sup>2)</sup> 37.8 37.8	<sup>2)</sup> 80.0 97.0	<sup>2)</sup> 14.4 12.2	<sup>2)</sup> M 32.5 x 0.5 M 39 x 0.75	<sup>2)</sup> 26.4 24.2	16 16	Schneider Electr. 0 <sup>2)</sup> Schneider Electr. 0 Rollei Electronic 0	<sup>2)</sup> 255 380	<sup>3)</sup> 10427 10439
Digitar	2.8/28 L	12/10	29.3	58.0	M 77 x 0.75	85.0	30.0	81.1	80.0 97.0	20.6 18.4	M 32.5 x 0.5 M 39 x 0.75	69.9 67.7	22 22	Schneider Electr. 0 Rollei Electronic 0	535 660	17529 27631
Apo-Digitar	5.6/35 XL	8/4	36.4	15.4	<sup>1)</sup> M 52 x 0.75 M 52 x 0.75	<sup>2)</sup> 54.0 54.0	43.0 43.0	<sup>2)</sup> 44.2 44.2	<sup>2)</sup> 80.0 97.0	<sup>2)</sup> 17.0 14.8	<sup>2)</sup> M 32.5 x 0.5 M 39 x 0.75	<sup>2)</sup> 39.6 37.4	22 22	Schneider Electr. 0 <sup>2)</sup> Schneider Electr. 0 Rollei Electronic 0	<sup>2)</sup> 240 405	<sup>3)</sup> 10647 10649
Apo-Digitar	5.6/47 XL	8/4	47.6	20.8	M 52 x 0.75	54.0	43.0	54.7	80.0 97.0	22.0 19.8	M 32.5 x 0.5 M 39 x 0.75	52.3 50.1	32 32	Schneider Electr. 0 Rollei Electronic 0	300 425	17691 27632
Apo-Digitar	4.0/60 N	6/4	59.9	-1.9	M 40.5 x 0.5	42.0	31.0	42.5	80.0 97.0	15.0 12.8	M 32.5 x 0.5 M 39 x 0.75	55.1 52.9	22 22	Schneider Electr. 0 Rollei Electronic 0	250 375	17721 27637
Apo-Digitar	4.0/80 L	6/4	80.3	-1.8	M 40.5 x 0.5	42.0	31.0	42.6	80.0 97.0	14.6 12.4	M 32.5 x 0.5 M 39 x 0.75	78.8 76.6	32 32	Schneider Electr. 0 Rollei Electronic 0	255 380	17731 27638
Apo-Digitar	4.5/90 N	6/4	90.7	-3.5	M 40.5 x 0.5	42.0	34.0	48.7	80.0 97.0	20.7 18.5	M 32.5 x 0.5 M 39 x 0.75	86.8 84.6	32 32	Schneider Electr. 0 Rollei Electronic 0	280 405	17780 27728
Apo-Digitar	5.6/100 N	6/4	101.0	-2.1	M 40.5 x 0.5	42.0	36.0	42.3	80.0 97.0	15.7 13.5	M 32.5 x 0.5 M 39 x 0.75	97.0 94.8	45 45	Schneider Electr. 0 Rollei Electronic 0	250 375	17890 27729
Apo-Digitar	5.6/120 N	6/4	124.9	-2.4	M 40.5 x 0.5	42.0	42.0	41.8	80.0 97.0	17.3 15.1	M 32.5 x 0.5 M 39 x 0.75	120.1 117.9	64 64	Schneider Electr. 0 Rollei Electronic 0	255 380	17900 27731
Apo-Digitar	5.6/150 N	6/4	151.3	-4.6	M 40.5 x 0.5	42.0	45.0	71.2	80.0 97.0	37.8 35.6	M 32.5 x 0.5 M 39 x 0.75	151.4 149.2	64 64	Schneider Electr. 0 Rollei Electronic 0	395 520	17941 27792
Apo-Digitar	5.6/180 N	6/4	180.1	-3.6	M 55 x 0.75	58.0	42.0	65.0	80.0 97.0	24.5 22.3	M 32.5 x 0.5 M 39 x 0.75	173.2 171.0	64 64	Schneider Electr. 0 Rollei Electronic 0	343 508	1003283 1003284
Apo-Digitar	6.8/210 N 5.6/210 N	6/4 6/4	210.1 210.1	-4.2 -4.2	In preparation				80.0 97.0	M 32.5 x 0.5 M 39 x 0.75	64 64	Schneider Electr. 0 Rollei Electronic 1				
MACRO LENSES				HH'	Thread <sub>1</sub>	d <sub>1</sub>	d <sub>2</sub>	h <sub>1</sub>	d <sub>3</sub>	h <sub>2</sub>	Thread <sub>2</sub>	s' <sub>A:1</sub>				
Apo-Digitar	5.6/80 M	6/4	81.5	-1.0	M 40.5 x 0.5	42.0	31.0	47.9	80.0 97.0	19.9 17.7	M 32.5 x 0.5 M 39 x 0.75	159.7 157.5	32 32	Schneider Electr. 0 Rollei Electronic 0	275 400	17942 27639
Apo-Digitar	5.6/120 M	8/4	119.9	-1.6	M 40.5 x 0.5	42.0	37.5	55.1	80.0 97.0	23.2 21.0	M 32.5 x 0.5 M 39 x 0.75	236.1 233.9	45 45	Schneider Electr. 0 Rollei Electronic 0	300 425	17964 27732

Centerfilters for Digitar lenses						
Lens name	Rel. aperture / focal length [mm]	Centerfilter identification	Exposure correction as filter factor / in f-stops	Centerfilter thread (to be mounted at lens)	Front-side screw-in thread (for an additional filter)	Order number of the centerfilter
Apo-Digitar	5.6/24 XL	11d	4x / 2	M 52 x 0.75	M 72 x 0.75	19786
	For thread in lens plate *	11b	4x / 2	M 67 x 0.75	M 72 x 0.75	24061
Apo-Digitar	5.6/35 XL	11f	4x / 2	M 52 x 0.75	M 72 x 0.75	1003286
	For thread in lens plate *	11g	4x / 2	M 67 x 0.75	M 72 x 0.75	20241
Apo-Digitar	5.6/47 XL	11	3x / 1.5	M 52 x 0.75	M 67 x 0.75	16190

- Footnotes:**
- <sup>1)</sup> M 67 x 0.75 in the lens plate and M 52 x 0.75 in the lens
  - <sup>2)</sup> These measurements do not apply for versions where the Schneider Electronic Shutters are part of a special lens plate and both come as a unit (see illustration on page 10, top left).
  - <sup>3)</sup> Order number for this version:  

<b>5.6/24 XL</b>	<b>5.6/35 XL</b>	for camera system
10920	1003311	Arca Swiss
11419	1003313	Cambo
11394	1003312	Horseman
10470	1003309	Linhof M 679 / M 679 cc / M 679 cs
10453	1003308	Plaubel PL/2
10602	1003310	Sinar P2

**NOTE:** With the **Gaussoptic** program for Windows 3.xx/NT, versatile optical imaging calculations are possible. It contains all necessary Gauss lens data of the complete series of lenses for analog and digital photography that we supply.

The program **Gaussoptic** can be purchased directly from us under Order No. 43590 (our address can be found on the last page).

\* For application acc. footnotes <sup>2)</sup> and <sup>3)</sup> on the right and illustration on page 10, top left



Angle of view, image circles, range of lens displacements								Maximum lens displacements at f/11 and landscape format (for portrait format swap the data) focusing at infinity (standard lenses) or at scale 1:1 (macro lenses)											
Lens name	Rel. aperture / focal length [mm]	Recommended centerfilter type	Recommended aperture range	Angle of view at full aperture [degrees]	Image circle diameter [mm] at full aperture	Angle of view at f/11 [degrees]	Image circle diameter [mm] at f/11	24x36 mm		31x31 mm		37x37 mm		36x48 mm		37x49 mm		63x63 mm	
								vertical [mm]	horizontal [mm]	vertical [mm]	horizontal [mm]	vertical [mm]	horizontal [mm]	vertical [mm]	horizontal [mm]	vertical [mm]	horizontal [mm]	vertical [mm]	horizontal [mm]
<b>STANDARD LENSES</b>								24x36 mm		31x31 mm		37x37 mm		36x48 mm		37x49 mm		63x63 mm	
Apo-Digitar	5.6/24 XL	l1d	5.6-11	100°	60	100°	60	↑ 12 → 9.5	↑ 10 → 10	↑ 5.1 → 5.1	↑ 0 → 0								
Digitar	2.8/28 L		2.8-11	92°	60	92°	60	↑ 12 → 9.5	↑ 10 → 10	↑ 5.1 → 5.1	↑ 0 → 0								
Apo-Digitar	5.6/35 XL	l1f	5.6-11	88°	70	102°	90	↑ 29 → 25	↑ 27 → 27	↑ 23 → 23	↑ 20 → 17	↑ 19 → 17	↑ 0.6 → 0.6						
Apo-Digitar	5.6/47 XL	l1	8 - 11	92°	98	100°	113	↑ 42 → 37	↑ 39 → 39	↑ 35 → 35	↑ 33 → 30	↑ 32 → 29	↑ 15 → 15						
Apo-Digitar	4.0/60 N		4 - 11	53°	60	53°	60	↑ 12 → 9.5	↑ 10 → 10	↑ 5.1 → 5.1	↑ 0 → 0								
Apo-Digitar	4.0/80 L		5.6-11	53°	80	59°	90	↑ 29 → 25	↑ 27 → 27	↑ 23 → 23	↑ 20 → 17	↑ 19 → 17	↑ 0.6 → 0.6						
Apo-Digitar	4.5/90 N		4.5-11	53°	90	53°	90	↑ 29 → 25	↑ 27 → 27	↑ 23 → 23	↑ 20 → 17	↑ 19 → 17	↑ 0.6 → 0.6						
Apo-Digitar	5.6/100 N		5.6-11	53°	100	53°	100	↑ 35 → 31	↑ 32 → 32	↑ 28 → 28	↑ 26 → 23	↑ 25 → 22	↑ 7.3 → 7.3						
Apo-Digitar	5.6/120 N		5.6-11	48°	110	48°	110	↑ 40 → 36	↑ 37 → 37	↑ 33 → 33	↑ 31 → 28	↑ 31 → 27	↑ 14 → 14						
Apo-Digitar	5.6/150 N		5.6-11	40°	110	40°	110	↑ 40 → 36	↑ 37 → 37	↑ 33 → 33	↑ 31 → 28	↑ 31 → 27	↑ 14 → 14						
Apo-Digitar	5.6/180 T		5.6-11	37°	120	37°	120	↑ 45 → 41	↑ 42 → 42	↑ 39 → 39	↑ 37 → 33	↑ 36 → 33	↑ 20 → 20						
Apo-Digitar	6.8/210 T 5.6/210 T		5.6-11	32°	120	32°	120	↑ 45 → 41	↑ 42 → 42	↑ 39 → 39	↑ 37 → 33	↑ 36 → 33	↑ 20 → 20						
<b>MACRO LENSES</b>								24x36 mm		31x31 mm		37x37 mm		36x48 mm		37x49 mm		63x63 mm	
Apo-Digitar	5.6/80 M	1:4	5.6-11			40°	75	↑ 21 → 18	↑ 19 → 19	↑ 14 → 14	↑ 11 → 8.9	↑ 9.9 → 8.1							
		1:2	5.6-11			36°	80	↑ 24 → 20	↑ 22 → 22	↑ 17 → 17	↑ 14 → 12	↑ 13 → 11							
At scales exceeding 1:1 the lens should not be stopped down because of increasing diffraction		1:1	5.6 - 8	28°	80	28°	80	↑ 24 → 20	↑ 22 → 22	↑ 17 → 17	↑ 14 → 12	↑ 13 → 11							
		2:1	5.6	18.6°	80			↑ 24 → 20	↑ 22 → 22	↑ 17 → 17	↑ 14 → 12	↑ 13 → 11							
		4:1	5.6	12.6°	90			↑ 29 → 25	↑ 27 → 27	↑ 23 → 23	↑ 20 → 17	↑ 19 → 17	↑ 0.6 → 0.6						
Apo-Digitar	5.6/120 M	1:4	5.6-11			30°	80	↑ 24 → 20	↑ 22 → 22	↑ 17 → 17	↑ 14 → 12	↑ 13 → 11							
		1:2	5.6-11			28°	90	↑ 29 → 25	↑ 27 → 27	↑ 23 → 23	↑ 20 → 17	↑ 19 → 17	↑ 0.6 → 0.6						
At scales exceeding 1:1 the lens should not be stopped down because of increasing diffraction		1:1	5.6 - 8	26°	110	26°	110	↑ 40 → 36	↑ 37 → 37	↑ 33 → 33	↑ 31 → 28	↑ 31 → 27	↑ 14 → 14						
		2:1	5.6	17.4°	110			↑ 40 → 36	↑ 37 → 37	↑ 33 → 33	↑ 31 → 28	↑ 31 → 27	↑ 14 → 14						
		4:1	5.6	10.5°	110			↑ 40 → 36	↑ 37 → 37	↑ 33 → 33	↑ 31 → 28	↑ 31 → 27	↑ 14 → 14						

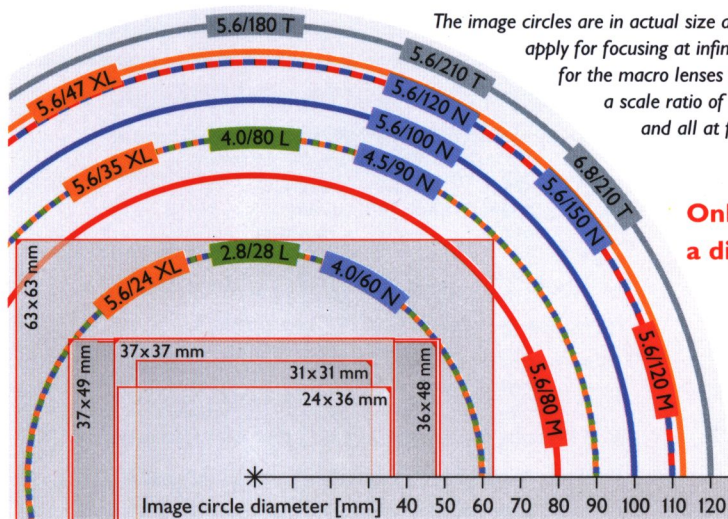

The image circles are in actual size and apply for focusing at infinity, for the macro lenses for a scale ratio of 1:1, and all at f/11

## IMAGE CIRCLES

Only sufficient reserve displacement guarantees a digital image with a correct perspective

The comparison of the chip formats with the image circles of the Digitar series shows that these leave a lot of scope within the focal lengths typical for this format for parallel displacement in order to correct perspective (elimination of converging lines) and for lens tilt/swing for a better control of depth of field.





Jos. Schneider Optische Werke GmbH  
Business unit: Photo Optics  
Ringstr. 132 · D-55543 Bad Kreuznach  
Phone: +49-(0)671-60 12 82  
Fax: +49-(0)671-60 11 08  
foto@schneiderkreuznach.com  
www.schneiderkreuznach.com