

Mamiya

RZ67

PROFESSIONAL IID



The World Class Reliability and Performance you've grown to respect... The Digital Evolution you've been expecting

The RZ67 Professional IID is a complete camera system with many world-class standards that just got better. From its legendary 6×7cm "Ideal Format", perfect for making 8×10 proportional enlargements with no image cropping or format waste, to its unique revolving film back, which provides vertical or horizontal composing, the RZ67 has earned the respect of professional photographers around the world.

Now with the demand from photographers to provide clients with the same quality and performance that they have come to expect, Mamiya introduces the new RZ67 Pro IID. The New RZ67 Pro IID is the result of an evolution into the next generation film and digital medium format camera. It offers advanced microprocessor technology for traditional film capture, while also enabling direct communication of all camera functions to digital capture backs through its MSC (Mamiya Serial Communication) system.

Offering the professional photographer the same exclusive features of its legendary predecessors such as:

Rack and pinion bellows focusing, with left and right coarse and fine focusing adjustment knobs plus a locking focus lever. Bellows focusing system that when fully extended provides macro focusing capabilities as well as infinity focusing for aerial photography when fully compressed. Interchangeable Mamiya world-class quality lenses, with built-in leaf shutters offer shutter speeds from 8 to 1/400sec. Electronic flash synchronization is achieved at all shutter speeds and intermediate shutter speeds can be set on the camera's speed dial setting for more critical digital exposure control.

The Interchangeable AE Prism Finder FE701 offers three metering modes, and provides A/S Matrix metering, 1/6 f/stops exposure accuracy plus an LED function display in the viewfinder.

The Interchangeable film holder, featuring twin film counters ensures easy visibility in both horizontal and vertical film back position. An improved film flatness system maximizes edge-to-edge sharpness for even greater image quality.

Many fail-safe system checks, warn the photographer both with visual and audible warning alert signals. And as you would expect, the new RZ67 Pro IID is system compatible with all existing RZ and RB lenses and most accessories.

These desirable and unique features combined with the sophistication of MSC technology makes the new RZ67 Pro IID the most versatile, reliable and desirable professional choice.





Interchangeable Film and Digital back system

With the interchangeable film and digital back system, you can shoot the same subject using color or black and white film, transparency film or digital capture.

The RZ67 Pro ID film back contains a built-in ISO film speed setting dial, dark slide warning and locks to prevent accidental film back removal. In addition, the camera body incorporates Mamiya's MSC (Mamiya Serial Communication) system enabling seamless data communication between the camera and digital back.



Fisheye Z37mm F/4.5W



120 Roll film holder HA703
220 Roll film holder HB702

Exclusive film backs for respectively 6x7 format (actual film image area 56x69.5mm) 120 and 220 roll films.

10 exposures for a 120 roll film
20 exposures for a 220 roll film.

6x4.5 120 Roll film holder HA704
(with special finder mask)

Exclusive film back for 6x4.5 format (actual film image area 56x41.5mm) 120 roll films.
Great for portrait shoots. Provides 15 exposures on a 120 roll.

Polaroid land pack film back HP702

The Polaroid land film back offers instant proofing for lighting and composition evaluation. Image size 7x7cm (actual film image area 69.5x69.5mm).

Interchangeable Film Holders

The RZ67 Pro IID accepts 6x7cm 120/220 roll film backs, a 120 6x4.5 film back and a Polaroid instant film back. Changing film types, film formats or a film back to a digital back is quick and easy.

Digital Back communication system for ultimate control

The RZ67 Professional IID offers advanced microprocessor technology for traditional film capture, while enabling MSC (Mamiya Serial Communication) of all camera functions from the camera to the digital capture back. Utilizing the same camera body for film and digital capture offers the greatest flexibility for any photographic application. (Please inquire for compatible digital backs).

Digital Back Adapter HX701



(to be available)

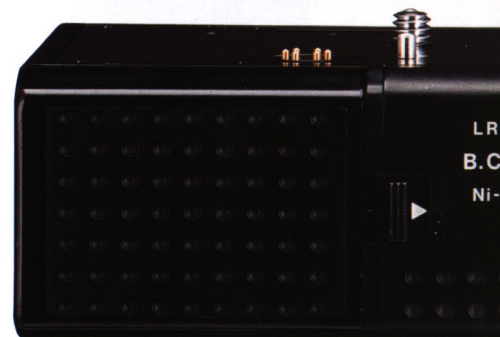

Interchangeable Lens System , Viewfinders and Power winder

The RZ67 Pro IID modular component system makes this camera the most useful and flexible imaging tool for the professional. A wide selection of interchangeable lenses from extreme wide angle to telephoto plus special purpose lenses offers the pro focal lengths for every shooting assignment. Interchangeable viewfinders for waist level or eye level viewing with or without a built-in exposure meter and interchangeable focusing screens provide the comfort and conveniences you would expect. Interchangeable film backs for different film formats, Polaroid instant film or digital capture backs increase the choices that professional photographers can offer their clients. Manual or motorized film advance and operation plus many useful accessories makes the RZ67 Pro IID the ideal image capture solution for their workflow today and tomorrow.

Interchangeable Viewfinders and Focusing Screens

The waist level Focusing Hood FW702 with self-erecting focusing hood and magnifier is included with each camera. The eye-level AE Prism Finder FE701 is an important accessory. It offers three-way metering (average, spot or auto shift) and computerized, aperture-priority shutter control, compatible with the RZ67 Professional IID's intermediate shutter speeds. It can also be operated manually.

Exposure compensation is adjustable within $\pm 3EV$; it also features an AE lock.

All RB67 viewfinders can be used for manual operation.

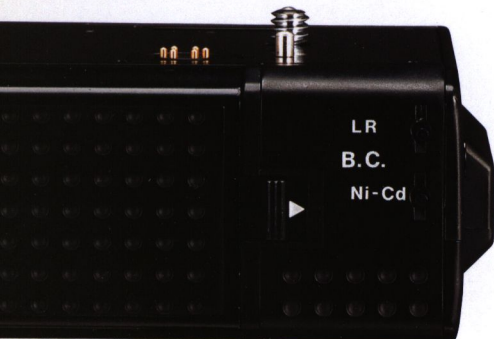
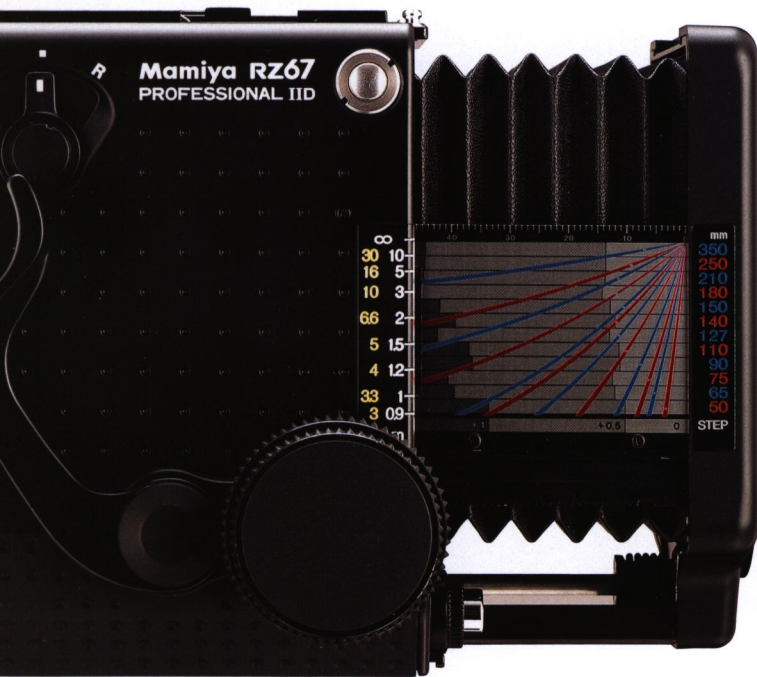
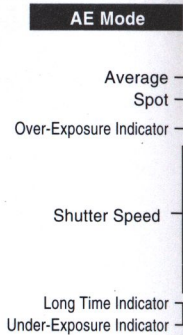

Interchangeable power winder

The Power Winder 2 is powered by AA batteries or an AC Adapter. It advances the film, cocks the shutter and resets the mirror automatically.

It produces single or sequential exposures at about 1 frame per second. It can be remote controlled with radio or infrared transmitters.



Manual Mode

- Red ±0.75EV-
- Orange ±0.25EV--0.75EV
- Green
- Orange -0.25EV--0.75EV
- Red -0.75EV-

World-Class Lenses For The RZ67 Professional IID

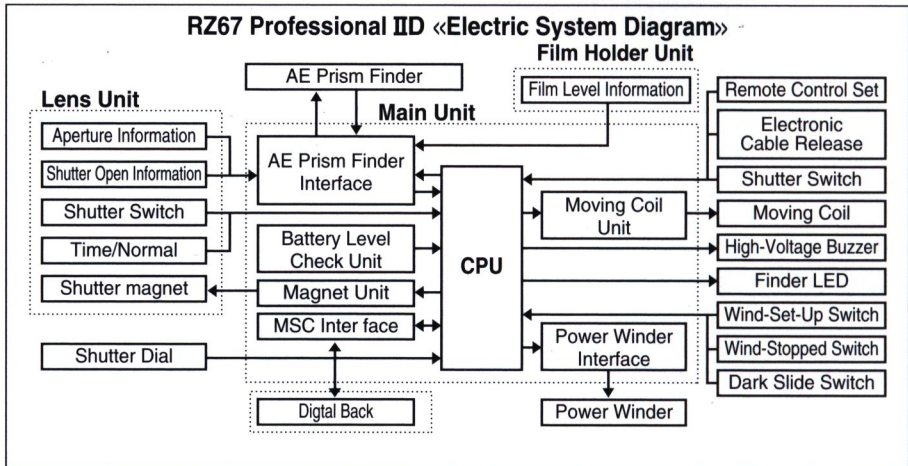
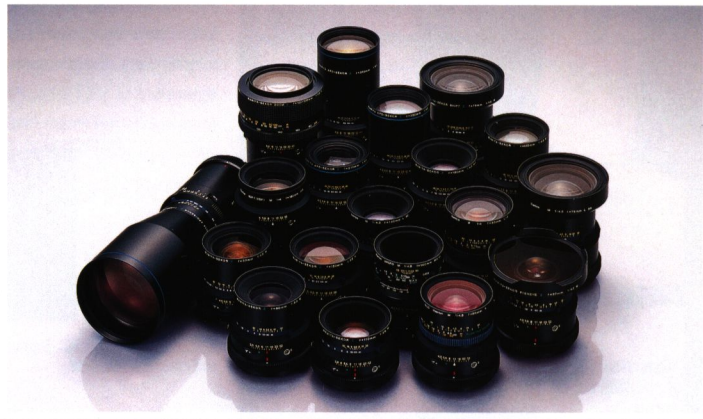

Electronic Interface

The ISO film speed dial is located on the film holders and interfaces electronically, through gold plated contacts, with the camera body, AE Prism Finder and RZ lenses. You set the dial when you load the film and never have to worry about correct exposure meter indexing.
(Electronic data functions are not available when using RB67 lenses.)



Body / Film Holder and Lens Interface

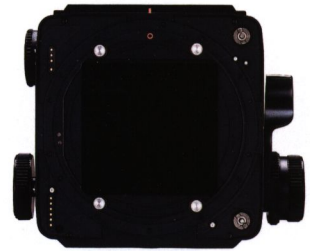

Camera body contacts from right to left

- | | | |
|---------------------------------|---------------------------------|--------------------------------|
| ① Aperture Information | ⑤ X Synch | ⑨ Ground Contact |
| ② Shutter Contact | ⑥ Shutter Speed Control Contact | ⑩ Shutter Open Contact |
| ③ Shutter Contact | ⑦ Time Switch Contact (normal) | ⑪ Time Switch Contact (common) |
| ④ Shutter Speed Control Contact | ⑧ Time switch Contact (Time) | ⑫ Aperture Information |

Camera body Contacts from Top to Bottom

- | | | |
|---------------------|----------------------|--------------------------|
| ① Ground Contact | ⑤ Power Source | ⑨ Correspondence Control |
| ② ISO Contact | ⑥ Holder Information | ⑩ Ground Contact |
| ③ Reference Voltage | ⑦ Holder Information | |
| ④ — | ⑧ Clock Contact | |

Only the RZ67 Pro IID Offers All These Important Features and Advantages

Mamiya pioneered the 6x7cm medium format SLR system camera when it introduced its first model, the RB67 Professional in 1970. The RZ67 Professional followed in 1982 and offered greater automation by combining modern electronics with improved mechanical features. It became the favorite camera of the world's top photographers. Now we are proud to present the RZ67 Professional IID and dedicated accessories, which offer even more improvements, features and advantages.

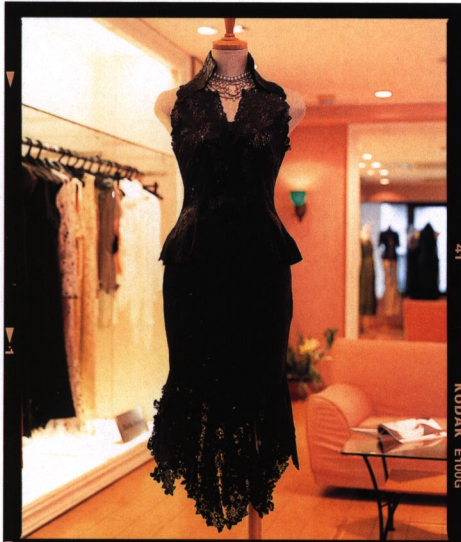

KODAK E100G 41



KODAK E100G 42



KODAK E100G 43

KODAK E100G 44

Intermediate Shutter Speed Settings.

The shutter speed dial of the RZ67 Professional IID with a shutter speed range of 8sec. to 1/400sec, permits setting intermediate shutter speeds between 1/250 and 4sec. This corresponds to 1/2 f-stop (0.5EV) and allows even more precise exposure control without changing aperture settings and without affecting depth-of-field. The pictures on the left show the subtle exposure differences with intermediate shutter speed settings varying by the equivalent of 1/2 f-stop. Paired with the precision AE (auto-exposure) Prism Finder FE701 for the RZ67 Professional IID with its 1/6 f/stop increments, offers photographers with unprecedented exposure accuracy.



Shutter Speed	
Intermediate Shutter Speed	400 — 1/400sec
	250 — 1/250sec
1/180sec	125 — 1/125
1/90	60 — 1/60
1/45	30 — 1/30
1/22	15 — 1/15
1/11	8 — 1/8
1/5.6	4 — 1/4
1/2.8	2 — 1/2
1/1.4	1 — 1
1.4	2 — 2
2.8	4 — 4
	8 — 8
	B — Bulb
	RBL — for RB-series Lenses position
	AEF — for AE Prism Finder use position

6x7cm-The Ideal Format

6x7 is called the ideal format because it enlarges to the standard 8x10" paper size without cropping thus utilizing the entire image area. The 6x7 format of the RZ67 Professional IID (actual image size is 56x69.5mm) is about 5x larger than a 35mm frame and offers far superior image quality for enlargements or full page magazine reproductions. 6x7 transparencies can be viewed on a light table without magnifiers. Having the choice between a 35mm or 6x7 slide of the same subject, an art director or editor will almost always choose the latter.

Electronic Flash Synchronization

Mamiya RZ67 Professional IID lenses are mounted in #1 electronic leaf shutters with shutter speeds from 8 to 1/400sec. and can be flash synchronized at all shutter speeds. Perfectly balanced flash and ambient fill flash exposure can be controlled for natural well exposed results.

Rack & Pinion Bellows Focusing

A precise plane of focus is, of course, at the heart of professional photography. Mamiya knows accurate focusing demands unparalleled mechanical precision, which is why all Mamiya 6x7 format camera have always employed rack & pinion bellows focusing systems. With a 46mm lens rack, the bellows assures pinpoint focusing over the widest possible range. The standard 110mm lens, for example, can focus down to a distance as close as 31.3cm, while the wide-angle 65mm lens focuses to 8.5cm and the tele lens 180mm to 82.9cm.

The crispness of results at minimum focusing distance is a hallmark of the RZ67 Professional IID

Form Follows Function



A professional camera should become an extension of the photographer's hands, so that its operation is almost instinctive, leaving his/her mind free to concentrate on the subject and giving creativity free rein. This was the aim of Mamiya's design engineers when they created the full-featured RZ67 Professional IID.

Ergonomic Design

With the most frequently used action controls placed on the right side of the camera body, the functions of the film transport/shutter cocking lever, focusing knob and shutter release button, feel like a natural fit to your hands and make hand holding of the camera and fast operation very convenient. Attaching the accessory L-Grip, with its built-in electronic shutter release, further enhances this option. The dimpled, non slip rubberized covering makes the camera comfortable and secure to hold.

Large Focusing Knob with Additional Fine Focus Feature.

Strategically placed next to the shutter cocking/film transport lever, the large, smooth functioning focusing knob, with its supplementary fine focus collar, offers both fast action focus and precision focus. This is especially useful with wide angle lenses because of their great depth-of-field and telephoto lenses which require critical distance setting.

Mechanical Safetylocks; Visual and Audible Warning Signals.

Realizing that the professional photographer must frequently work under pressure, the RZ67 Professional IID incorporates many failsafe features to prevent operating errors. Thus, the shutter cannot be released if the film is not wound or the dark slide not with-drawn. Lenses cannot be changed unless the mirror is cocked, nor can the lens holder be removed from the camera unless

the dark slide is in place. Other Safetylocks control the proper setting of the camera's speed dial. Glowing or flashing LEDs, visible in the viewfinder and/or audible electronic sounds inform the photographer of all incorrect camera control settings and are explained in the instruction manual.

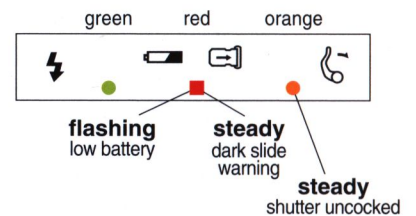

Mamiya Revolving Back With Automatic Finder Masking

The Revolving Back - a Mamiya exclusive among 6x7 SLRs - can be rotated for horizontal or vertical format without changing the optical axis. At the same time it also automatically changes the masking frame in the viewfinder to match the format.

Two Film Counter Windows

RZ67 Professional IID film holders feature two film counter windows for easy reading in either horizontal or vertical position.



Single Action, Triple Function, Film Advance Lever

Film advance, shutter cocking and mirror setting are accomplished with a single stroke of this lever. When the optional RZ Power Winder II is attached to the camera, pressing the camera shutter release will automatically activate these functions.



Z250mm f/4.5W+Extension Tube No.1

Nomenclature & Specifications

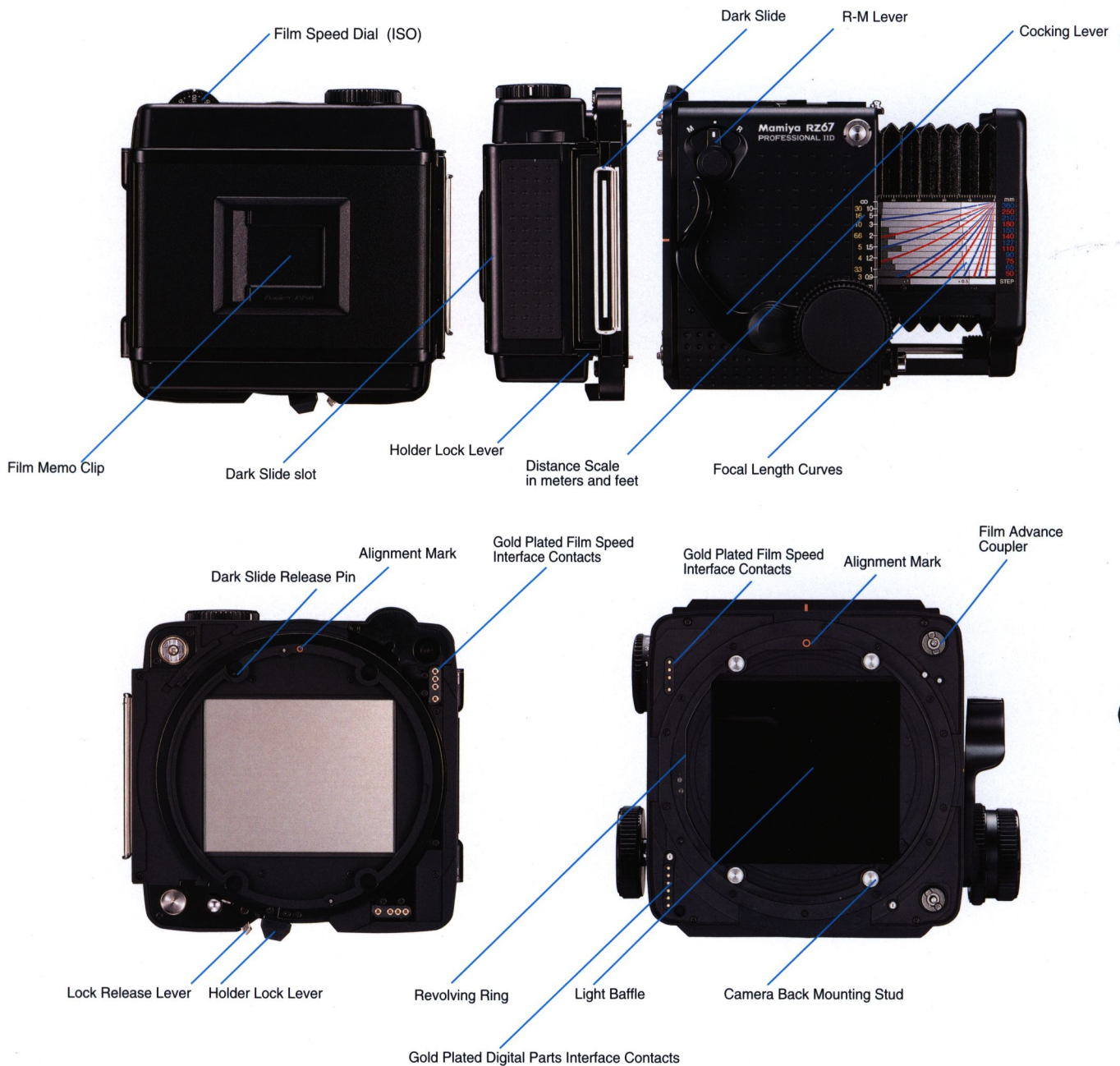

MAMIYA RZ67 Professional IID «Specifications»

Type:	6×7 format lens-shutter SLR
Format:	6×7cm (56×69.5mm with 120/220 roll film)
Film Holders:	Revolving camera back accepts various holders with film speed index dial and film counter.
Lens Mount:	Bayonet mount with electronic connections and built-in safety lock
Lenses:	Interchangeable Mamiya-Sekor Lens-shutter optics; standard lens is 110mm f/2.8W
Shutter:	#1 electronic lens shutter with speeds of 8" to 1/400" plus mechanical B and T settings, RBL (for RB-series lenses) and AEF (for AE Prism Finder use); accepts X-flash or camera hot-shoe synch

Shutter Release:	Electromagnetic with lock. Emergency mechanical operation at 1/400sec. only
Film Advance:	Single-action lever with 114° stroke; cocks shutter and mirror actions; Power-Winder available
Multiple Exposure:	R/M lever at M position
Focusing:	Rack/pinon bellows mechanism with Tension control; bellows extension to 46mm with fixed indicator of film plane-to-subject distance and magnification
Viewfinder:	Waist-level with sealed magnifier (2.9×) and operating indicators; other viewfinder options



- Field-of-View:** 95% (*) with automatic revolving mask for vertical/horizontal image
- Safety Functions:**
- Viewfinder – LEDs indicate operating status, lens cap, battery level
 - Audible Warnings – If shutter dial at RBL with RZ lens attached; if shutter dial at AEF after AE Finder is removed; if shutter dial is not at RBL with RB lens or no lens attached; when battery is too low for operation
 - Release Lock – When shutter/film advance not cocked; when dark slide attached; when RZ lens with shutter dial is at RBL; when RB lens or no lens with shutter dial is not at RBL

- Finder Screen:** Type A matte screen with Fresnel lens standard; interchangeable screen optional
- Release Options:** Electromagnetic cable release contacts on camera body also accepts mechanical cable release, self-timer release, remote control release set
- Power:** One 6V silver-oxide (4SR44) or alkaline (4LR44) battery
- Dimensions / Weight:** 108 × 133.4 × 212.5mm(W × H × L)/2,490g with 110mm f/2.8W lens and 120 Roll Film Holder (HA703)

(*) This information is based on a linear (horizontal/vertical) measurement. Specifications subject to change without notice.

World-Class Mamiya Lenses

Mamiya's world-class lenses, combined with the equally renowned mechanical precision of Mamiya camera bodies and film holders are the foundation of Mamiya's reputation as being top in the medium format camera field. Mamiya designs and manufactures its own optics, using the latest optical glass and coating technologies and computerized processes.

Wide-angle lenses Fisheye Z37mm f/4.5W , Z50mm f/4.5W , ULD M50mm f/4.5L , M65mm f/4L-A

This 37mm fisheye lens provides a 180-degree field-of-view for unique perspective. The super wide-angle Z50mm f/4.5W lens allows detailed resolution of even peripheral elements. The M50mm ULD f/4.5L-A is a high-performance lens that employs ultra-low dispersion and anomalous dispersion glass to achieve an extremely small amount of chromatic aberration. Due to the use of a floating-element system, clear and uniform images can be obtained edge-to-edge in the 6x7 image area. The M65mm also employs a floating-element design and ultra-low dispersion glass to optimize color correction, eliminating ghost images and fully corrects optical distortion.



Fisheye Z37mm f/4.5W

Standard lenses Z90mm f/3.5W , Z110mm f/2.8W

The 90mm is a retrofocus design providing excellent, even contrast all the way to the periphery of the frame as well as high resolution. The 110mm is a Gauss design to offer extra brightness at a maximum aperture of f/2.8, full correction of optical distortion and fine resolution.



Z110mm f/2.8W



Lens	Fisheye Z 37mm f/4.5W	Z50mm f/4.5W	ULD M50mm f/4.5L	M65mm f/4L-A	Shift Z 75mm f/4.5W	Z90mm f/3.5W	Z110mm f/2.8W	Macro M 140mm f/4.5M/L-A
Optical Construction	9 elements 6 groups	11 elements 9 groups	15 elements 11 groups	9 elements 8 groups	11 elements 9 groups	6 elements 6 groups	6 elements 5 groups	6 elements 4 groups
Angle of view	180°	84°	82°	68°	62°	53°	44°	35°
Minimum aperture	32	32	32	32	32	32	32	32
Diaphragm	Automatic	Automatic	Automatic	Automatic	Automatic	Automatic	Automatic	Automatic
Minimum Focusing distance	0.26m	0.28m	0.29m	0.35m	0.42m	0.43m	0.53m	0.6m
Maximum magnification ratio	1.23	0.9	0.88	0.7	0.6	0.51	0.42	0.3
Area Covered	45x56mm	62x77mm	63x78mm	80x100mm	93x115mm	110x136mm	135x167mm	173x214mm
Equivalent focal length for 35mm	18mm	24mm	24mm	32mm	36mm	44mm	53mm	68mm
Filter size	40.5mm	77mm	77mm	77mm	105mm	77mm	77mm	77mm
Lens hood	None required	Slip-on	Slip-on	Slip-on	None required	Screw-in	Screw-in	Screw-in
Dimensions (LxW)	100.3x112mm	82.2x97.2mm	92.7x97.2mm	113x97.2mm	152x108mm	82.1x97.2mm	62x97.2mm	97x97.2mm
Weight	1,280g	760g	954g	1,060g	1,660g	690g	610g	930g

The Shift Z 75mm f/4.5W can be shifted 20mm vertically and horizontally, and 17mm diagonally. In case it has been shifted more than 17mm, depending on how the direction in which the lens is shifted is combined with extension, part of the shorter side of the picture area may be clouded outside the visible field of view.

Telephoto lenses Z150mm f/3.5W, Z180mm f/4.5W-N, Z250mm f/4.5W

The 150mm and 180mm lenses display high image quality and natural coloring throughout the whole picture even after opening up the aperture due to an increase in the amount of peripheral light. The 180mm lens is a Tessar type. The 250mm lens can achieve high image quality and natural coloring, as in the case of the 150mm and 180mm lenses, through the suppression of chromatic aberration and an increase in the amount of peripheral light.



Z250mm f/4.5 W

Macro lens Macro M140mmf/4.5 M/L-A

The Macro M140mm lens is a Gauss-type lens. Through the adoption of a floating mechanism and maximum correction of various aberrations, clear high resolving power has been enabled from the center of the picture to its periphery. Naturally, shooting from a close distance up to infinity is possible and users can enjoy taking realistic portrayals with image ratios up to 1:1 through the use of an Extension Tubes.



Macro M140mm f/4.5 ML-A

Z150mm f/3.5W	Z180mm f/4.5W-N	Soft M180mm f/4D/L	Z250mm f/4.5W	Zoom Z100-200mm f/5.2 W	APO 210mm f/4.5	APO 250mm f/4.5	APO 350mm f/5.6	APO 500mm f/6
Z150mm f/3.5W	Z180mm f/4.5W-N	Soft M180mm f/4D/L	Z250mm f/4.5W	Zoom Z100-200mm f/5.2W	APO 210mm f/4.5	APO 250mm f/4.5	APO 350mm f/5.6	APO 500mm f/6
elements 4 groups	4 elements 3 groups	6 elements 4 groups	5 elements 4 groups	14 elements 12 groups	7 elements 5 groups	7 elements 5 groups	7 elements 6 groups	7 elements 7 groups
33'	28'	28'	20'	48"-25"	24'	21"	15'	10'
32	45	32	45	45	45	45	45	45
Automatic	Automatic	Automatic	Automatic	Automatic	Automatic	Automatic	Automatic	Automatic
1.1m	1.10m	1.05m	1.85m	(W)0.55m-(T)1.22m	1.43m	1.86m	3.42m	6.49m
0.11	0.26	0.26	0.19	(W)0.45-(T)0.24	0.22	0.19	0.13	0.09
183x277mm	217x270mm	211x262mm	297x369mm	(W)126x156mm-(T)237x294mm	256x318mm	298x370mm	420x521mm	597x740mm
73mm	87mm	87mm	121mm	48-97mm	102mm	119mm	167mm	238mm
77mm	77mm	77mm	77mm	77mm	77mm	77mm	77mm	105mm
Screw-in	Screw-in	Screw-in	Screw-in	Slip-on	Screw-in	Screw-in	Screw-in	Screw-in
83x97.2mm	119.3x97.2mm	118x97.2mm	126x97.2mm	173x108.5mm	114x97.2mm	144.8x97.2mm	191.2x97.2mm	278.5x108mm
825g	900g	1,039g	1,080g	1,620g	980g	1,340g	1,455g	2,315g

When photographing with the Zoom Z100-200mm lens at 3m-∞, use the lens helicoid for focusing. When taking close-up within 3m, set the helicoid at ∞ and extend the body bellows for focusing. Data on the minimum focusing distance, minimum magnification and area covered only this lens denote those when the helicoid is at the infinity position and the bellows are most extended.

Zoom lens Zoom Z100-200mm f/5.2W

The 100-200mm zoom lens is the first zoom lens for a 6×7-format camera. It is always possible to achieve optimum framing from a distance of infinity to close range, even when there are constraints on the distance between subjects. Naturally, portrait shooting is possible and this lens is suitable for various kinds of photography. Moreover, as optical performance approaches the level of a single focus lens, excellent portrayal capability can be achieved.



Zoom Z100-200mm f/5.2W(100mm)



Zoom Z100-200mm f/5.2W(200mm)

Vari-Soft focus lens M180mm f/4 D/L

The M180mm Variable Soft Focus (VSF) lens presents the most desirable focal length for the portrait photographer. It is supplied with three different diffusion discs which are inserted in the lens barrel. The overall level of softness (or sharpness) is controlled by the diaphragm opening, choice of disc, and whether or not a disc is used at all. It can produce images of a certain ethereal beauty which cannot be obtained by any other means, hides blemishes and saves retouching costs. When stopped down to f/8 or smaller apertures, it produces sharp images like a normal lens.



Soft M180mm f/4 D/L+No.2 Grid

Shift lens Z75mmf/4.5W

The Shift 75mm lens provides versatile perspective control to the photographer to correct converging parallel elements within the image, or, conversely, to exaggerate perspective shifts to achieve special effects. It offers a maximum 20mm shift in either vertical or horizontal orientation, 17mm at angular orientation, and can be rotated through 360 degrees in 10-degree click stops.



Shift Z75mm f/4.5W(Shift)

APO Lenses APO 210mm f/4.5 , APO 250mm f/4.5 , APO 350mm f/5.6 , APO 500mm f/6

The most advanced optical technology was applied to this APO-Sekor series of professional telephoto lenses. The design incorporates elements made from ultra-low dispersion glass, a material which enables the lens designer to practically eliminate color aberrations, spherical aberrations and other types of optical distortion. These lenses provide high levels of detail, free from flare and ghost images, and produce images of total color fidelity. These lenses are just one more example of Mamiya's commitment to provide the professional with the very best photographic system, the RZ67 Professional IID. Mamiya apochromatic lenses employ ultra low anomalous dispersion glass for internal lens elements to eliminate the chromatic aberrations that affect images transmitted by standard telephoto optics through conventional lens design. This correction extends to the infrared spectrum.



APO 350mm/f5.6



APO 500mm/f6

SB Lenses for Shift / Tilt Adapter

M75mm f/4.5L SB; M180mm f/4.5L SB

SB (Short Barrel) lenses are designed for use with the Shift/Tilt Adapter, but are not limited to such use. The SB lenses allow continuous focusing from infinity to close-up when attached to the Shift/Tilt Adapter. The SB lenses may also be used on the Mamiya RZ camera without the Shift /Tilt Adapter and with the addition of the 27.2mm Auto Spacer, will focus continuously from close-up to infinity. Both the 75mm and the 180mm SB lenses are state-of-the-art designs capable of rendering exceptional resolution and contrast. Both use Mamiya's own Formulation of high density/low dispersion glass as well as proprietary lens multi coating. (The 75mm SB lens does not have a built-in 75mm lens shift function.)



M180mm/f4.5 L Shift / Tilt adjustment



Normal



M75mm f/4.5L SB



M180mm f/4.5L SB



Spacer for SB lenses

Shift / Tilt Adapter NI701

Shift/Tilt movements to capture broader range of expression that give professional photography a more delicate touch.

The shift (rise and fall) range of 10mm controls perspective; the 12 degrees of tilt adjustment (setting indicated on scale) enhances depth of field control. The shift and tilt adjustments can be used both separately and in combination. Full single lens reflex capability is maintained, making focus, composition control and all other photographic functions as easy as ever. TTL metering is also possible with the AE Finder in place. Use of the following lenses is recommended: 110mm, Macro 140mm, 150mm, 180mm, 210mm APO.

When using the 6x7 Roll Film Holder, some combinations of shift and tilt adjustments, aperture and lens focal length can cause vignetting or a fall-off of marginal illumination. To prevent this, use the narrowest possible aperture setting.



Shift/Tilt Adapter NI701

Shift/Tilt Adapter NI701+M75mm/f4.5L SB

Specifications	M75mm f/4.5L SB	M180mm f/4.5L SB
Lens construction	11 elements in 9 groups	4 elements in 3 groups
Field angle	62°	28°
Aperture mechanism	Automatic	Automatic
Minimum aperture	45	45
Equivalent focal length for 35mm	36mm	87mm
Minimum shooting distance	576mm (stand alone) 416mm (with spacer attached)	2,101mm (stand alone) 1,099mm (with spacer attached)
Magnification ratio	0.24 times (stand alone) 0.6 times (with spacer attached)	0.1 times (stand alone) 0.26 times (with spacer attached)
Shooting range	231x286mm (stand alone) 93x115mm (with spacer attached)	540x671mm (stand alone) 217x270mm (with spacer attached)
Filter diameter	105 mm	77 mm
Hood (attached to lens)	-	Screw-in
Dimensions (length x diameter)	124.5 x 108mm	91.8 x 97.2mm
Weight	1,295g	808g

System Accessories

Film Holders

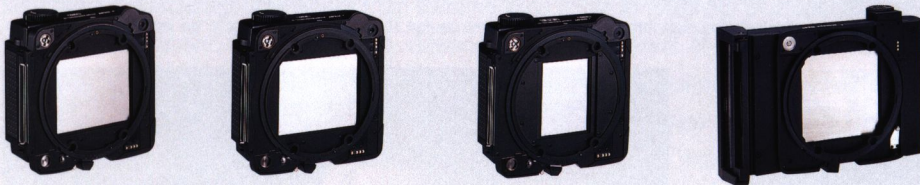

	120 Roll Film Holder HA703	220 Roll Film Holder HB702	6x4.5 120 Roll Film Holder HA704	Polaroid Land Pack Film Holder HP 702
Film Type	120 Roll Film	220 Roll Film	120 Roll Film	Polaroid Land Pack Film (100&660 Series)
Actual Film Image Size	56x69.5mm	56x69.5mm	56x41.5mm	69.5x69.5mm
Number of Exposures	10 exposures	20 exposures	15 exposures	8 exposures
Film Advance System	The film is advanced with a single 114° stroke of the cocking lever, and can also be advanced with the Film Advance Knob of the Film holder.			Peel Apart System
Additional Features	Built-in double exposure prevention, multiple exposure provision, automatic film wind-stop release, built-in Film Speed Dial. Exposure Counter with automatic return, Film-Unadvanced indicator, automatic Dark Slide lock and release Memo Clip, built-in Dark Slide Slot.			Built-in Film Speed Dial
Weight	530g	530g	530g	330g



Focusing Hood FW702

This convenient waist-level focusing hood pops open with a single touch to provide bright screen viewing of the entire frame; raising the center magnifier makes fine focusing quick and easy, while also creating a completely light-tight hood. With the 110mm standard lens, the focusing hood provides a 1:1.28 image, increased to 1:2.9 with the magnifier. The standard magnifier lens features diopter -1.5 correction, five additional diopter correction lenses are available in steps from +1 to -3. Weight: 150g

Focusing Screen

Type A Matte

A matte screen with Fresnel lens for general purpose photography.

Type A3 Matte

A matte screen with Fresnel lens for general purpose use, incorporating special corner masks to ensure full viewfinder masking in the vertical format.

Type A4 Checker

A matte screen with Fresnel lens and sectional grid markings, suitable for close-up, copy and architectural applications.

Type C Microprism

A matte screen with Fresnel lens and microprism center focusing aid, suitable for general photography and other applications. Focusing is also possible in surrounding matte area.

Type D Cross-hair

A matte screen with transparent center set with cross hair marker, suitable for high-magnification, close-up or telephoto special applications with parallax focusing.

Type E Rangefinder Spot/Microprism

A matte screen with Fresnel lens and horizontal split-image center focusing aid surrounded by microprism collar. Suitable for general applications where horizontal/vertical elements can be accurately focused via the split-image, or general area focusing via the microprism. Focusing is also possible in surrounding matte area.



AE Prism Finder FE701

This aperture-priority AE finder offers both spot and averaged metering choices, as well as its own special auto-selection function that switches between spot and averaged automatically to suit the shooting conditions.

Type : correct-image prism viewfinder
 Magnification : 0.81x with 110mm lens (1.8x loupe)
 Correction : -0.8 diopter (standard) with correction lens thread
 Metering Type : TTL with averaged, spot or auto averaged/spot selection
 Metering Range : EV1-EV18.5 (f/2.8 at 4" to f/32 at 1/400") with 110mm f/2.8W lens
 Shutter Speeds : automated 8-1/400sec. (in 1/6 EV steps)
 manual 8-1/400sec. (in 1/2 EV steps)
 Film Sensitivity : ISO 25-6400 (in 1/3 steps)
 Finder Indicators : backlight LED indicators for shutter speeds (1-1/400sec.; LT mechanical shutter operation indicated in seconds by dual LEDs; exposure range limits indicated by blinking or LT LEDs; metering choice indicated by A/S LEDs; manual exposure indicators light red/orange/green
 Exposure Compensation : ±3EV (in 1/3 steps)
 AE Lock : function-selectable
 Power : operates on camera power (with camera shutter dial set to AEF position)
 Weight : 940g



Digital Back Adapter HX701 (to be available)

This adapter allows the attachment of digital backs compatible with the Mamiya cameras exclusive digital communication specification (MSCE). Equipped with a revolving mechanism, which permits vertical or horizontal composition.

Size: 114mm (w) x 16.8 (d) x 114 (h) mm (with the revolving knob)

Weight: 106g



Winder RZ Model II

An extremely important accessory for almost all professional applications, the Winder RZ frees the photographer from the need to manually activate the film advances/shutter mechanism. This lets the photographer concentrate fully on subject, while the motorized winder takes care of the film, shutter and mirror settings. Single-frame or sequential film advance (1.5sec/per frame); the Winder RZ Model II is powered by six AA type alkaline cells (500-600 consecutive shots are possible), or six Ni-Cd batteries (300-360 consecutive shots are possible).

Dimensions: 100(w) x 43(h) x 95(d)mm, Weight: 550g (without batteries)

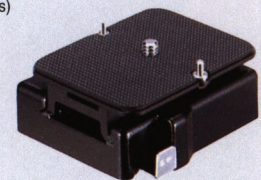

Quick-Shoe AQ701

The shoe that makes tripod-mounted camera changes quick and easy. Slip on a camera and it instantly locks in place on the shoe automatically. A double-action release mechanism allows quick operation while protecting against automatic release.

Weight: 225g

L-Grip Holder RZ

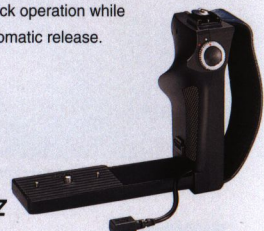

A contoured left-hand grip that provides excellent balance for both hand-held shooting and for carrying. The grip is equipped with a locking shutter release (electronically linked to the camera's own release) and a cold-shoe for accessories. Weight: 390g



Mirror Lock-up Cable Release

Perfect tool to prevent even the slightest shake during slow-shutter-speed exposures; one cable connects to the camera body's shutter release, the other to the Mirror Lock-up switch. When the release is pressed, the Mirror Lock-up operation activates first, followed by operation of the shutter. Very useful for both close-up and telephoto applications. Weight: 90g

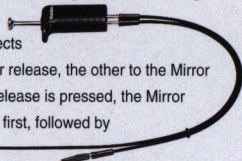

Magnifier (for Prism Finder)

Attached to the prism finder, it assures enhanced precision focusing by magnifying the central portion of the screen. After focusing, it can be raised to confirm overall composition. Built-in -6 to +4 diopter correction. Weight: 70g



Tele-Converter 1.4×RZ

This teleconverter is optically designed to provide the best possible results in use with the superior Z series lenses; it provides an effective focal length extension of 1.4x, and can be recommended for the following Z series lenses; 90mm, 110mm, 140mm, 150mm, 180mm. Dimensions (L×W): 37×97.2mm Weight: 430g



Gelatine Filter Holder Model 2

A Special holder for 3-inch (7.5cm) gelatine filters; attaches to 50, 65, 90, 110, 140, 150, 180, 210, 250, and 350mm lenses. This holder is indispensable for accurate correction of color (under differing types of light, for example). The holder allows insertion of multiple filters. Weight: 45g



Bellows Lens Hood G-2

Attaches to the front accessory thread of Z series (90mm-350mm) lenses; provides optimum shading of the lens to prevent all stray light. Rack & pinion adjustment for selection of optimal setting by actual preview; width is easily adjusted; incorporates gelatine filter holder. Maximum and minimum extension of bellows: 110mm and 30mm Weight: 290g

Auto Extension Tube RZ

This series of extension tubes, for close-up and macrophotography, provides fully automatic shutter operation. The two automatic tubes can be used individually or in combination. No.1=45mm extension; No.2=82mm; No.1+2=127mm. Since the camera body bellows features an extension of 46mm, using the tubes provides a total maximum extension of 173mm. Weight: No.1...330g, No.2...410g



Close-up Table

Lens	Extension Tubes	Magnification	Subject Distance(cm)	Area covered (cm)
M65mmf/4L-A	No.1	0.68 ~ 1.38	8.7 ~ 3.9	(8.2×10.2) ~ (4.1× 5.0)
	No.2	0.50 ~ 1.01	20.1 ~ 11.0	(11.2×13.9) ~ (5.5× 6.9)
Z90mm f/3.5W	No.1	0.91 ~ 1.42	12.0 ~ 8.4	(6.1× 7.6) ~ (3.9× 4.9)
	No.1+No.2	1.41 ~ 1.92	8.5 ~ 6.8	(4.0× 4.9) ~ (2.9× 3.6)
Z110mmf/2.8W	No.1	0.41 ~ 0.82	31.9 ~ 18.1	(13.8×17.1) ~ (6.8× 8.5)
	No.2	0.74 ~ 1.15	19.6 ~ 14.2	(7.6× 9.4) ~ (4.8× 6.0)
Macro M140mm f/4.5M/L-A	No.1	1.15 ~ 1.56	14.3 ~ 11.7	(4.9× 6.1) ~ (3.6× 4.5)
	No.2	0.32 ~ 0.64	52.2 ~ 29.7	(17.6×21.9) ~ (8.7×10.8)
Z150mm f/3.5W	No.1	0.58 ~ 0.90	32.1 ~ 23.3	(9.7×12.0) ~ (6.2× 7.7)
	No.1+No.2	0.90 ~ 1.22	23.4 ~ 19.2	(6.3× 7.8) ~ (4.6× 5.7)
Z180mm f/4.5W-N	No.1	0.30 ~ 0.61	59.5 ~ 34.1	(18.7×23.2) ~ (9.3×11.5)
	No.2	0.55 ~ 0.85	36.8 ~ 26.9	(10.3×12.7) ~ (6.6× 8.2)
Z250mm f/4.5W	No.1+No.2	0.85 ~ 1.15	27.1 ~ 22.3	(6.6× 8.2) ~ (4.9× 6.0)
	No.1	0.25 ~ 0.51	84.5 ~ 48.7	(22.2×27.6) ~ (11.0×13.6)
Z180mm f/4.5W-N	No.2	0.46 ~ 0.72	52.5 ~ 38.6	(12.2×15.1) ~ (7.8× 9.7)
	No.1+No.2	0.71 ~ 0.97	38.8 ~ 32.1	(7.9× 9.8) ~ (5.8× 7.2)
Z250mm f/4.5W	No.1	0.18 ~ 0.37	160.0 ~ 93.1	(30.4×37.7) ~ (15.0×18.6)
	No.2	0.34 ~ 0.52	100.2 ~ 74.1	(16.7×20.7) ~ (10.7×13.3)
Z250mm f/4.5W	No.1+No.2	0.52 ~ 0.71	74.5 ~ 62.0	(10.8×13.4) ~ (7.9× 9.8)

Bellows Lens Hood G-3

Utilizing side struts, instead of base rails, this Bellows Lens Hood G-3 provides highly efficient protection against extraneous light and it has inserting slots for 3 inch (7.5cm) square filter and 12cm square size vignetter. Vignetter can adjust up and down within 14mm. Gelatine filter mount is provided. Maximum and minimum extent of bellows: 175mm and 50mm. Weight: 335g



Front Hood for G-3

Using the Front Hood for G-3 along with Bellows Lens Hood G-3 will bring higher vignetting efficiency. With the Front Lens Hood used along with Bellows Lens Hood G-3, it can be possible to use 50mm f/4.5W lens or longer focal length lenses, expect for 100-200mm zoom lens and 500mm APO lens. Front Hood for G-3 has an inserting slot for 12cm square size vignetter. Maximum and minimum extent of bellows: 105mm and 25mm Weight: 145g

Electromagnetic Cable Release

Connects to the electronic shutter release socket of the camera. Type A: Coil Cord, approx. 1m long, weight: 39g

Mamiya Aluminum Trunk

A light brown finish with alumite treated surfaces and high-strength prism cut resin corner guards for a trunk that's both good looking and tough. The interior can be freely partitioned to store cameras and lenses, and all interior surfaces are cushioned with a thin urethane layer. The top of the trunk has packets that can be used to store accessories and other small items. Available in three different sizes.

Model No.	Outside: W×D×H mm	Weight
	Inside: W×D×H mm	
KM705	460×344×160	3.7
	440×325×100	
KM706	502×371×183	4.9
	470×350×115	
KM707	615×371×183	5.7
	580×350×115	



Remote Control RS401

Consists of Transmitter and camera-mounted Receiver. Choice of three infrared channels for interference free operation. 30m operating range. Transmitter uses two AA Alkaline, Receiver one 9 Volt, batteries. Weight: Transmitter: 130g (without batteries) Receiver: 140g (without batteries)

RZ67 Professional IID System

Film Holder

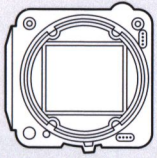

120 Roll Film Holder HA703

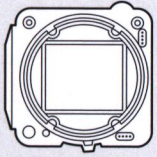

220 Roll Film Holder HB702

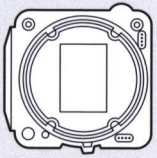

120 Roll Film Holder 6x4.5 HA704

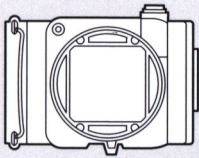

Polaroid Land Pack Film Holder HP702

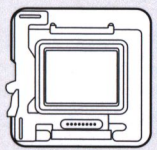

Digital Back Adapter HX701
(to be available)

Digital Camera Back

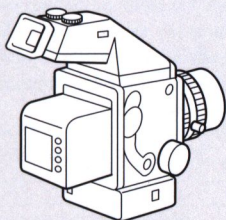

Correction Lenses for the Prism Finders

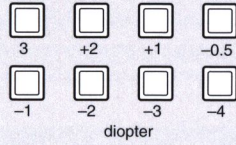

diopter



Magnifier

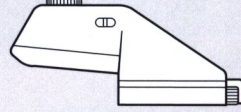

AE Prism Finder FE701

Viewfinders

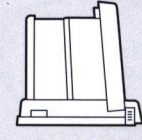

Focusing Hood FW702

Correction Lenses for the Focusing Hood RZ

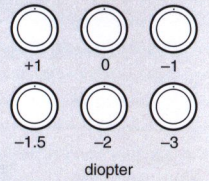

diopter

*The finder system for the RB can also be used.

Focusing Screens

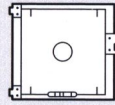

Type A Matte

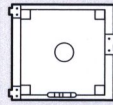

Type A3 Matte

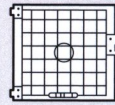

Type A4 Checker

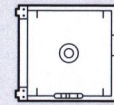

Type B Range Finder Spot

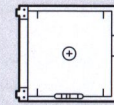

Type D Cross Hair

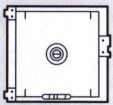

Type E Range Finder Spot/Microprism

RZ67 PROFESSIONAL IID

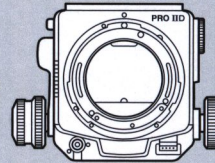

Camera Body

Close-up Attachments

Auto Extension Tubes RZ

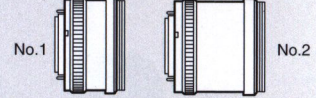

Remote Control

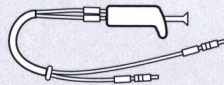

Mirror Lock-up Cable Release

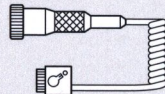

Electromagnetic Cable Release
Type A: Coil cord approx. 1m

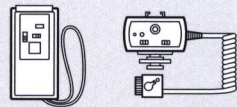

Remote Control RS401

Power Winder

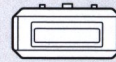

Winder RZ Model II

Grip

L-Grip Holder RZ

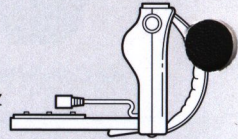

Tripod Monopod Head

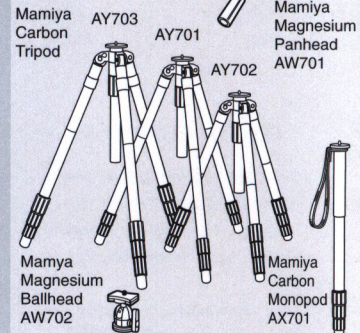

Camera Case/Strap

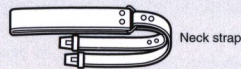

Neck strap

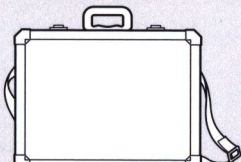

Mamiya Aluminum Trunk KM705, KM706, KM707



Soft Leather Lens Case RZ No.4 for 37mm lens



Soft Lens Case Type C for 50, 65, 75 f/3.5, 90, 110, 140 and 150mm lenses

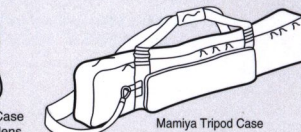

Mamiya Tripod Case

Shift / Tilt

Shift/Tilt Adapter NI701

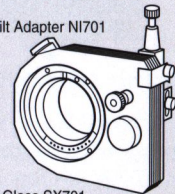

(with Relay Cord)

Grand Glass SX701

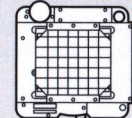

(for Shift / Tilt Adapter)

Lenses

Wide

- Fisheye Z 37mm f/4.5W
- Z50mm f/4.5W
- ULD M50mm f/4.5L
- M65mm f/4L-A

Standard

- Z90mm f/3.5W
- Z110mm f/2.8W

Mid-range

- Macro M140mm f/4.5M/L-A
- Z150mm f/3.5W
- Z180mm f/4.5W-N

Telephoto

- Z250mm f/4.5W

Zoom lens

- ZOOM Z100-200mm f/5.2W

Soft Lens

- SOFT M180mm f/4 D/L

Shift Lens

- Shift Z75mm f/4.5W

APO Lenses

- APO 210mm f/4.5
- APO 250mm f/4.5
- APO 350mm f/5.6
- APO 500mm f/6

Tele-converter

- Tele-converter 1.4xRZ

SB Lenses for Shift / Tilt Adapter

- M75mm f/4.5L SB
- M180mm f/4.5L SB
- Spacer for SB Lenses

Filter

- Filter (40.5mm ϕ) for 37mm Fisheye Lens UV (SL-39), SL-1B, LB-A, LB-B
- Filter (77mm ϕ) PL
- Filter (105mm ϕ) UV, SL
- Gelatine Filter Holder Model 2 (80mm ϕ)

Lens Hoods

- Bellows Lens Hood G-2
- Bellows Lens Hood G-3
- Front Hood for G-3
- Gelatine Filter Mount for G-3
- Zoom lens Mounting Ring for G-3
- Lens Hood ϕ 80mm No.1 Slip-on type for 50mm and 65mm lenses
- Lens Hood M77 No.1 Screw-in type for 90, 110 and 140mm lenses
- Lens Hood M77 No.2 Screw-in type for 150, 180, 210, 250 and 350mm lenses
- Lens Hood ϕ 108 No.1 Slip-on type for 500mm lens
- Lens Hood ϕ 80 No.3 Slip-on type for Zoom 100-200mm lens

Other Accessories

- Lens Holder for 350mm lens
- Lens Holder for 500mm lens
- Lens Holder for 100-200mm Zoom lens
- External Battery Case

*Interchangeable lenses for the RB can also be used. (When using interchangeable lenses for the RB, contact your nearest Mamiya Service Center for lens inspection.)

*Specifications and appearance are subject to change without notice.

~~219-64~~

Mamiya