

Original

**EXA
EXAKTA**

Dresden

Accessories

Close-up Photography
Slide Copying
Reproductions
Close-up Flash Technique
Photography of Body Cavities
Spectro Photography
Photomicrography
Astro-Photography



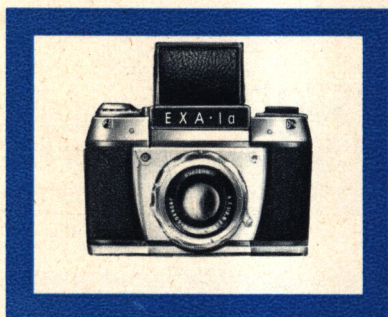

Versatility and adaptability

are the principal characteristics of the Ihagee single-lens miniature reflex cameras, the EXAKTA VX 1000, EXA 500, and EXA 1a. These qualities are reflected both in the design of these cameras and also in their wide variety of accessories, on which the value of a modern "system camera" so much depends. A carefully-planned range of supplementary equipment enables Ihagee cameras to cater for all the needs of their users individual fields of work and personal requirements; even the simplest model, the EXA 1a, possesses truly astonishing versatility of application. Considerably wider scope is provided by the EXA 500, whilst the top-quality EXAKTA VX 1000 model, in partnership with its innumerable accessories, opens up the most recondite areas of modern miniature photographic technique.

The decisive advantage of these Ihagee cameras lies in the fact that, as single-lens reflex instruments, they allow all accessory equipment to be treated as a truly integral extension of the camera. The parallax-free image on the focusing screen remains a dependable guide under all circumstances; it is only in this way that it is possible to provide such a variety of essentially simple accessories at such a moderate cost. In addition, these cameras remain exceptionally simple and efficient to operate, whilst providing all the reliability and confidence which results from the fact that both they and their accessory equipment are almost exclusively produced by the same manufacturers, so allowing them to be matched together down to the smallest detail. This is yet another of the advantages offered only by first-quality "system" cameras.

The world-renowned EXAKTA system also embraces the two EXA models, which in many instances can play the role of second and third cameras to their senior partner. The majority of the accessories—even if in this booklet they are shown only in combination with one particular camera—can be employed with all three models. Any restrictions on the employment of the EXA models are described in the text.

We trust that this manual will assist you in the selection of your photographic equipment and will also provide you with useful hints for extending the bounds of your photographic activities. We are of course always ready to supplement this information with our own personal advice and suggestions.

**I H A G E E K A M E R A W E R K A G in Verwaltung
8 0 1 6 D R E S D E N**



Close-up pictures

All small objects which normally have to be viewed at very close distances—possibly even with the aid of a magnifying glass—necessarily have to be photographed close to the camera lens. This is why close-up photography is a professional necessity in every branch of science, technology and art as well as in the day-to-day work of the commercial photographer; for the amateur it can be a most fascinating and instructive pastime. The design of our 35 mm reflex cameras (EXAKTA VX 1000, EXA Ia, and EXA 500) makes them particularly suitable for taking close-up pictures. (With the EXA Ia and its preceding models there are admittedly slight restrictions in their close-up applications, which by no means exclude the employment of these cameras for taking pictures at short distances.) The fact that the ground-glass screen ensures that there is never any difference caused by parallax displacement between the coverage of the finder image and of the final photograph makes all these models ideal for taking pictures at even the closest distances. If the EXAKTA or EXA is brought closer to the subject, the distance between the lens and the focused image must be increased—as with every other camera—but this does not affect the operation of the single-lens reflex. The increase in lens extensions can, therefore, be achieved by purely mechanical means, whilst the magnified viewfinder image remains just as reliable a guide to the image framing and focus, depth of field, colour composition and all other aesthetic factors as in any other kind of photograph. The finder image must necessarily be identical and free from parallax relative to the image on the film, since both are formed by the same lens. The EXAKTA and EXA cameras require no supplementary focusing aids for taking pictures at close distances. Since Ihagee cameras all possess one universal type of bayonet lens mount, the various accessories for close-up work can be used with all three models. Special types of lenses can also be used for close-up pictures: wide-angle lenses allow pictures to be taken at a shorter distance, and long-focus lenses can be used at greater distances, whilst still preserving the same image scale. Both these facilities can often be of great value. Extra-wide-angle lenses (with a focal length of less than 30 mm) are not suitable for close-up pictures with mechanical extension devices, whilst extreme long-focus lenses must frequently be excluded because of their weight.

If when using the EXA Ia and its preceding models in conjunction with Bayonet Adapter Rings and Extension Tubes the distance between the lens and film plane is extended to more than 70 mm, a small area will be left unexposed along each of the longer edges of the negative ("vignetting"). These narrow unexposed strips will be insignificant when using the standard lens with an extension increase of about 20 to 50 mm, since a fully adequate useful image area will remain unaffected; however, longer extensions (e. g. those obtainable with a Bellows Attachment) are not advisable.

Bayonet Adapter Rings and Extension Tubes

The simplest method of increasing the lens extension for close-ups is by using Bayonet Adapter Rings and Extension Tubes, which are available for interpolation between the interchangeable lens of an EXAKTA or EXA and the camera body. The combination can be adjusted at will so as to achieve quickly almost any desired length of extension to suit the task in hand. By adjusting the helical lens-focusing movement to the shortest distance, a range of reproduction scales can be obtained (see table on page 13). This helical focus movement can also be used for fine focusing of the lens.

The **Two-in-One Ring** provides the shortest-possible extension of 5 mm. This is inserted in the camera bayonet and the lens is fitted into the front mount.

The **Set of Adapter Rings and Extension Tubes** consists of a pair of Bayonet Adapter Rings providing an extension of approximately 10 mm and three Extension Tubes of different lengths, giving 5, 15, and 30 mm lens extension. The two Bayonet Rings can be screwed together and used as a single unit, and can also be used separately to provide intermediate adapters for the three tubes, which are provided with screw threads only. The rear Bayonet Ring is provided with a locking ring, which enables the lens to be rotated to its normal position and so locked when using it with the front Bayonet Ring and any of the Tubes (this is particularly important when using the Ihagee Auto-couple Extension Release, described on page 6). The pair of Bayonet Adapter Rings and the three Tubes are supplied only as a complete set

Order numbers: Two-in-One Ring 187
 Set of Bayonet Adapter Rings and Extensions Tubes 180
 (consisting of: pair of Bayonet Rings 181/183, 5 mm Tube 184,
 15 mm Tube 185 and 30 mm Tube 186)

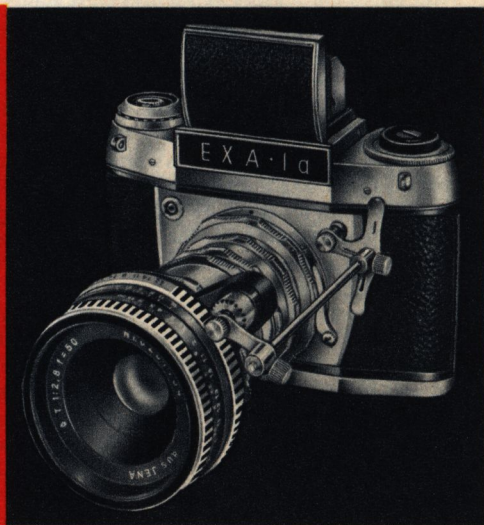



Miniature Bellows Attachment

This easily-carried unit is particularly recommended when taking close-up pictures frequently. It allows the image scale to be adjusted quickly and continuously. The bellows extension has a continuous adjustment range from 35 to 125 mm. The image scale and other focusing data can be altered in seconds at any time. The unit is particularly suitable for taking close-up pictures with a hand-held camera but can also be fitted to any tripod or to the Ihagee Copying Stand ($\frac{1}{4}$ " tripod bushes are provided on both the camera and lens standards).

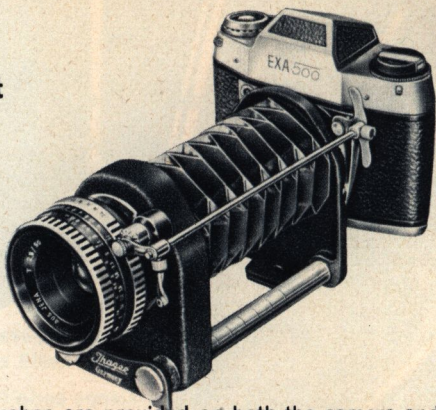

The camera standard of the Miniature Bellows Attachment is designed for attaching the camera in both a vertical and horizontal position. For adjusting the extension to any desired distance between 35 and 125 mm, the lens standard alone is slid along the guide rails and locked in the appropriate position. The left-hand guide rail is calibrated in centimetres.

With a standard lens of 50 mm focal length all image scales between 0.7 (with an extension increase of 35 mm) to 2.5 (with an extension increase of 125 mm) can be obtained, permitting the full-frame reproduction of objects from 34 mm \times 51 mm to 10 mm \times 14 mm in size. If you wish to record full-frame images of larger objects and also require a focusing range extending to infinity, the T f 2.8/50 mm special lens with sunk mount, from Jena, may be employed with the Miniature Bellows Attachment. With this lens an extension range from 0 to 90 mm can be obtained.

Order numbers: Miniature Bellows Attachment 176
Special lens T f 2.8/50 mm with sunk mount, from Jena 128

Ihagee Autocouple Extension Release

In order to operate the fully-automatic pressure or spring diaphragm of the camera lens when employing Bayonet Adapter Rings and Tubes or the Miniature Bellows Attachment, the Ihagee Autocouple Extension Release should be fitted between the lens and the camera body. This unit may be employed with two coupling rods of different length for all lens extension distances up to 125 mm. Its function is to connect the shutter release button on the camera with the diaphragm-release knob or lever on the lens. The camera can be held normally when using the Autocouple Extension Release, so ensuring successful close-up pictures with a hand-held camera even with moving subjects (i. e. small animals), here the fully-automatic diaphragm action is of particular importance.

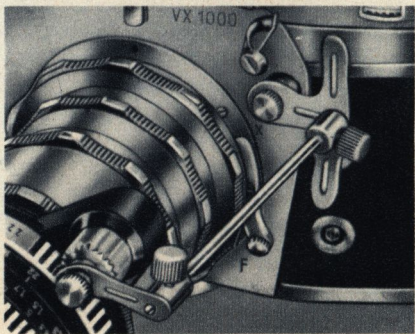

Order number:
Ihagee Autocouple Extension Release 178

The Ihagee "Vielzweck"

This most versatile apparatus is recommended for use whenever it is desired to employ the EXAKTA or EXA with the greatest possible ease and efficiency in every conceivable branch of close-up photography—very possibly as an essential tool in some professional activity. The "Vielzweck" is designed on the "build-up" principle, with separate units which can be employed either alone or in combination with other components. The range of equipment can, therefore, be built up gradually as your requirements grow. The following descriptions of the various ways in which the individual units can be used is by no means exhaustive: just like the Ihagee cameras themselves, the "Vielzweck" is remarkable for the way it can be adapted to perform almost every specialized duty imaginable.

When ordering any of the Ihagee "Vielzweck" note that the following units are supplied as complete sub-assemblies of the Ihagee "Vielzweck" No. 155.17, Copying Stand (e) No. 155.16; Bellows Attachment (a + c) No. 155.10, and Transparency Copying Equipment (d) No. 155.04. All other accessories must be ordered separately.

The Swing Angle Attachment permits exceptionally accurate and convenient close-up focusing when using the Bayonet Adapter Rings and Extension Tubes in conjunction with a heavy tripod. The Swing Angle Top which holds the camera can be slid along the guide rail of the focusing slide, or alternatively the focusing slide may be racked forwards and backwards by turning the rack-and-pinion wheel which moves the guide rail, the Swing Angle Top and the camera as a single unit. In either case the camera can be locked in any desired position. The Swing Angle Attachment can be mounted horizontally on the tripod, or swung into a vertical attitude by using a pan-and-tilt head; it will scarcely ever be necessary to alter the position of the tripod, since the focusing range of the Swing Angle Attachment is sufficient to provide considerable variation of the lens-subject distance. The actual focusing operation is of course performed by observing the reflex image in the camera, which can be swung from a vertical to a horizontal format or vice versa in one single movement. When using the Swing Angle Attachment in the horizontal position, it may simply be placed on a table.

Order numbers:

Focusing Slide (a) alone 155.01 U7
Swing Angle Top (b) alone. 155.03
Compl. Swing Angle
Attachment (a + b) 155.08

When ordering either the Swing Angle Top or the complete Swing Angle Attachment, always state whether the camera with which it is to be used has an English or Continental tripod thread.

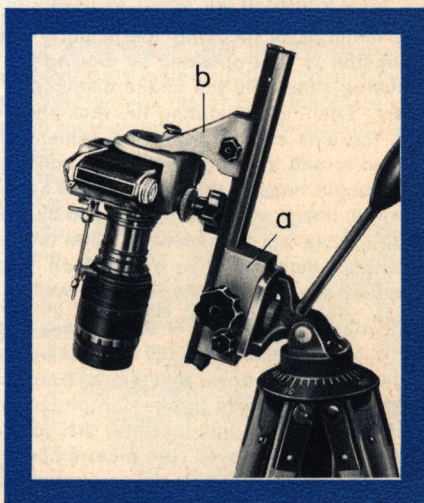

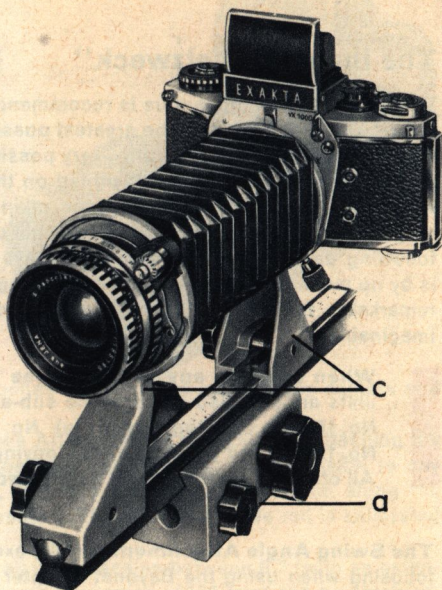

The Bellows Attachment is intended for use with a static subject and stationary camera, and is designed for the most efficient close-up photography of the very smallest objects. The bellows extension is continuously adjustable between 35 and 220 mm, providing a speedy means of varying the image distance—and consequently the image scale—over a wide and unbroken range. The unit can be fitted to a tripod either horizontally or (with the aid of a pan-and-tilt head) vertically. A rotating attachment ring permits the camera to be used in any desired position. It can safely be turned and arrested at any angle (for exposures having vertical, horizontal or oblique format). When used horizontally, the Bellows Attachment may be simply placed on a table-top. There are two methods of focusing (particularly when employing a tripod): the required bellows extension is first obtained by moving the camera standard along the guide rail of the focusing slide until the image distance is adjusted so as to provide the desired image scale. Then, by operating the rack-and-pinion wheel of the focusing slide, the guide rail, the lens standard and the camera standard of the Bellows Top Attachment are moved to and fro as a single unit until the reflex image appears sharp in the viewfinder. If it should happen that the distance between the lens and the subject cannot be varied, then the image may also be focused by moving the camera standard alone; the resulting image scale will then depend upon the lens-subject distance. The amount of bellows extension employed can be read off from the scale on the guide rail. Both the lens standard and camera standard as well as the guide rail can be locked in any position.

With standard lenses ($f = 50$ mm), any image scale between $\times 0.7$ (= extension 35 mm) to $\times 4.4$ (= extension 220 mm) can be achieved, and subjects covering areas from 34 mm \times 51 mm down to 5 mm \times 8 mm can be photographed so as to fill the negative frame. If it is desired to photograph larger subjects in entirety and to extend the focus-distance range to infinity, then the special lens T f 2.8/50 mm with sunk mount, from Jena, can be employed (see picture above, left). The extension range available with this lens is from 0 to 185 mm; the amount of extension can be read off from the second (red) scale on the guide rail.



Order numbers: Focusing Slide (a) alone	155.01 U7
Bellows Top Attachment (c) alone	155.02
Complete Bellows Attachment (a + c)	155.10
Special lens T f 2.8/50 mm with sunk mount, from Jena	128

The Transparency Copying Equipment provides a most useful extension to the Bellows Attachment, enabling it to be used for making transparencies from 24 mm x 36 mm monochrome and colour negatives and also intermediate negatives from 35 mm reversal slides. This copying operation is performed optically, by using the accepted close-up techniques for photographing at an image scale of $\times 1.0$ (1 : 1); selected smaller sections of the original can also be copied. The Bellows Attachment, with the Transparency Copying Equipment in position, can either be placed on a table or fitted horizontally to the column of the Repro Unit or Copying Stand. Special features of this equipment are: film carrier suitable for either single negatives and transparencies or for film strips, and picture gate with adjustable rise and fall for selecting sections of the image. With drop-in frame for 5 cm x 5 cm mounted transparencies, opal screen for uniform light distribution, pressure plate for holding the original flat and special copying shield to exclude unwanted straylight.

The Transparency Copying Equipment is supplied with a focusing screen for setting-up the apparatus and two masks for single negatives or transparencies.

Order numbers:	
Bellows Attachment (a + c) alone	155.10
Transparency Copying Equipment (d)	155.04
Complete Transparency Copying Attachment (a + c + d)	155.19

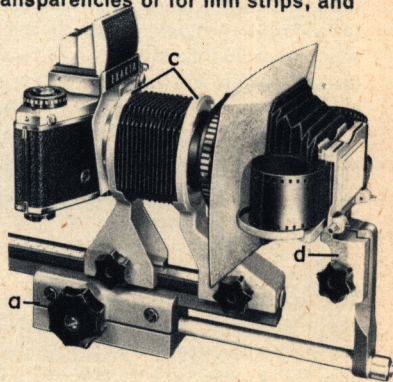



The Copying Stand and Repro Unit are specially designed for the rapid and trouble-free copying of flat originals, such as paintings, drawings, book and magazine illustrations, documents, etc. These units are also invaluable for taking close-up pictures of stamps, coins, and in fact of any small objects. They are generally employed with the camera pointing vertically downwards, but can also be attached horizontally so that the Copying Stand performs the role of a steady table tripod. An illuminator may be placed on the baseboard of the Copying Stand or Repro Unit, allowing translucent originals to be photographed by transmitted light when the camera is used pointing downwards; a combination of transmitted and reflected light may also be employed. The illuminator-technique can likewise be used for making miniature transparencies from large-format negatives. The Copying Stand (see two top pictures on page 11) is designed for supporting the camera directly without any intermediate attachments; the additional lens extension needed for close-ups can be obtained by means of the Bayonet Adapter Rings and Extension Tubes, or by using the Miniature Bellows Attachment. The Repro Unit, on the other hand (see bottom right-hand picture on page 11) already incorporates the Bellows Attachment, the use of which is described on page 8. The Repro Unit can also be employed for photomicrography; further details are given on page 28.

Both the Copying Stand and Repro Unit have the following features in common: precision-turned metal column with its own rack-and-pinion drive for elevation adjustment, large control knob and universal pivoted camera holder for changing instantly from vertical to horizontal pictures and vice-versa when using the camera in a horizontal attitude. With rotating all-metal column allowing the camera to be swung round through 180° to the rear for photographing larger subjects at a greater distance, over the edge of the table (as when the original is laid on the floor). Locking screws are provided on the column, elevation-adjustment sleeve and camera holder. Wooden baseboard 13½ × 20 inches (34 cm × 50 cm) in area, suitable for originals up to A 4 size (8¼ × 11¾ in. approx.). Metal angle-bracket for attaching the camera in a horizontal attitude. If required both the Copying Stand and the Repro Unit can be fitted with a Lighting Equipment.

Order numbers: Bellows Attachment (a + c) alone	155.10
Copying Stand (e) alone	155.16
Repro Unit (a + c + e)	155.20

The Lighting Equipment for the Copying Stand and Repro Unit (see bottom right-hand illustration, page 11) will provide even illumination for originals to be copied or for photographing any small objects at a close distance. The Equipment is slid on to the lower part of the metal column and can be locked at any desired height. The pivoted reflectors

and flexible arms allow the lamps to be adjusted so as to provide the most efficient illumination of the original.

Order number:

Lighting Equipment (f) for Copying Stand and Repro Unit 213.12

The Tripod Plate (see bottom left-hand illustration) has been designed especially for use with the Swing Angle Top. When using a camera with a long-focus or other heavy lens (which does not have a tripod bush of its own), particularly in combination with Bayonet Adapter Rings and Extension Tubes, the centre of gravity of the whole apparatus often becomes unbalanced. Even when employing a tripod this can lead to unsteadiness and vibration. The purpose of the Tripod Plate is to restore the equilibrium of the camera. The camera is screwed to the upper component of the Swing Angle Top (see page 11), which in turn is then slid on to the short guide rail of the Tripod Plate and moved sufficiently to the rear of the central vertical axis of the tripod. In addition, this movement will often be found very useful in close-up photography, in that it allows the subject distance to be varied even when the tripod position cannot be altered. The Tripod Plate is provided with English and Continental tripod threads ($\frac{1}{4}$ " and $\frac{3}{8}$ "). The Swing Angle Top makes it possible to swing the camera from the horizontal-format position to the vertical or vice-versa in one simple operation.

Order numbers:

Tripod Plate (g) alone 155.13

Swing Angle Top (b) alone 155.03

When ordering the Swing Angle Top, always specify whether the camera in question has an English or Continental tripod bush.

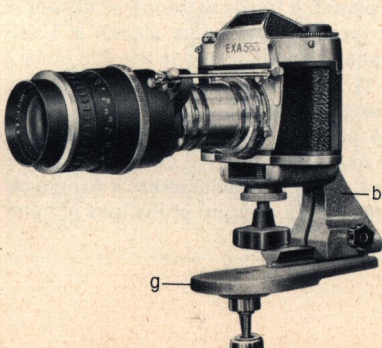
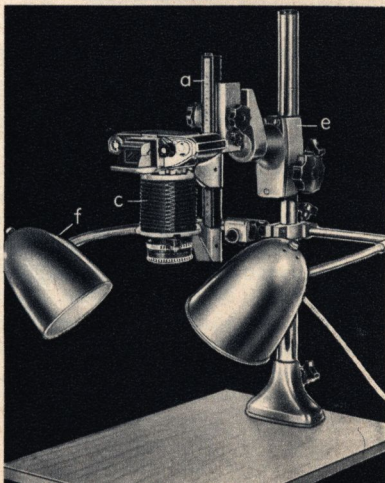
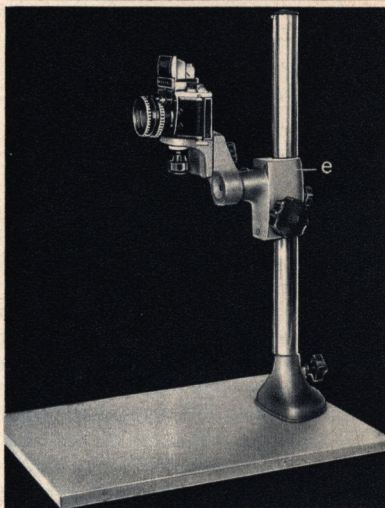
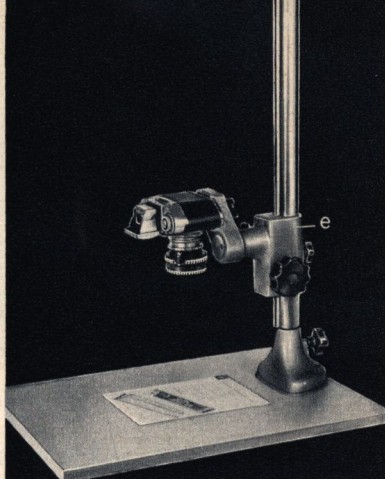

What extension increase is required?

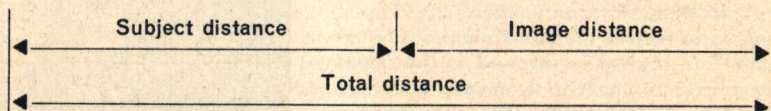
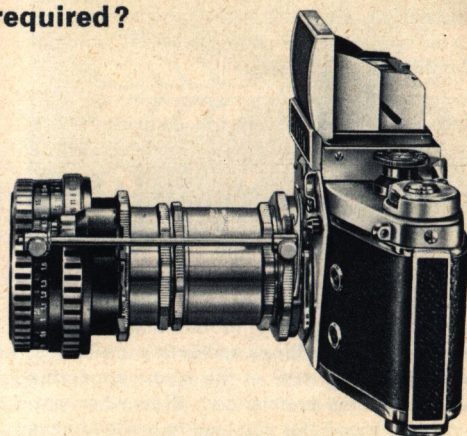

The table on the opposite page shows the relevant focusing data and scales of reproduction obtained with lens extensions from 5 to 220 mm. When using the Bellows Attachment (even with the special lens T f 2.8/50 mm with sunk mount, from Jena) these are set according to the scales. The Bayonet Adapter Rings and Extension Tubes can be used in any desired combination, enabling the requisite increase in extension to be adjusted in 5 mm steps. The figures in the table are calculated for a lens-focus setting of ∞ ; when using the Bayonet Adapter Rings and Extension Tubes intermediate values can be obtained by means of the helical focusing movement. The long travel of the camera-lens focusing movement thus provides certain facilities for overlapping, which can often prove very useful. If it is required to obtain a considerably enlarged image of the subject on the negative, then it will be necessary to use two or even more sets of Bayonet Adapter Rings and Extension Tubes. The table contains calculated values, which may differ slightly from the actual values obtained with specific lenses as a result of the permissible tolerances in focal length.

Explanation of the data in the table:

- Extension increase = overall length of Bayonet Adapter Rings and Extension Tubes or bellows extension employed.
- Subject distance = distance between the subject to be photographed and the lens (approx. diaphragm plane).
- Image distance = distance between the image in the film plane and the lens (approx. diaphragm plane).
- Total distance = distance between the subject photographed and the image in the film plane.
- Image scale = ratio of image size to subject size ($1 : 1 = 1.0 =$ subject and image are of equal size; $1 : 2 = 0.5 =$ the image is only half as large as the subject; $2 : 1 = 2.0 =$ the image is twice as large as the subject, two times enlargement).
- Area of coverage = breadth and length of original which will fill the negative frame (= coverage of subject area). The sum of the values here are rounded up to full millimetres.
- Exposure factor = factor by which the exposure must be increased on account of the loss of light through increasing the image distance.

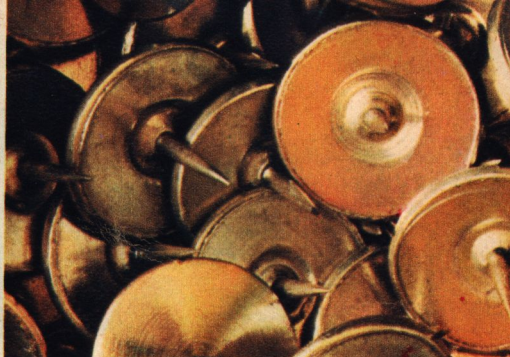

Close-up focusing table for lenses with focal length 50 mm

Extension increase mm	Subject distance mm	Image distance mm	Total distance mm	Scale of reproduction	Area of coverage mm × mm	Exposure factor
5	550	55	605	0,1	240 × 360	1,2
10	300	60	360	0,2	120 × 180	1,4
15	217	65	282	0,3	80 × 120	1,7
20	175	70	245	0,4	60 × 90	2,0
25	150	75	225	0,5	48 × 72	2,3
30	133	80	213	0,6	40 × 60	2,6
35	121	85	206	0,7	34 × 51	2,9
40	113	90	203	0,8	30 × 45	3,2
45	106	95	201	0,9	27 × 40	3,6
50	100	100	200	1,0	24 × 36	4,0
55	95	105	200	1,1	22 × 33	4,4
60	92	110	202	1,2	20 × 30	4,8
70	86	120	206	1,4	17 × 26	5,8
80	81	130	211	1,6	15 × 23	6,8
90	78	140	218	1,8	13 × 20	7,8
100	75	150	225	2,0	12 × 18	9,0
110	73	160	233	2,2	11 × 16	10,2
120	71	170	241	2,4	10 × 15	11,6
130	69	180	249	2,6	9 × 14	13,0
140	68	190	258	2,8	9 × 13	14,4
150	67	200	267	3,0	8 × 12	16,0
160	66	210	276	3,2	8 × 11	17,6
170	65	220	285	3,4	8 × 11	19,4
180	64	230	294	3,6	7 × 10	21,2
190	63	240	303	3,8	6 × 9	23,0
200	63	250	313	4,0	6 × 9	25,0
210	62	260	322	4,2	6 × 9	27,0
220	61	270	331	4,4	5 × 8	29,0



Lens Reversal Ring

In order to obtain close-ups which result in a considerable enlargement of the subject on the actual negative, it is necessary to provide a relatively great image distance and a correspondingly short subject distance. Normal camera lenses are, however, corrected to provide optimum definition under the reverse conditions, i.e. a short image distance and a large subject distance. When maximum definition is required in close-ups in which the subject is to appear magnified by more than 1.5 times on the negative, it is, therefore, advisable to mount the lens with its rear element facing the subject. The Lens Reversal Ring is provided for this purpose. This permits the camera lens to be screwed back to front on to the foremost extension tube. When using the Bellows Attachment the rear Bayonet Ring of the set of two must be used as an adapter: it is fitted into the lens standard and the reversed lens is screwed on to it. (When a camera lens is used reversed, it is then impossible to employ the helical focusing movement. In addition, the extension will vary to an extent which depends upon the type of lens and cannot be allowed for in tables.)

Order numbers: Lens Reversal Ring for lenses with screw-in filter thread

M 35.5 × 0.5 mm	159/37
M 40.5 × 0.5 mm '	159/42
M 49 × 0.75 mm	159/51

Adapter Ring for Photomicrographic Lenses

For taking pictures at an image scale of more than, $\times 5.0$, photomicrographic lenses specially designed for extreme close-up work (such as the "M from Jena") should be employed instead of the camera lens, even if this is reversed. An adapter ring is available

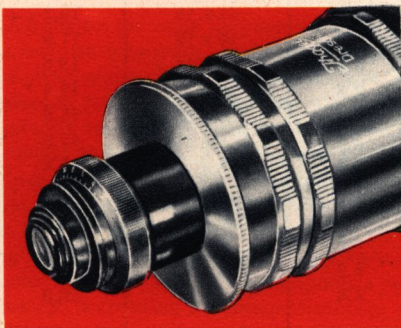

with a screw-in thread for accepting these lenses. The adapter ring is screwed into the front extension tube. When using the Bellows Attachment the rear bayonet ring is first fitted on the lens standard, and then the adapter can be screwed into the bayonet ring.

Order numbers:

Adapter Ring for photomicrographic lenses with international microscope-lens thread W 0.8" × 1/36"	193/1
Adapter Ring for photomicrographic lenses with M 26.5 × 0.5 mm thread ("M from Jena")	193/2

Front Bayonet Adapter Ring with Outer Bayonet

When using long-focus lenses with outer bayonet mounts in conjunction with the Bayonet Adapter Rings and Extension Tubes, the front Bayonet Ring must likewise be fitted with an outer bayonet. This ring is available separately. If these same lenses are employed with the large Bellows Attachment, fit the normal rear Bayonet Ring to this special front ring and attach the lens to the lens standard of the Bellows Attachment by means of this pair of Bayonet Adapter Rings. Always ensure that a steady support is provided for the camera when fitted with a heavy lens in addition to the Bellows Attachment.

Order number: Front Bayonet Adapter Ring with Outer Bayonet 192

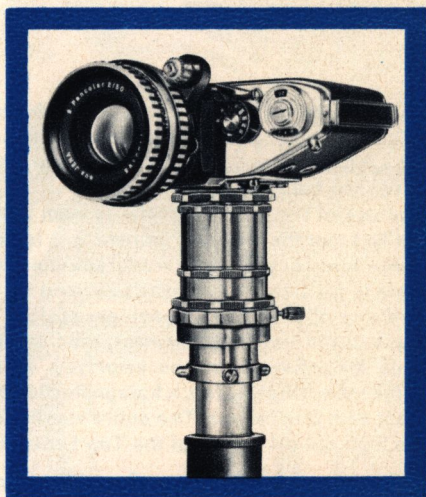
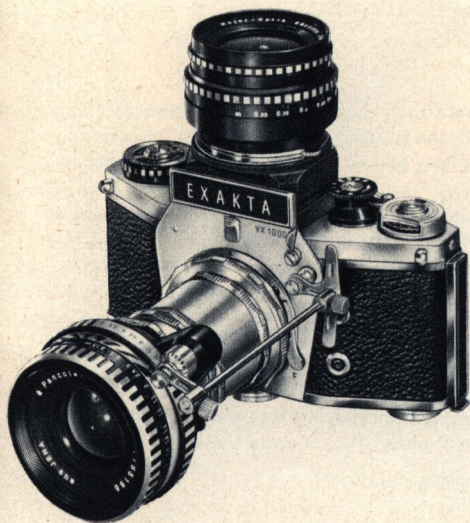

Lens Magnifier and Top Lens

The Lens Magnifier provides the critical exactitude of focusing which is so important in close-up and photomicrographic work. This attachment enables one of the highly corrected standard or special-purpose camera lenses to be used (focused to infinity) as a magnifying lens for viewing an enlarged, virtually distortion-free viewfinder image that is uniformly sharp from one edge to the other. If the eye is held close to the front element, then the whole reflex image will be visible with lenses of $f = 50$ mm and above. The shorter the focal length of the lens, the greater will be the magnification of the reflex image; however, it will only be possible to see the centre of the field when employing a wide-angle lens. The effective magnification of the lens can in any event be increased still further by holding a small pocket magnifier (such as the $\times 2,5$ magnification Tellup) over the camera lens which is being used as a magnifying focusing aid. This will provide the following values:



Magnification of the focusing image

including that provided by the ground- or clear-glass focusing screen

with f = 35 mm Lens	× 8.1
with Tellup	× 20.3
with f = 50 mm Lens	× 5.7
with Tellup	× 14.3
with f = 100 mm Lens	× 2.8
with Tellup	× 7.0
with f = 135 mm Lens	× 2.1
with Tellup	× 5.3

The Lens Magnifier can be fitted on the camera in place of the Finder Hood or Penta Prism and can be employed in conjunction with the ground-glass screen of these focusing systems as well as with the plane ground-glass screen and special focusing screens described below.

The use of the Lens Magnifier is even more practical in photomicrography, because of the fact that the standard camera lens is not required for photographing the microscope image and is, therefore, made available for use as a focusing magnifier. If, however, there is no suitable lens ready to hand for this purpose (when taking normal close-ups) or if one of the earlier-model lenses does not permit the eye to be brought sufficiently close to the front lens element, then the Top Lens specially designed for use with the Lens Magnifier should be employed. In conjunction with the ground- or clear-glass screen this will provide a $\times 5$ magnification of the reflex viewfinder image (or $\times 12.5$ enlargement with the Tellup). The entire viewfinder image can then be seen at a glance, whilst the high optical quality of the Top Lens ensures extremely accurate focusing.

Order numbers: Lens Magnifier with ground-glass screen 308.01
 Top Lens 312

Plane Ground-Glass Screen

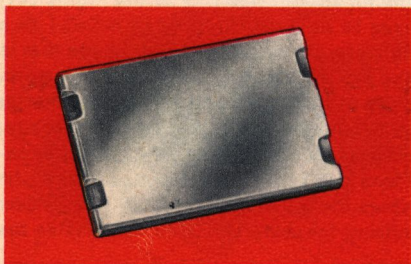

A plane-surfaced ground-glass screen is available for adjusting the image framing without the distraction of a convex focusing lens; this is often useful in copying work, etc. If desired, the focusing screen can be obtained with centimetre or millimetre divisions, right-angle guide lines, etc. The Plane Ground-Glass Screen may be employed in the current Finder Hood, in the Penta prism, and in the Lens Magnifier.

Order number: Plane Ground-Glass
 Screen 308.22



Special focusing screens for close-ups, photomicrography, and astro-photography

Besides providing interchangeable viewfinder units, the multi-purpose EXAKTA allows the focusing screen to be selected to suit the requirements of specialized types of work. In ultra-close-up photography, photomicrography, and astro-photography it is frequently desirable to view the image on the matt surface of the focusing screen and at the same time to focus the image critically upon the finest detail of the subject by means of the more brilliant aerial image, without the distraction of the screen grain-pattern. For this reason focusing screens are available with a clear centre spot and hairline cross; the aerial image may be viewed through the clear centre spot and the hairline cross obviates the after-accomodation of the eye. It is, of course, also possible to employ an unground, completely clear glass (also with hairline cross) for focusing in these particular fields. These special focusing screens are, as already mentioned, suitable only for extremely close-up work in which a very short lens-subject distance is involved (this also includes endoscopic photography and spectroscopic photography), and in photomicrography and astro-photography. They are not, however, suitable for taking pictures at more normal subject distances (landscapes, architectural photographs, portraits, etc.); for these the use of the Fresnel lens is recommended (see page 31)

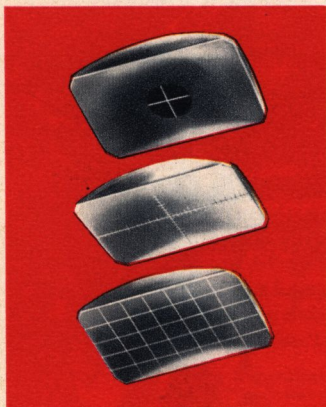

Order numbers:

Special focusing screen for the current Finder Hood, the Penta Prism and the Lens Magnifier

Ground Glass with 3 mm \varnothing clear centre spot and hairline cross 302.03

Ground Glass with 10 mm \varnothing clear centre spot and hairline cross 302.04

Clear Glass with hairline cross 302.10

Ground Glass with hairline cross and millimetre graticule 302.05

Special large focusing screens for earlier models of the Finder Hood (with frame finder); for exchanging these screens, loosen the retaining screws on the shorter sides of the Finder Hood

Ground Glass with 3 mm \varnothing clear centre spot and hairline cross 301.03

Ground Glass with 10 mm \varnothing clear centre spot and hairline cross 301.04

Clear Glass with hairline cross 301.10

Ground Glass with hairline cross and millimetre graticule 301.05

Both types of these special focusing screens can be supplied in other forms (e.g. with right-angle guide lines, etc.) to special order.

Ihagee Macro-Micro Photometer

Determining the exposure required with a standard exposure meter is often either difficult or completely impossible in close-up photography or photomicrography. Experience has, however, revealed that the only effective method of obtaining the required exposure times, aperture settings or illumination intensity is to measure the actual image-forming light inside the camera. This is the function of the Ihagee Macro-Micro Photometer.

In close-up work, this unit is attached between the camera body and the lens, and for photomicrography between the camera body and the microscope eyepiece; in both cases it is fitted immediately in front of the front plate of the camera. There is a standard lens-

mount bayonet on the side of the Photometer which faces towards the subject.

The Photometer itself provides an effective lens extension of 20 mm, which must be allowed for in determining the final image scale, etc. For measuring the intensity of the light actually involved in creating the image in the camera, a selenium barrier-layer cell is lowered into the beam of light passing through the lens; during this procedure the shutter release button of the EXAKTA or EXA remains locked to prevent the shutter being released accidentally. Before taking the picture the selenium cell is removed from the path of the image-forming rays and the release button is thereby freed.

The selenium barrier-layer cell converts the luminous energy into an electrical current in the normal way, and this can be measured with the aid of a standard micro-ammeter or luminous-spot galvanometer with an effective range of 5 . . . 30 μ A, internal resistance 1000 . . . 5000 ohms. The connection between the Ihagee Macro-Micro Photometer and the meter is provided by a cable, for which there are two connection sockets on the Photometer panel. To evaluate the meter readings, it will be necessary to make a series of trial exposures over a progressive range of exposure settings; these can then be used as reference data for future work, since provided that the same type of film is employed, any given meter deflection will indicate that the same exposure settings should be employed. Fine adjustments to balance the meter reading can be made by altering the lens aperture or the intensity of the light source.

The Ihagee Macro-Micro Photometer provides the ideal method of exposure measurement for all branches of photomicrography, for close-up photography of stationary subjects, and for optical copying of transparencies, etc. When used as described in conjunction with a micro-ammeter or luminous-spot galvanometer it eliminates the need for all calculation, since the exposure-increase factors involved in close-up work with extension tubes, etc. are automatically allowed for.

Order number:

Ihagee Macro-Micro Photometer 167

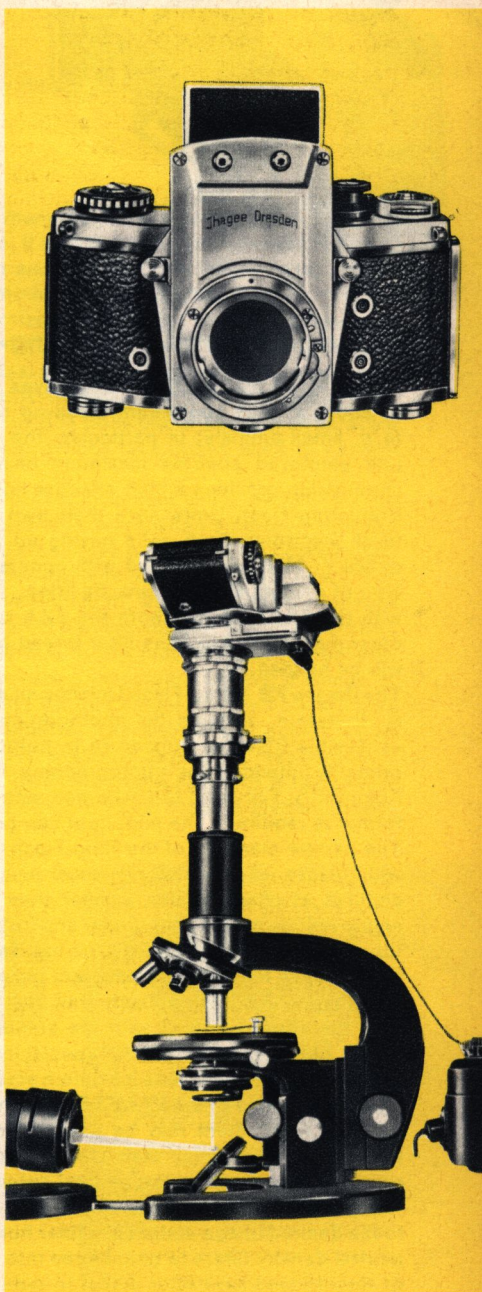

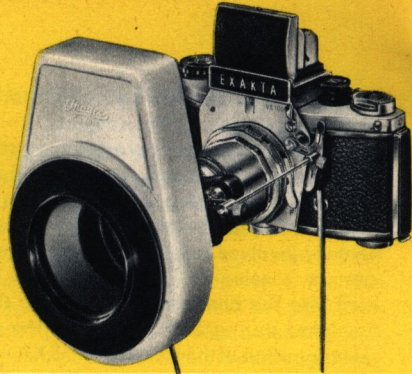
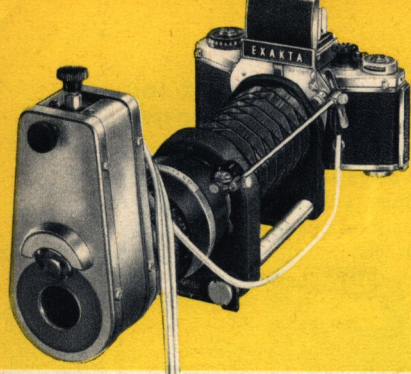

Ihagee RB 1 and RB 2 Ring-Flash Units

can be used for practically every type of close-up photography and make it possible to adopt a most convenient close-up technique. When photographing living subjects (e.g. small animals) in particular, the very brief flash duration of the electronic flash unit employed ensures maximum image sharpness. The constantly-uniform frontal illumination provides a high effective light output and gives almost shadowless lighting. Both Ring-Flash Units have their own triggering mechanisms and can be connected to all electronic flash units having up to 250 joules output, with an operating voltage of 500 V. They are supplied with connecting cables, but without plugs; the appropriate type of plug must, therefore, be fitted. The RB 1 and RB 2 Ring-Flash Units can be used with the EXAKTA and both the EXA models, as well as with miniature cameras from other manufacturers (lens filter thread M 49 × 0.75 mm); with other lenses, adapter rings will be needed.

The Ihagee RB 1 Ring-Flash Unit has an annular flash tube of relatively small diameter, and is, therefore, suitable for photographing the interiors of hollow vessels which are accessible from the outside (e.g. bottles, jugs, tubes, cylinders, etc.). It is, however, primarily intended for photographing human and animal body cavities (see "Ihagee Kolpofot"). Focusing is performed with the aid of the 6 V pilot light, for which a transformer is required. The pilot light can be adjusted in all three planes.

The narrow diameter of the Ring-Flash tube means that the RB 1 can only be employed with lenses of 100–135 mm focal length, and also that it cannot be used for taking pictures at image scales smaller than 0.5. The usual extension accessories may be employed (e.g. bayonet rings and tubes, or bellows attachments). The light-baffle tube of the RB 1 Ring-Flash Unit has an M 24 × 0.5 mm screw thread for filters, photomicrography lenses, etc.; adapters must be used for filters with different threads.

The Ihagee RB 2 Ring-Flash Unit has an annular flash tube of larger diameter, and can, therefore, be used with the standard lenses of miniature cameras, having a focal length of 50 mm and also with special lenses of slightly longer focal length up to approx. 135 mm (with a 50 mm lens maximum scale of reproduction × 1.0). From the range of extension accessories of the EXAKTA-System the bayonet rings and tubes as well as the large Bellows Attachment may be employed. In addition, screw-in close-up lenses may be used. The RB 2 Ring-Flash Unit is not designed for photographing the interior of cavities, but mainly for the general spheres of close-up work. For this reason the design has been kept somewhat simplified (e.g. no pilot light). In order to adapt the illumination to the desired image distance, a filter holder is available. It permits commercially available neutral density filters to be inserted into the light path (screw-in thread M 58 × 0.75 mm), or ring-shaped grey filter discs, to reduce the effective light intensity of the flash tube.

Order numbers:

Ihagee RB 1 Ring-Flash Unit	196
Ihagee RB 2 Ring-Flash Unit	197
Filter holder for RB 2 with 2 grey filter discs	197.030.00
Ring-shaped grey filter discs	197.030.04

Ihagee Kolpofot

The Ihagee Kolpofot has proved invaluable in many fields of scientific and technical photography, and particularly in medical practice. It provides a most convenient method of taking pictures of eyes, skin conditions, teeth and ears, etc. The Kolpofot is, however primarily employed for photographing the interior of body cavities (vagina, mouth, pharynx, etc.). There already exist well-documented cases of the most important role played by the Kolpofot in controlling cancer in the mouth of the uterus, since despite its remarkable simplicity of operation, intravaginal pictures taken with this apparatus reveal the very finest structures with such clarity of detail that they are entirely adequate for diagnostic purposes. With the Kolpofot it is possible to perform large-scale examinations in a similar manner to the mass fluoroscopy techniques used to combat pulmonary tuberculosis.

The Bellows Attachment is used for focusing to obtain maximum image definition. The EXAKTA can be employed for every type of colposcopic work when employed with the Penta Prism, fitted with a clear-glass with hairline cross (see page 18). This combination provides a relatively brilliant reflex image even when the lens is stopped right down. For focusing, the subject is illuminated by means of the pilot light, whilst the actual exposure is made with the ring-flash tube synchronized with the camera shutter; the brief duration of the flash obviates any danger of unsharpness due to the movement of the patient. The S f4/135 mm long-focus lens from Jena provides a favourable subject distance of about 20 cm (8 in.) and in combination with the long bellows extension available will give up to $\times 1.6$ enlargement of the original on the negative. The subject will appear up to 7 times life-size in the Penta Prism of the EXAKTA, ensuring immediate recognition of structural details even in the most critical cases. The lens of the Kolpofot S f4/135 mm from Jena with pre-set diaphragm may be stopped down to f45 in order to provide exceptional depth of field.

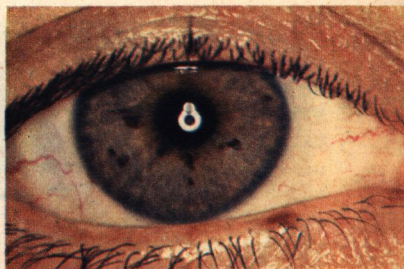
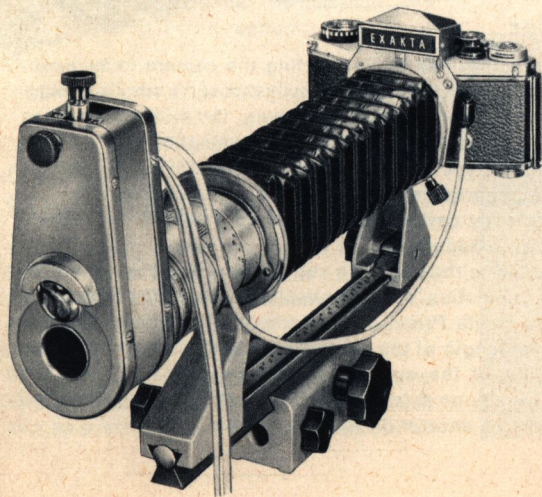

Additional equipment required for working with Ihagee Kolpofot comprises: a sturdy tripod with universal pan-and-tilt head, an electronic flash unit (speedlight) with a nominal output of 500 W and a 6 V transformer or accumulator for the pilot light.

Order numbers: Ihagee Kolpofot, complete, comprising Bellows Attachment,
 S f 4/135 mm lens with pre-set diaphragm, from Jena stopping
 down to f 45, RB 1 Ring-Flash Unit with pilot light and cable 155.11
 S f 4/135 mm lens with pre-set diaphragm, from Jena stopping
 down to f 45 alone 437 A
 RB 1 Ring-Flash Unit with pilot light and cable alone 196

On request, the Ihagee Kolpofot may be fitted with the S f 4/135 mm lens, from Jena (with fully-automatic diaphragm stopping down to f 22). The fully-automatic diaphragm of this lens necessitates the use of a double cable release.

Order numbers: Complete Ihagee Kolpofot, equipment as above but with
 S f 4/135 mm lens, from Jena (with fully-automatic diaphragm
 stopping down to f 22) 155.11FAD
 S f 4/135 mm lens, from Jena (with fully-automatic diaphragm
 stopping down to f 22) alone 637

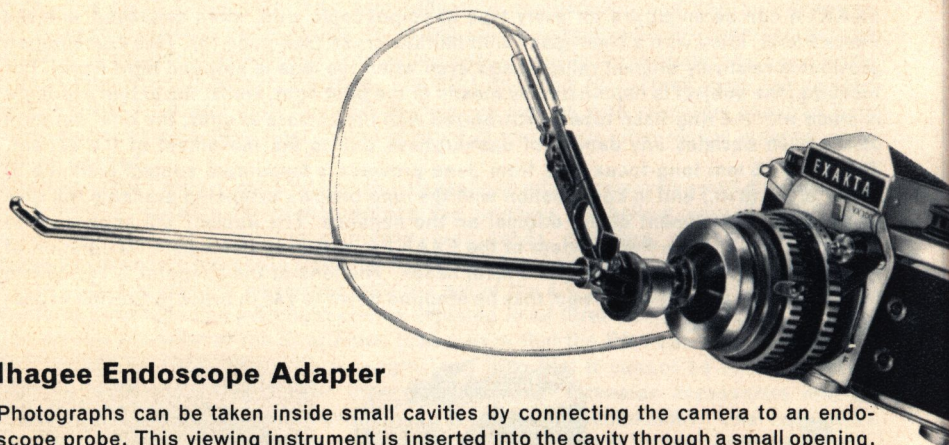

Ihagee Endoscope Adapter

Photographs can be taken inside small cavities by connecting the camera to an endoscope probe. This viewing instrument is inserted into the cavity through a small opening. The picture is taken at an angle of 90° to the direction of viewing, the endoscope being fitted with a small incandescent lamp to provide the necessary illumination of the object under examination. Photographs of this type are often useful in technological, artistic, and scientific investigations, and are of particular importance in medicine whenever it is necessary to record the interior of a body cavity which is not accessible from outside (for example, the interior of the human bladder).

If the lens of the EXAKTA is connected to the eyepiece cup of the endoscope, then the reflex image of the object under examination can be observed, laterally correct and without parallax displacement, in the Penta Prism of the camera. The diameter of this circular image depends upon the focal length of the camera lens and will become larger with longer-focus lenses. The design of the endoscope will determine whether the camera lens should be focused to infinity or if (even with Bayonet Adapter Rings and Extension Tubes) it must be focused to a shorter distance.

A special Endoscope Adapter is available for connecting the lens of the EXAKTA to the eyepiece cup of the endoscope; to ensure an accurate fit, these are manufactured individually to match the dimensions of the instrument involved. It is recommended that the endoscope (or at least the eyepiece cup) should be sent in to the factory so that a precise fit can be ensured. If this is not possible, full details must be provided, giving the dimensions "a" to "h" as shown in the diagram.

The Adapter consists of two components which are screwed together to clamp the eyepiece cup firmly in position. The connection between the Adapter and the lens of the EXAKTA is provided by a quick-release flange which also allows both the camera and the endoscope to be rotated independently of each other. When ordering an Endoscope Adapter it is also necessary to quote exactly the type of lens with which it is to be used (e.g. T lens f 2.8/50 mm, from Jena, with fully-automatic spring diaphragm). In place of the usual ground-glass screen, a special clear glass is employed in the Penta Prism of the EXAKTA. This type of focusing screen makes it possible to focus on the more brilliant aerial image, in which even the finest details can easily be distinguished.

If you have any further questions concerning the use of the EXAKTA in endoscopic photography, additional information will gladly be supplied on request.

Order number:

Ihagee Endoscope Adapter 189

Overrunning Switch Apparatus

In endoscopic photography it is important to provide the highest possible intensity of illumination during the actual exposure. To achieve this it is possible to overrun the small lamp used in the endoscope for a brief period. For example, if a 12 volt lamp is employed for medical endoscopy, this may be overrun at 24 volts during the period

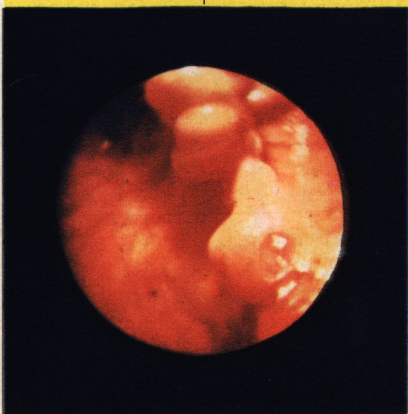
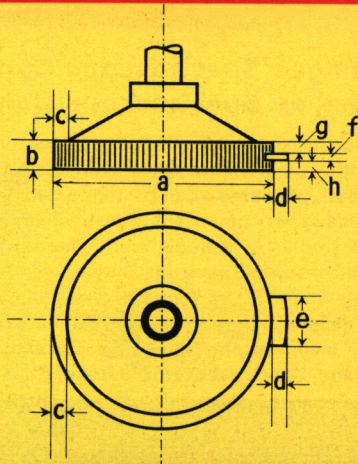

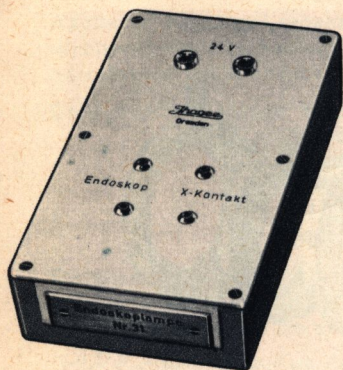

of exposure. The Overrunning Switch Apparatus is designed for use in conjunction with the EXAKTA Varex IIa, IIb, and EXAKTA VX1000 to effect this switchover automatically; it is connected to the X-contact of the camera. A 24 V source of current is required, whilst a 12 V tungsten lamp is fitted in the endoscope. During the preparatory stages the lamp is run on an 8 volts supply only, whilst during the exposure the voltage is raised momentarily to 24 V without giving it time to damage the lamp.

If the Overrunning Switch Apparatus is employed with any other type of endoscope lamp, then the operating voltage and amperage of the lamp should be quoted, together with the voltage of the power supply, so that an appropriate resistance may be fitted.

Order number:
 Overrunning Switch Apparatus 177

Ihagee Spectroscope Connecting Ring and Ihagee Spectroscope Connecting Shell

Spectroscopes too belong to the group of optical viewing instruments, to which the three single-lens reflex cameras of the EXAKTA-system – preferably the EXAKTA itself, of course – can be connected, in order to record the results by photographic means. This is very important in many fields of research, in industrial- and hospital-laboratories, as well as in schools and colleges, so that the established appearances of absorption- and issuing-spectrons may be made visible again at any required time. For two well-known makes of Spectroscopes simple connecting pieces have been produced.

The lens of the EXAKTA, when focused for infinity and with its aperture fully opened, may, by means of the Ihagee Spectroscope Connecting Ring, be attached to the well-known Hand-Spectroscope from Jena. So that the resulting spectrum, including the wavelength

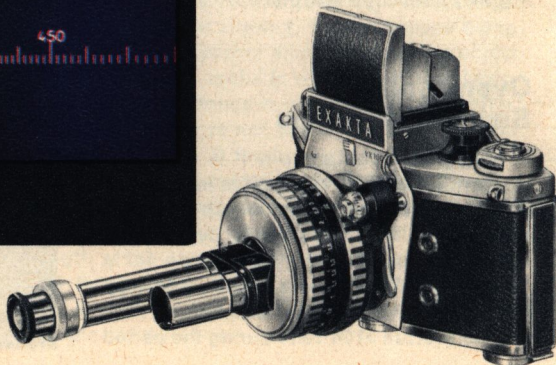
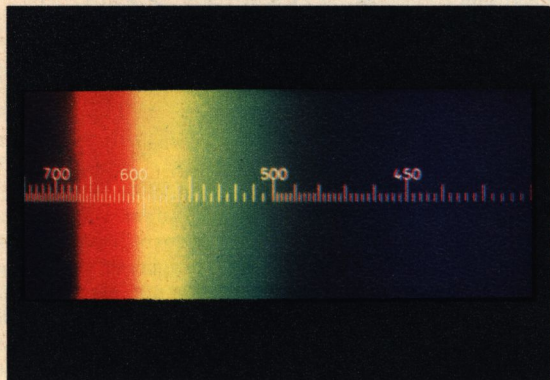

scale may be reproduced on a sufficiently large scale, it is recommended to employ the special long focal length S 4/135 mm lens from Jena. The Ihagee Spectroscope Connecting Ring is designed to fit the M 49 \times 0.75 lens front thread and the M 14 \times 0.5 thread of the Jena Hand-Spectroscope. For the greatest ease in focusing the Spectroscope, the viewing system of the EXAKTA should preferably be fitted with the special clear screen with hairline cross (see page 18). In order to establish the composition of metals the ROW-Metal-Spectroscope, manufactured by VEB Rathenower Optische Werke, is frequently employed. For this, too, a connecting piece has been produced: the Ihagee Spectroscope Connecting Shell. This enables the EXAKTA, fitted with the special clear screen with hairline cross, to be coupled to the ROW-Metal-Spectroscope, and so without difficulty to photograph the spectrons of the lightsource. The Ihagee Spectroscope Connecting Shell has a camera connecting thread for the lens front thread of M 49 \times 0.75. In this case the standard lens, set to infinity and with aperture fully open, is employed. The camera can be detached from the Spectroscope by one simple movement with the aid of the quick-change mount.

Order numbers: Spectroscope Connecting Ring for the Jena Hand-Spectroscope 190
Spectroscope Connecting Shell for the ROW-Metal-Spectroscope 191

For Spectroscopes of other origin and construction similar connecting pieces can be manufactured. It is, however, essential to accompany the order with the Spectroscope in question, or to furnish us with particulars, including drawing and all the necessary data.

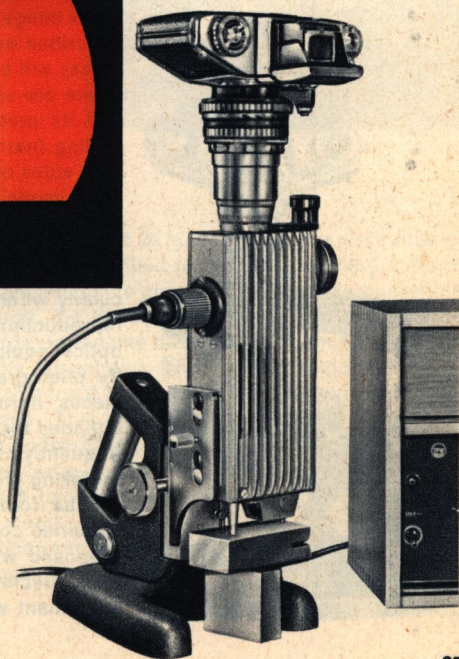
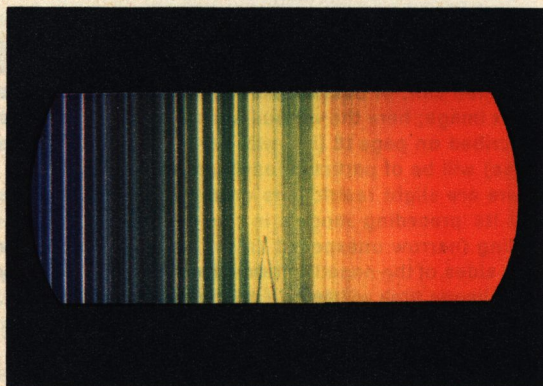

Ultra-close-up-photography with a microscope

Note that close-ups up to an image ratio of approximately $\times 10.0$ can be taken with the aid of a microscope (see illustration below). For further details consult the following sections.

Photomicrography

In the field of photomicrography, Ihagee cameras—the EXAKTA in particular—provide a perfect substitute for other forms of extremely expensive equipment, especially since miniature film provides a most economical means of taking long series of exposures both in monochrome and colour. The camera is attached to the microscope by means of the Microscope Attachment, or is supported above the microscope by the Repro Unit: in both instances the advantages of parallax-free focusing are retained. Normally the camera lens is not employed, the image formed by the objective and eyepiece of the microscope being projected into the camera. The reflex image of the EXAKTA, therefore, makes it possible to control both the correct image area and also the exact moment of exposure—a particularly valuable facility with living specimens. The definition can, of course, likewise be controlled on the reflex image; here the various special focusing screens described on page 18 (i. e. with centre spot and hairline cross) will be of particular assistance.

There are slight restrictions on the use of the EXA Ia and its preceding models in this manner, in that vignetting (narrow unexposed areas) may occur along the long sides of the negative frame. However, a sufficiently large image area will remain unaffected, and, therefore, the EXA Ia and its preceding models are generally suitable for use in photomicrographic work.

Successful photomicrographs generally require—particularly when special emphasis is laid on the scale of reproduction and on uniformity of definition—that the optical equipment of the microscope should be adapted for photographic work. The objective lenses and eyepieces normally used in microscopes are primarily intended for subjective viewing of the specimen and will frequently need to be replaced by more suitable lenses for taking photomicrographs. More detailed information will be found in specialized literature. When making enquiries concerning photomicrography, details of the proposed work should be provided, together with the fullest technical data on the microscope and lighting equipment which is available.

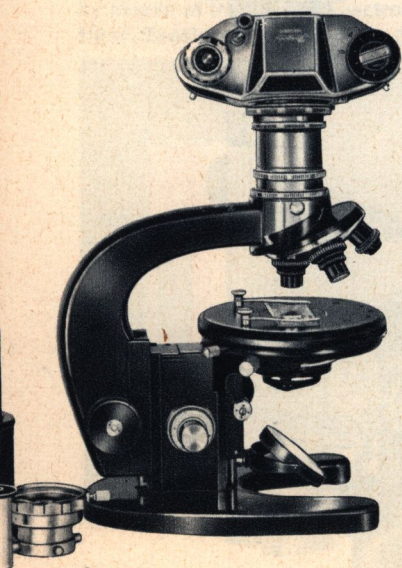

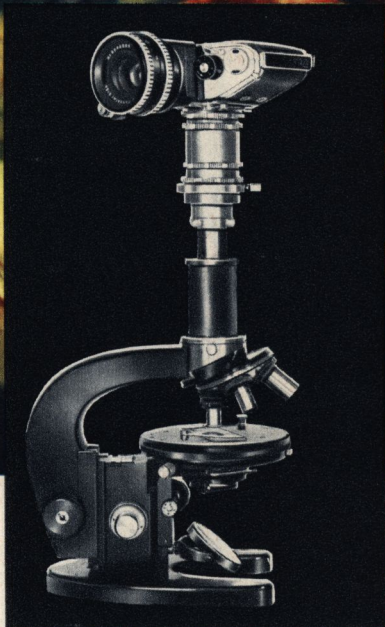

Microscope Attachment

The Microscope Attachment is fitted over the standard 25 mm diameter eyepiece tube of the microscope. The lower part of the adapter is clamped to the tube, exerting uniform pressure on all sides, whilst the camera is placed on the upper component. By slackening the milled screw of the quick-change mount, the upper part can be removed from the microscope together with the camera in order to resume direct visual examination of the specimen, or if photography is temporarily suspended. This upper component of the Microscope Attachment is also designed to accept the quick-change tube mount of the latest Type L and N tube Stands from Jena. This method of working is preferable for taking extreme close-up pictures up to an approximate image scale of $\times 10.0$ (see illustration on page 26). In such cases the tube and eyepiece of the microscope are not employed; a suitable photomicrographic lens is used instead (the M lenses from Jena are particularly recommended for this type of work).

When working with polarized light, the analyser and the requisite compensators can easily be accommodated within the Microscope Attachment.

Order number: Microscope Attachment 153

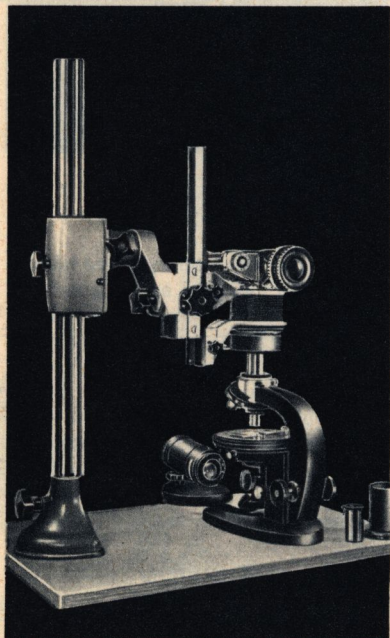
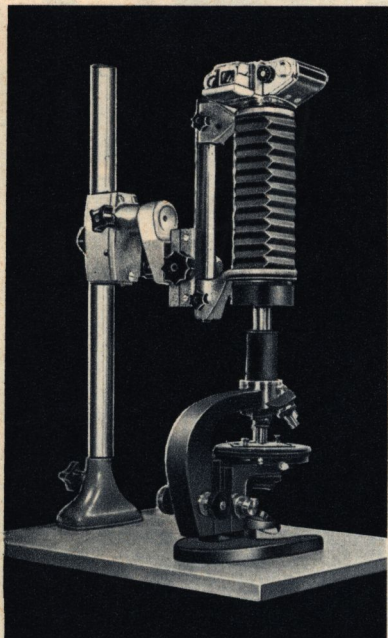

Repro Unit

Many workers, however, prefer not to have a rigid mechanical connection between the microscope and the camera. These users are recommended to employ the Repro Unit, which may be used to hold the camera above the microscope. This form of installation is particularly suitable whenever large degrees of magnification are desired. To exclude straylight two light-baffle tubes are employed, which slide one inside the other without coming into contact with each other. One of these tubes is screwed into the lens standard of the Bellows Attachment, the other (named "light protection sleeve") is pushed over the eyepiece tube of the microscope.

The image scale of the photomicrograph is adjusted by controlling the bellows extension. When photographic work is terminated, all that necessary to do is to raise the complete camera unit slightly by turning the hand-wheel on the column and then swing it to one side. When low magnification eyepieces (up to $\times 10$) are employed in conjunction with wide-aperture objectives, a lack of spherical correction will sometimes be observable. This can be reduced simply by lifting the eyepiece to focus the reflex image in the camera ("eyepiece focusing"). This procedure requires the provision of a Microscope Attachment, which in this case is not clamped to the eyepiece tube. The upper part of the Attachment is locked into the lens carrier of the Bellows Attachment so that it is lifted as the camera is raised, and carries the eyepiece with it.

A special Microscope Ring II is available to facilitate taking ultra-close-up pictures up to an image scale of approximately $\times 10.0$, using the Repro Unit in conjunction with a Microscope Stand Type L or N from Jena. The black microscope tube is then discarded and the eyepiece tube alone employed, on to which the Microscope Ring II is screwed. This ring (with the tube attached) is then inserted directly into the quick-change tube mount of the above-mentioned stands from Jena. The pictures are taken without an eyepiece lens, employing a suitable photomicrographic lens (such as the "M from Jena"); the image

distance and thereby the desired image scale are controlled by adjusting the bellows extension (see lower illustration on page 28).

Order numbers:

Repro Unit	155.20
Light Baffle Tube	156
Light Protection Sleeve	166
Microscope Ring II	157
Microscope Attachment	153

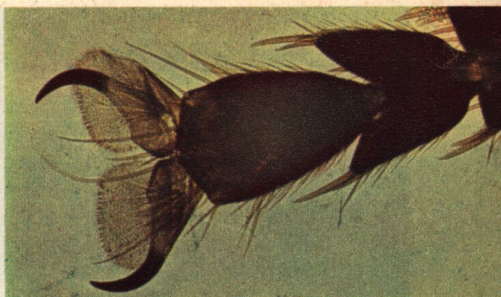

Further accessories for photomicrography

Certain units may also be used for close-up photography and have for that reason been described elsewhere in this manual.

Note particularly

the Lens Magnifier No. 308.01	page 15,
the Top Lens No. 312	page 16,
the Special Focusing Screens	page 18,
the Ihagee Macro-Micro Photometer No. 167	page 18.

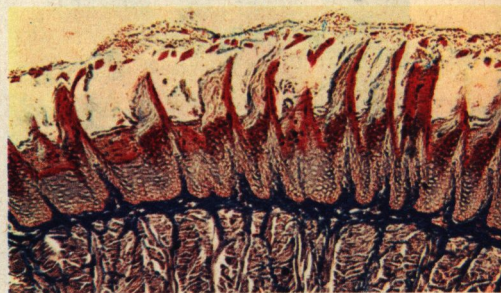

Astro-photography

As already mentioned, the EXAKTA, due to its parallax-free reflex focusing, its simple coupling and the rapid exposure sequence for series of photographs, is ideally suited for use in conjunction with optical viewing instruments. Even the view of the limitless depths of the universe is open to the EXAKTA, when the camera is suitably coupled to a telescope. The main reasons for the suitability of the EXAKTA camera for astro-photography are its following specific qualities: The interchangeability of the viewing systems and, coupled thereto, the possibility of using special focusing screens, in particular the ground-glass screen with clear centre spot (because of the valuable assistance it gives, rendering the viewfinder image exceedingly bright), the long exposure times of up to 6 seconds, which can be employed with delayed action (so that the operator may remove himself from the apparatus during the exposure, in order to avoid camera shake) as well as the stability and precision of the camera in these unavoidable temperature changes, which may be experienced in this type of work.

In astro-photography, as in photomicrography, the camera lens is not used. The image produced by the telescope is projected into the camera. For the subject area covered and for focusing one uses, as always, the parallax-free reflex image.

Telescope Adapter

The telescope adapter enables the EXAKTA to be firmly attached to the telescope. This adapter consists of two parts, which are connected to each other through a quick-change fitting. The camera is attached to the lower part of this adapter by its bayonet ring; the upper part of the adapter is attached to the ocular drawtube by a clamping

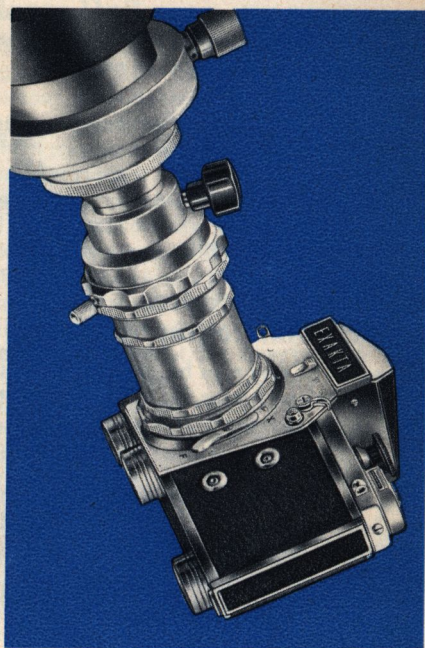

device, the ocular drawtube having a diameter of 25 mm, as have, e. g. all astronomical telescopes from Jena and many of other origins. When photographic work has to be interrupted, in order to view the heavenly bodies directly, the camera can be removed from the telescope by loosening the clamp-screw on the quick-change fitting in one single movement. Likewise can the EXAKTA quickly be brought back into action, since the upper part of the telescope adapter remains attached to the telescope.

Order number: Telescope adapter 199

Additional accessories

for IHAGEE cameras can only be listed briefly in order to complete this survey of the full range of equipment. For further information consult the publications dealing with the various cameras.

Ever-Ready Leather Case

Indispensable for every camera.

Lens Hood

The only effective means of protecting the lens against flare. Latest rectangular design; with screw-in thread.

Giant Release Button

Enlarges the contact area of the camera release button: invaluable for taking pictures with cold or gloved hands.

Polarizing Filter

Special screw-in filter for eliminating distracting reflections from shiny, non-metallic surfaces such as glass, water, varnish, etc.

Accessory shoe

This is attached to the eyepiece of the Penta Prism or Penta-Prism Viewfinder and permits the attachment of accessories e. g. flash units, exposure meters, etc. to the camera.

Finder Hood

Interchangeable focusing equipment for the EXAKTA and EXA I a.

Penta Prism

Available for the EXAKTA and EXA I a: the focusing system which provides a constantly upright and laterally-correct reflex image.

Eyepiece

Strongly recommended for excluding stray-light from the Penta Prism and the Prism Viewfinder of the EXA 500. Also designed for accommodating vision-correction lenses.

Fresnel lens

Provides a uniformly brilliant reflex image and contains a microprism field providing an additional means of focusing. Can be used with the Finder Hood, Penta Prism, and Lens Magnifier (als available as an integral feature of the EXA 500, on request).

Focusing screen with frame lines

Simplifies the selection of long-focus lenses by indicating the image area covered by 135, 180, and 300 mm lenses. Can be employed in the Finder Hood, Penta Prism, and Lens Magnifier.



Wide-angle lenses

For exposures with large angle of acceptance. Available for focal lengths of 20 mm to 35 mm (93° to 62° angle of acceptance) and also with fully automatic spring diaphragm.

Special ultra-high-speed lens

A truly remarkable "Night Lens" with an aperture of f 1.5 and focal length of 75 mm.

Special long-focus lenses

Bring distant objects closer, like a telescope. Available with focal lengths ranging from 75 up to 1000 mm (angular field 32 to 2.5°). With fully-automatic spring or pressure diaphragms up to f = 300 mm.



Special literature

The following TEXT books deal exclusively with IHAGEE equipment:

(In German)

"EXAKTA Kleinbild-Fotografie" by Werner Wurst

(also available in English as "EXAKTA MANUAL", published by Fountain Press, London)

"Foto-Exkursionen mit der EXA" by Werner Wurst

(also available in English as "The EXA Book" published by Focal Press, London)

both available from VEB FOTOKINO-VERLAG, Leipzig

Original

**EXA
EXAKTA**

Dresden



(In English)

"35 mm EXAKTA Handbook" by K. L. Allinson A. R. P. S. (Fountain Press, London)

"35 mm Photography with an EXAKTA" by K. L. Allinson, A. R. P. S. (Fountain Press, London)

"EXAKTA Photography" by Jacob Deschin

(Camera Craft Publishing Co., San Francisco 5, California)

DURKIN PHOTOGRAPHIC
Heritage Square

HERITAGE SQUARE

1700 POST ROAD

FAIRFIELD, CONN. 06430

Tel: (203) 259-8555

**IHAGEE KAMERAWERK AG in Verwaltung
8016 DRESDEN**

The illustrations in this manual may differ slightly in minor details to the actual appearance of the cameras and accessories.

Form 712c/20/6711 Made in Germany

III/18/97 Ag 22/084/67 **E**