

# MONITAL

5:1 ZOOM LENS  
17-85 mm f/2.  
MANUAL LEVER  
CONTROL

## 'THE' LENS FOR 16mm MOTION PICTURE CAMERAS

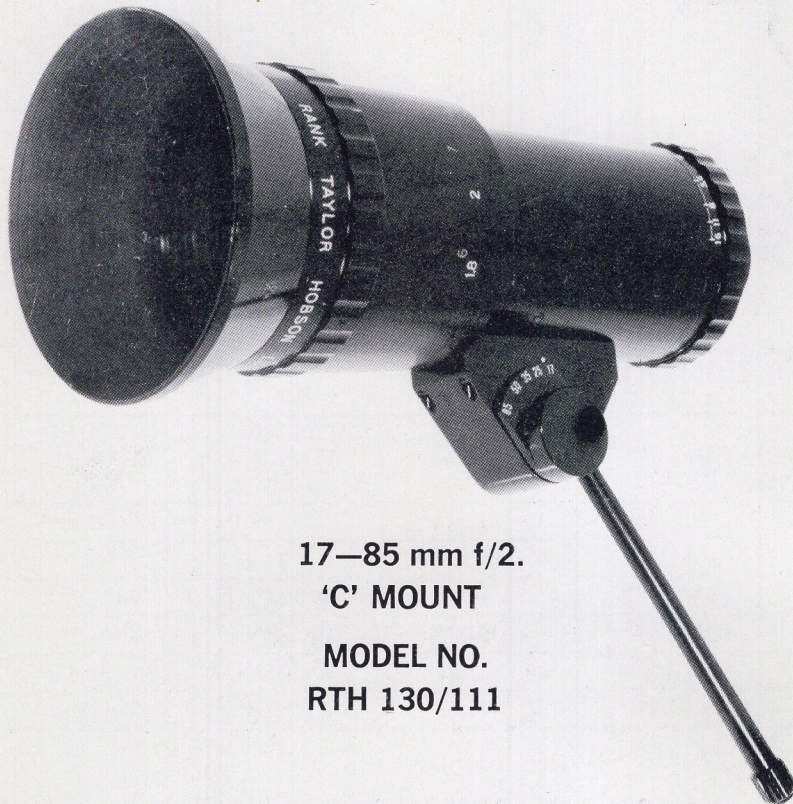

17-85 mm f/2.  
'C' MOUNT  
MODEL NO.  
RTH 130/111



17-85 mm f/2  
'C' MOUNT  
WITH ST'D OFFSET  
VIEWFINDER  
MODEL NO.  
RTH 130/112

The Monital lens is a well corrected zoom lens with an optical performance comparable to that of a good fixed focal length lens. The cameraman will find that it will make the most of today's modern fine emulsion films in black and white or color. This lens is rigidly constructed of high strength light weight aluminum alloy with a steel hard anodized finish. White scale marks engraved on the barrel make for exceptionally clear and easy reading of zoom, iris, and focus positions. The internal mechanism consists of a piston-like movement of the two elements that alter the focal length and ride in the lens barrel on low friction teflon slipper pads to virtually eliminate wear.

Monital lenses are available with or without the Telemetric view-finder. It affords full reflex facilities and also a precise indication of focus. This is extremely useful when the camera is not fitted with an internal reflex view-finder.

Three attachments are available for this lens. Two close-up attachments ( $\frac{1}{2}$  diopter and 1 diopter) and a macro zoom attachment.

For specifications see reverse side.

UNITED STATES DISTRIBUTORS FOR RANK TAYLOR HOBSON

LOCALLY DISTRIBUTED BY:

5:1 ZOOM LENS 17-85 mm f/2.0

**albion**  **rank taylor hobson**

260 NORTH ROUTE 303 WEST NYACK, NEW YORK 10994 - 914-358-4450 TELEX 137-442



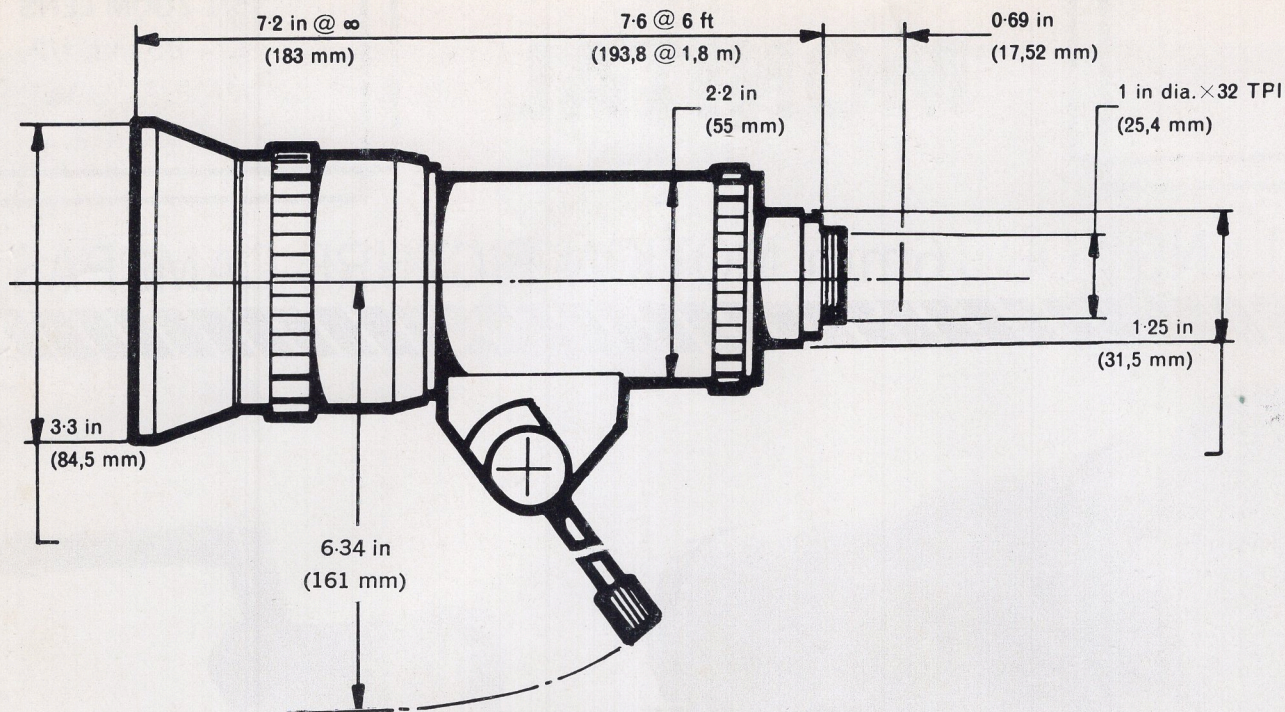

## OPTICAL SPECIFICATIONS

	BASIC OPTICS	MACRO ZOOM	CLOSE-UP ATTACH X 1	CLOSE-UP ATTACH X 1/2
RANGE OF FOCAL LENGTHS	17-85 mm	17-85 mm	17-85 mm	17-85 mm
MAXIMUM RELATIVE APERTURE	f/2	f/2	f/2	f/2
APPROXIMATE ANGULAR FIELD OF VIEW	HORIZONTAL	34°-7°	34°-7°	34°-7°
	DIAGONAL	40°-8°	40°-8°	40°-8°
OBJECT DIM. AT MIN. DISTANCE AND MAX. FOCAL LENGTH	6.8 x 4.8 in	.48 x .35 in	2.4 x 1.8 in	3.6 x 2.4 in
FOCUSING	∞-6 ft	4 in	43-30 in	60-41 in

## CAMERAS THAT CAN USE THE MONITAL ZOOM LENS

This lens can be used on virtually any camera with the standard C Mount and can be supplied with suitable mounts for some special cameras.

AK 16 . . . studio special

Arriflex 16 . . . special

Auricon Cinevoice . . . standard

Auricon 600 . . . standard with horizontal view-finder

Auricon 1200 . . . standard with horizontal view-finder (with some camera modification)

Beaulieu R 16 . . . standard without view-finder

Bell & Howell Filmo 70 . . . standard

Bell & Howell magazine 16 . . . standard

Bolex . . . standard

Cameflex . . . special

Camex . . . special

Debrie . . . studio

Eclair . . . special

Kodak-Special 1 and 11 . . . special  
Mitchell 16 . . . horizontal view-finder (with some camera modification)

Mitchell 16 RX . . . studio

Paillard H 16 Std and RX, M 16 . . . standard

Pathé Webó M 16 and Super 16 . . . standard without view-finder

Pathé Webó . . . standard without viewfinder

## MODEL NUMBER AND PRICE OF MONITAL 5:1 POCKET ZOOM LENS AND ACCESSORIES

FOCAL LENGTH	APERTURE	DESCRIPTION	MOUNT	MODEL NO.	LIST PRICE
17-85 mm	f/2	without view-finder	C Mount	RTH 130/111	\$298.00
17-85 mm	f/2	with view-finder	C Mount	RTH 130/112	\$529.00
17-85 mm	f/2	with Auricon view-finder	C Mount	RTH 130/153	\$635.00
17-85 mm	f/2	without view-finder	Arriflex	RTH 130/154	\$356.00
Macro Zoom				RTH 130/60	\$ 83.00
Close up Attachment	X 1/2			RTH 130/61	\$ 30.00
Close up Attachment	X 1			RTH 130/62	\$ 30.00