

Rollei P37 autofocus

autofocus 'Theater in the Round' 2 x 2 Slide Projector

By adapting the successful P35E technology, combining it with a circular magazine, truly contemporary and handsome styling the new 'P37 autofocus' model, 'the theater in the round', becomes the ideal unit for private or professional projection of 24 x 36 mm transparencies. The circular magazine for eighty 2 x 2 slides allows uninterrupted and automatic slide projection.

AUTOMATIC FOCUSING

Full automation means optimum operational convenience by high performance precision engineering. This is the basis on which the fully automatic 'P37 autofocus' slide projector has been designed. Its most outstanding technical feature is the special autofocus system which *automatically* and *instantly* focuses slides in 2 x 2 inch mounts for precise sharpness, even when mixing glass-bound, plastic-mounted or card-framed slides.

CONTINUOUS AUTOMATIC SLIDE CHANGING

Built-in timer: automatically controls the slide change at pre-selectable intervals (between 3 and 30 seconds).

Forward and reverse slide transport with remote control. Slide changing forward and reverse by press button key on projector. Slide changing also possible by tape control with other manufacturers' accessory units; also manual operation if required.

FEATURES AND TECHNICAL DATA

- Extra fast autofocusing of slides
- Auto push button and remote slide changing
- Forward, reverse and continuous operation
- Timed slide changing—3 to 30 seconds
- V-groove slide arm for slide protection
- Unique low profile contemporary design; the 'Rollei look'
- 150 Watt 24 Volt tungsten halogen lamp (FCS)
- * Variable voltage selector: 110/120/130/220/230/240 volts, 50-60 Hz
- Aspheric condenser system for brilliant even illumination
- Cool operation with silent-running enclosed radial fan
- No spilled light—easy access lamp replacement
- Silver finish with tinted acrylic dust cover
- 80 capacity circular magazine with numbers
- Individual slides accessible at all times
- Standard lens: Rollei Projar 85mm/f2.8
- Optional accessory lenses available—

see page 40

ROLLEI P37 autofocus 2 x 2 SLIDE PROJECTOR w/85mm (std.) lens, AC power cord, remote control cord, FCS lamp, case and one circular magazine **Cat. No. 685 060** (09900)

ROLLEI P37 autofocus 2 x 2 SLIDE PROJECTOR as above but with Vario Projar 70-120mm lens **Cat. No. 700 709** (09928)

ROLLEI P37 autofocus 2 x 2 SLIDE PROJECTOR as above, LESS lens **Cat. No. 685 100** (05333)

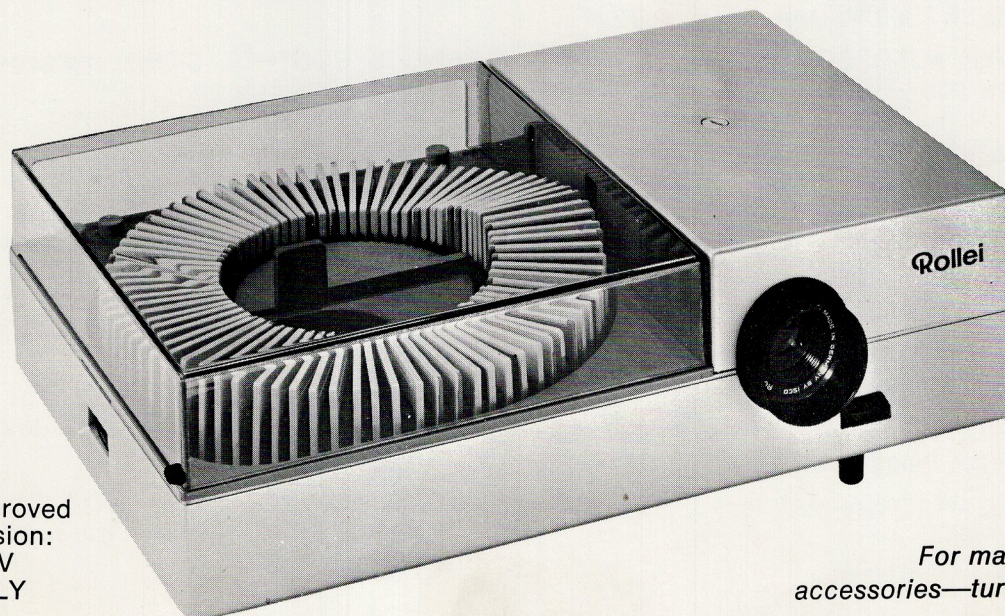

*
UL
approved
version:
120V
ONLY

For magazines and
accessories—turn page →

Accessories For Rollei 2 x 2 Slide Projectors

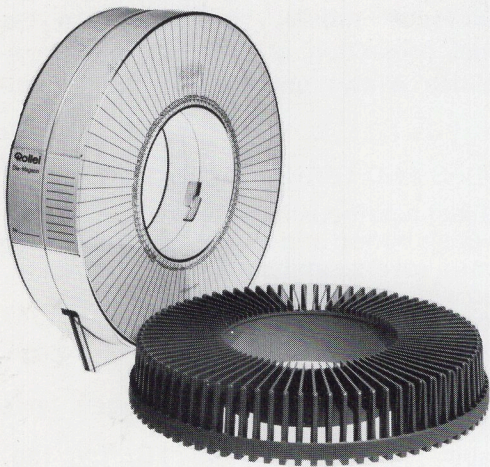

For P37 autofocus only

	Cat. No.		Cat. No.
CIRCULAR SLIDE MAGAZINE for 80 slides, includes transparent case for vertical filing	680 200 <i>(09919)</i>	AC CORD, replacement for P37 autofocus	630 350 <i>(15103)</i>
CASE FOR P37 autofocus Projector, replacement	970 690 <i>(22284)</i>	REMOTE CONTROL CORD, replacement for P37 autofocus	680 240 <i>(22248)</i>
24V-150W QUARTZ HALOGEN LAMP, (FCS)	974 440 <i>(05041)</i>		

For P35 autofocus and P35A

2 MAGAZINES (slide trays) 55-50 in case (holds 50 2 x 2 slides)	974 400 <i>(13301)</i>	24V 150W QUARTZ HALOGEN LAMP (FCS)	974 440 <i>(05041)</i>
2 MAGAZINES (slide trays) 55-36 in case (holds 36 2 x 2 slides)	974 410 <i>(13310)</i>	AC CORD, replacement for P35 Auto	630 350 <i>(15103)</i>
CASE FOR P35 AUTOFOCUS Projector (also fits P35/P35A)	970 520 <i>(15529)</i>	REMOTE CONTROL CORD, replacement for P35 Auto	600 510 <i>(17057)</i>

For P37 and P35 Series

ROLLEI PROJAR 50mm f/2.8 lens (for 110 format and up to 18 x 24mm only)	979 380 <i>(15839)</i>	BOX OF SLIDE MOUNTS with regular glass for 24 x 36mm transparencies	974 280 <i>(13338)</i>
ROLLEI PROJAR 85mm f/2.8 standard lens, replacement	979 390 <i>(15848)</i>	BOX OF 20 SLIDE MOUNTS with Anti-Newton ring glass, for 24 x 36mm transparencies	974 270 <i>(13347)</i>
ROLLEI S PROJAR 90mm f/2.5 lens of exceptional correction	979 500 <i>(15866)</i>	GLASS, REPLACEMENT REGULAR, for 24 x 36mm transparencies, Box of 50	974 300 <i>(13356)</i>
ROLLEI VARIO-PROJAR, 70-to-120mm variable focal length lens	979 410 <i>(15857)</i>	GLASS, REPLACEMENT ANTI-NEWTON RING for 24 x 36mm transparencies, Box of 50	974 260 <i>(13365)</i>
ROLLEI PROJAR 150mm f/3.5 lens	979 770 <i>(07515)</i>		

Rollei P66 autofocus

world's only 2¼ x 2¼ autofocus slide projector

Small fully automatic model for 2¼ x 2¼ slides; the projector for medium format slides with automatic focusing, built-in timer and tungsten halogen lamp. The perfect projector for amateurs and professionals involved with the popular 2¼ x 2¼" square format.

Variable voltage selector: 110/120/130/220/230/240 volts; 50-60 Hz.

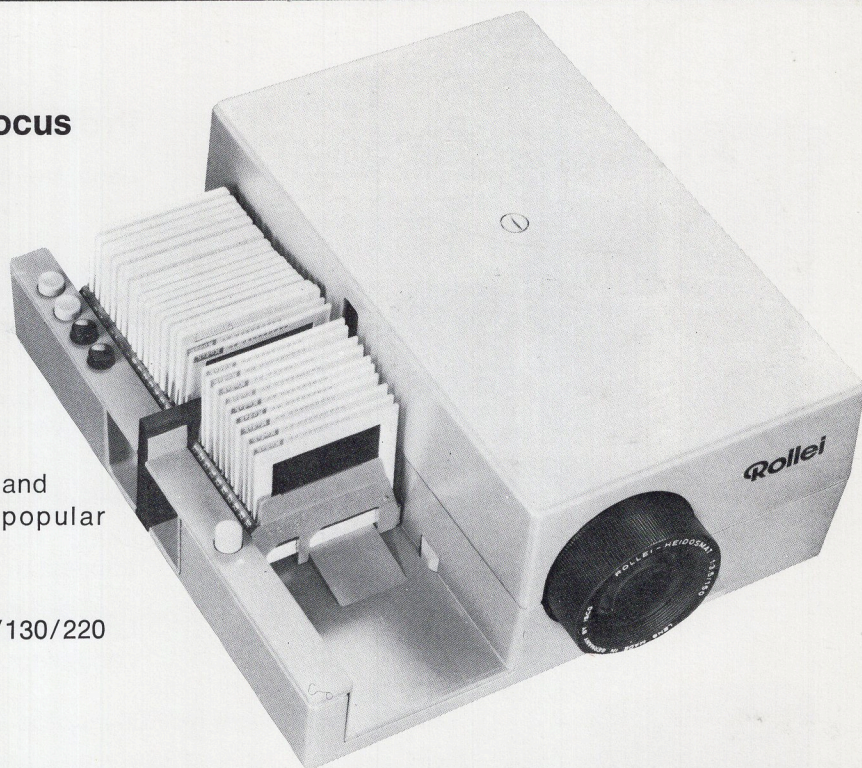

ROLLEI P66 autofocus PROJECTOR, Supplied w/AC cord, remote control cord, FCS lamp; less lens, less case

LENS, Heidosmat 150mm/3.5

CASE, Carrying

Cat. No. 620 060 (22594)

Cat. No. 979 780 (05324)

Cat. No. 970 750 (05546)

Finally, the Rollei P66 autofocus—a small but fully automated projector for large slides 2¼ x 2¼" with the resulting superior brilliance and color saturation gained from a picture area substantially 4X larger than 35mm slides.

Autofocus projection—image focusing of the first slide is done by two push-buttons on the projector or by means of rocker-switch on remote control—thereafter, all slides come into sharp focus on the screen instantly and automatically.

Selectively timed projection—built-in automatic timer provides for automatically timed projection intervals from 3 to 30 seconds.

Slide changing by remote control—remote control cord gives single button control for forward and reverse slide changing. (8¼ feet length may be extended 100 feet by means of 33 feet extension cables.) Short interval button pressure for forward—longer for reverse. (Push-button on projector also provides forward and reverse action and single slides may be placed in V-channel carrier for individual projection.)

Easy access to all slides—uncovered 30-capacity tray provides instant access to all slides even when tray is inserted into projection track.

Optical system—large condenser system, including aspheric, gives brilliant image illumination from edge to edge with high efficiency 24V/150W

tungsten halogen lamp (FCS). Heat filter and radial fan cooling protect slides ... and there's no light spill from top of projector.

Projection lenses—standard lens is Heidosmat 150mm/f3.5 Accessory lenses include special highly corrected S-Heidosmat 150mm/f2.8; Heidosmat 180mm/f3.5; and the Vario-Heidosmat 110-160mm/f3.5 with continuously variable focal length. The P66 autofocus, easily portable, is not larger than many 35mm slide projectors, yet offers amateurs and professionals the chance to conveniently view 2¼ slides, (whether mounted in cardboard, glass, plastic or metal mounts) as returned by most laboratories. Here's the ideal adjunct for advertising agencies, lecturers, schools and editors to preview material for editorial purposes. Here's the extra visual impact of 2¼ x 2¼ projection for amateurs and professionals.

Dimensions: 10⅞ x 4⅞ x 11⅝" (27.6 x 12.4 x 29.5cm)

Weight: 14 lbs. (6.4kg)

Six-pole socket makes sound synchronization adaptation possible with slide control unit for sound show presentations from tapes or cassettes. All solid aluminum pressure-cast housing in modern silver-metallic finish.

P66 autofocus has built-in TV and radio interference suppression.

Overleaf for accessories



Accessories for Rollei P66 autofocus Projector



Projection Lenses for P66 autofocus

Lens, Heidosmat 150mm/3.5 (standard lens)
Cat. No. 979 780 (05324)

Lens, S-Heidosmat 150mm/2.8 special lens of standard focal length—5-element construction; superior optical correction. **Cat. No. 979 510** (13550)

Lens, Vario-Heidosmat 110-160mm/3.5, continuously variable focal length. **Cat. No. 979 035** (07533)

Lens, Heidosmat 180mm/3.5. **Cat. No. 610 225** (07755)

Lens, Heidosmat 250mm/3.0 w/supplementary condensor. **Cat. No. 610 235** (07977)

Lens, Heidosmat 400mm/4.0 w/supplementary condensor. **Cat. No. 979 910** (08192)



CASE, replacement for P66 autofocus projector. **Cat. No. 970 750** (05546)

CORD, Remote Control, replacement. **Cat. No. 630 310** (06424)

CORD, Extension f/Remote Control, 10m (33') length. **Cat. No. 610 540** (13587)

CORD, AC, replacement. **Cat. No. 610 610** (15103)

CORD, Tape Recorder Coupling. **Cat. No. 610 640** (13596)

LAMP, replacement 24V 150W (FCS). **Cat. No. 974 440** (05041)

SLIDE TRAY—77-30—holds 30 transparencies $2\frac{1}{4} \times 2\frac{1}{4}$ (6 x 6cm) in standard mounts $2\frac{3}{4} \times 2\frac{3}{4}$ (7 x 7cm).

Cat. No. 974 030 (13648)

SLIDE MOUNTS—

Although the Rollei P66 autofocus projector accepts slides in card board mounts of suitable rigidity, the following glass and plastic mounts are offered for those desiring greater slide protection:

Box of 12 Rollei Slide Mounts with regular glass for transparencies $2\frac{1}{4} \times 2\frac{1}{4}$. **Cat. No. 974 040** (13657)

Box of 12 Rollei Slide Mounts with anti-Newton ring glass for transparencies $2\frac{1}{4} \times 2\frac{1}{4}$. **Cat. No. 974 240** (13666)

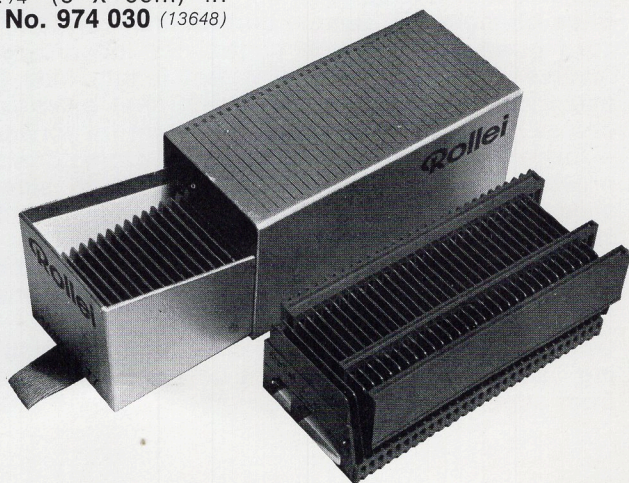

Brilliant, Versatile, Cool, Quiet Quality

- Versatile and universal: Projects slides from 12x17mm in 2x2 mounts to 2 1/4 x 2 1/4 (6x6cm) in 2 3/4 x 2 3/4" mounts.
- Brilliant lighting system—with aspheric condenser and efficient fan cooling system. Uses 300W(CWD) lamp (or 500W(DAK) lamp with secondary heat filter). External setting screw for lamp recentering.
- Fully automatic slide changing with press button keys or remote control switch. Automatic forward and reverse.
- Remote control motor drive focusing.
- Dual line voltage range: 110-117V and 120-127V 60 cycle AC.
- Two slide magazine tracks—one for 2 x 2" frames; one for 2 3/4 x 2 3/4" frames—two slide stages to utilize full lamp output.
- Choice of 7 lenses—for various format coverage; solves home, exhibition hall and auditorium questions of space and projection distances. (see next page)
- Tape recorder control outlet—to link tape recorder with the Universal one needs only an impulse generator and a supplementary lead.
- Instant access to optical—lamp system.
- Uses standard Rollei, Leica, Zeiss, Agfa magazines.

ROLLEI UNIVERSAL PROJECTOR, UL approved; including AC cord, remote control cable, one 77-30 magazine, one 55-36 magazine: with 300W lamp; less lens, less case.
Cat. No. 700 710 (14775)

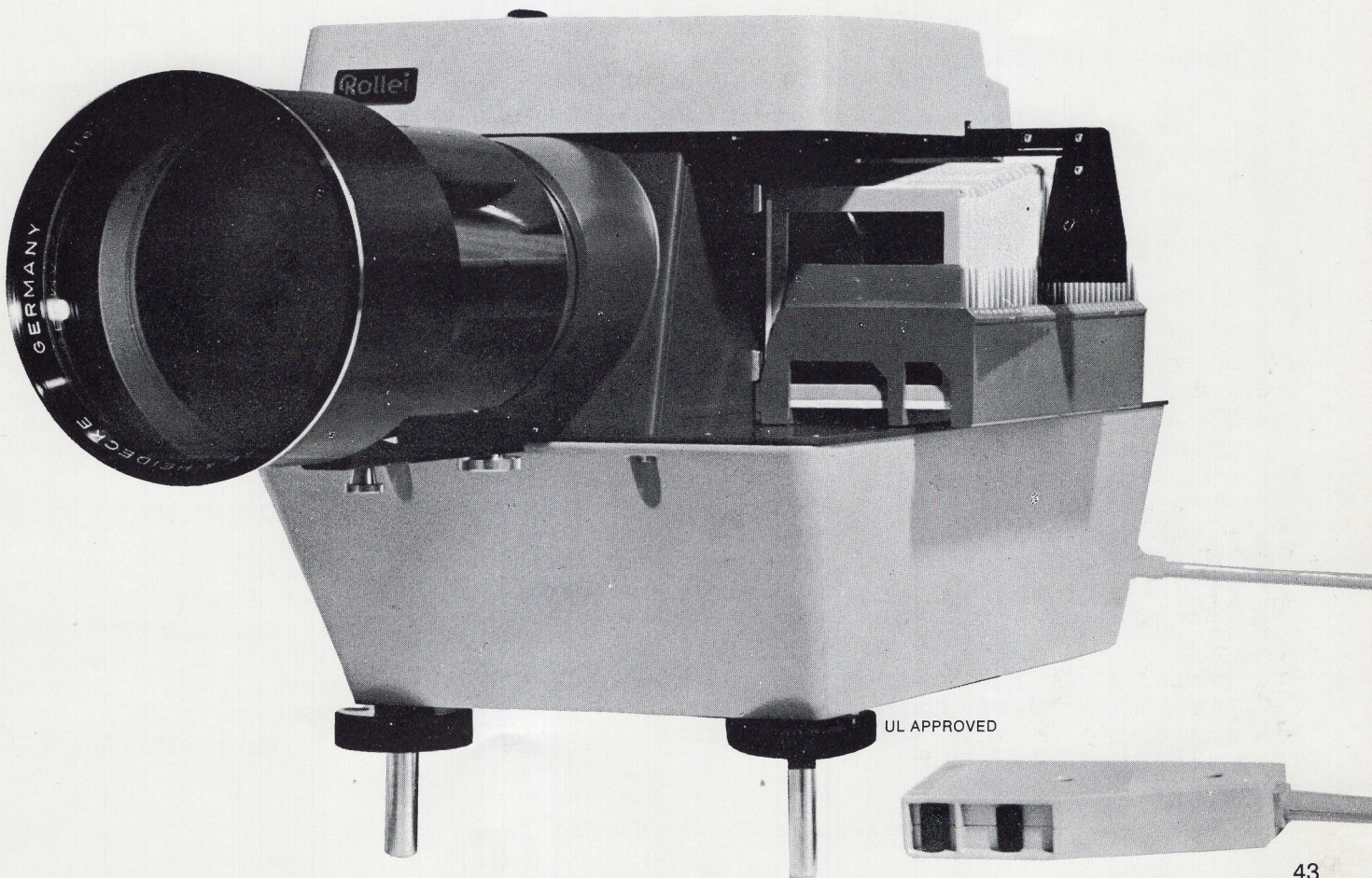

Accessories For Rollei P11 Projector



Lenses for P11 Universal Projector

45mm f/2.8 (1 $\frac{1}{2}$ ") Heidosmat Lens (for 12 x 17mm and 110 Format ONLY) **Cat. No. 610 240** (13480)

SPECIAL CONDENSOR and Heat Filter (for use with 45mm projection lens ONLY)
Cat. No. 610 580 (13639)

110mm f/2.8 (4 $\frac{1}{2}$ ") Heidosmat Lens (for 35mm, 2 x 2 slides) **Cat. No. 610 200** (13499)

150mm f/2.8 (6") Heidosmat Lens (Standard lens) **Cat. No. 610 210** (13505)

180mm f/3.5 (7 $\frac{1}{8}$ ") Heidosmat Lens, w/support **Cat. No. 610 220** (13514)

250mm f/3.0 (9 $\frac{7}{8}$ ") Heidosmat Lens, w/support **Cat. No. 610 230** (13523)

400mm f/4.0 (16") Heidosmat Lens, w/support **Cat. No. 979 040** (13532)

SPECIAL LENSES

110-160mm f/3.5 (4 $\frac{1}{2}$ "-6 $\frac{1}{4}$ ") Vario Heidosmat. Without changing the projector position one can adjust the image size to match the size of the screen. Also brings superslides and large 2 $\frac{1}{4}$ x 2 $\frac{1}{4}$ inch transparencies to the same projected image size by simply turning a ring at the front of the lens. incl. support. **Cat. No. 979 030** (13541)

150mm f/2.8 (6") S-Heidosmat Lens (Special projection lens of superior correction for critical applications). **Cat. No. 979 510** (13550)

Other Accessories—P11 Projector

CASE, FOLDING for P11 Projector, cords and lens. **Cat. No. 972 280** (13471)

TRAY No. 77-30—holds 30 mtd. 2 $\frac{1}{4}$ x 2 $\frac{1}{4}$ slides. **Cat. No. 974 030** (13648)

TWO TRAYS No. 55-50 in plastic box (each tray holds 50 mtd. 2 x 2 slides). **Cat. No. 974 400** (13301)

TWO TRAYS No. 55-36 in plastic box (each tray holds 36 mtd. 2 x 2 slides). **Cat. No. 974 410** (13310)

CORD, AC repl. **Cat. No. 610 600** (14942)

CORD, Remote Control, repl. **Cat. No. 610 500** (13578)

CABLE, Extension for Remote Control. 33' length may be coupled to 100'. **Cat. No. 610 540** (13587)

*CORD for COUPLING TAPE/CASSETTE RECORDERS; couples German standard recorder receptacle and projector, also connects to Remote Control Cord for focus control. **Cat. No. 610 640** (13596)

* This Y cord can be modified for any tape or cassette recorder having a built-in synchronizer/impulse generator or an accessory external synchronizer. Contact manufacturer of recorder or synchronizer to determine correct fittings to mate connections. Adaptation—to be performed by your local electronics shop.

‡EXTRA HEAT FILTER must be used with 500W (DAK) lamp; also recommended for use with 400W. **Cat. No. 610 570** (13620)

LAMP 300W (CWD). **Cat. No. 700 717** (05014)

‡LAMP 500W (DAK) use with extra heat filter. **Cat. No. 700 718** (05032)

LAMP 400W (CYK) 200 HR. **Cat. No. 700 719** (05023)

For Slide Mounts—See Page 45

Rollei Slide Mounts

Slide Mounts for 2¼ x 2¼ Transparencies

Easily opened and closed plastic frames with glass for 2¼ x 2¼" (6 x 6cm) transparencies; O.D. Dimensions of mounts 2¾ x 2¾" (7 x 7cm).

BOX of 12 ROLLEI SLIDE MOUNTS with regular glass for 2¼ x 2¼ transparencies.

Cat. No. 974 040 (13657)

BOX of 12 ROLLEI SLIDE MOUNTS with Anti-Newton ring glass for 2¼ x 2¼ transparencies.

Cat. No. 974 240 (13666)

REPLACEMENT GLASS, 2¼ x 2¼ regular Box of 50.

Cat. No. 974 050 (13675)

REPLACEMENT GLASS, 2¼ x 2¼, A.N. glass Box of 50.

Cat. No. 974 250 (13684)

Slide Mounts for 35mm (24 x 36mm) Transparencies

Reuseable 2 x 2" plastic mounts with glass; 23.3 x 35.6mm aperture dimension.

BOX of 20 SLIDE MOUNTS with regular glass for 24 x 36mm transparencies.

Cat. No. 974 280 (13338)

BOX of 20 SLIDE MOUNTS with Anti-Newton ring glass for 24 x 36mm transparencies.

Cat. No. 974 270 (13347)

REPLACEMENT GLASS, REGULAR for 24 x 36 transparencies, Box of 50.

Cat. No. 974 300 (13356)

REPLACEMENT GLASS, A.N. for 24 x 36 transparencies, Box of 50.

Cat. No. 974 260 (13365)

Slide Mounts for Super-slide Transparencies

Reuseable plastic mounts of 2 x 2" (5 x 5cm) outside dimensions having 37.3 x 37.3mm aperture dimension for square super-slide format.

BOX of 20 SLIDE MOUNTS for super-slide with Regular glass.

Cat. No. 974 290 (13374)

BOX of 20 SLIDE MOUNTS for super-slide with Anti-Newton ring glass.

Cat. No. 974 330 (13383)

REPLACEMENT GLASS, REGULAR for super-slides, Box of 50.

Cat. No. 974 310 (13392)

REPLACEMENT GLASS, A.N. for super-slides, Box of 50.

Cat. No. 974 320 (13408)

Slide Mounts for Super 16 Transparencies

Reuseable plastic mounts of 2 x 2" (5 x 5cm) outside dimensions for Super 16 transparencies with Rollei 16(S) camera; 11 x 16mm aperture dimension.

BOX of 20 SLIDE MOUNTS for Super 16 with Regular glass.

Cat. No. 974 370 (10214)

BOX of 20 SLIDE MOUNTS for Super 16 with Anti-Newton ring glass.

Cat. No. 974 380 (10223)

REPLACEMENT GLASS, REGULAR f/Super 16 Pkg. 40.

Cat. No. 974 460 (10232)

