

H A S S E L B L A D

503cx
500C/M

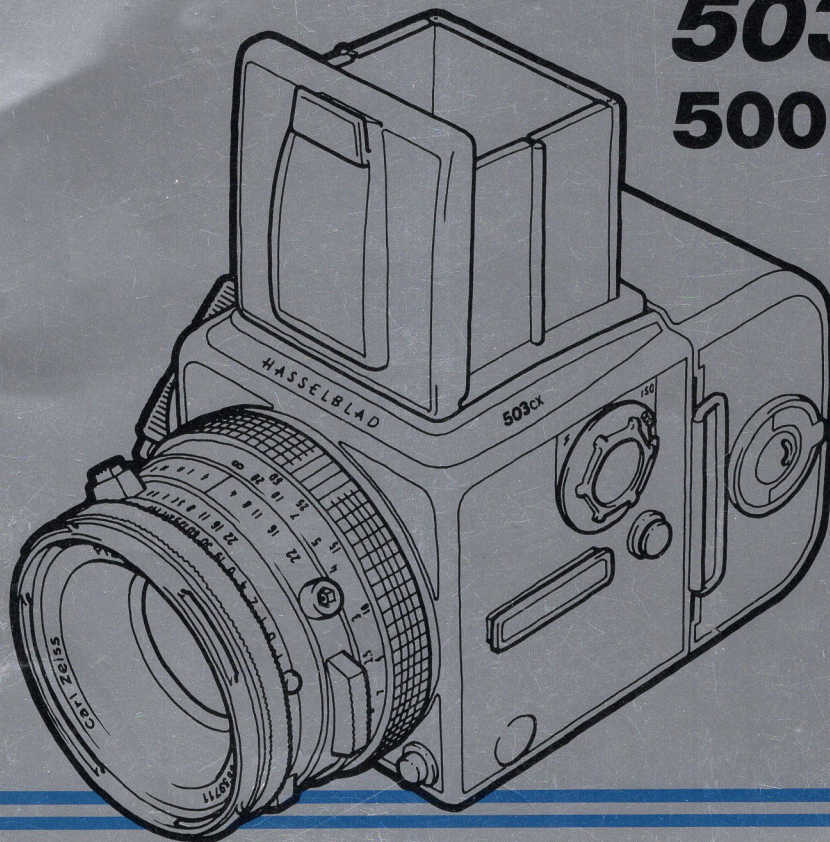

INSTRUCTION MANUAL

Hasselblad 503cx & 500C/M Manual

Page		Page	
3	Introduction	17	Checking Depth of Field
		17	Flash Synchronization
6	Basic Operation	18	Magazine Operation
6	Front Protective Cover	18	Loading the Magazine
6	Rear Protective Cover	20	Load Status and Film Type Indicators
6	Attaching the Lens	20	Removing the Film
7	Removing the Lens	20	Film Plane Index
8	Attaching the Magazine	21	Viewfinder System
8	Removing the Magazine	21	Changing the Viewfinder
9	Indicators	21	Changing the Magnifier
10	Focusing Hood and Magnifier	22	Changing the Focusing Screen
10	Winding Crank	23	PME3/PME Viewfinder Adjustments
11	Strap Lugs		
11	Left Hand Grip	25	503cx only
11	Focus and Release	25	Automatic Flash Control
		26	Flash Adapters 390/590
12	Operating Details	26	Film Speed Setting
12	Exposure	27	Viewfinder Signal
12	Time Lock		
13	Pre-release and Cable Release	28	Accessories
13	Double Exposure	28	Accessory Mounts
14	Lens and Shutter Functions	29	Accessory Chart
14	Shutter Speeds		
14	Aperture	30	Technical Specification 503cx
15	Exposure Values	31	Technical Specification 500C/M
15	Interlocked Shutter Speed/Aperture	32	Camera Body Dimensions
16	Focusing and Depth of Field	33	Troubleshooting
16	Infrared Photography	34	Camera Care, Service and Guarantee

Copyright © 1988, Victor Hasselblad AB.

All rights reserved. No part of this material may be reproduced, stored in a retrieval system, or transmitted, in any form or by any means, electronic, mechanical, photocopy, recording, or otherwise, without the prior written permission of the company.

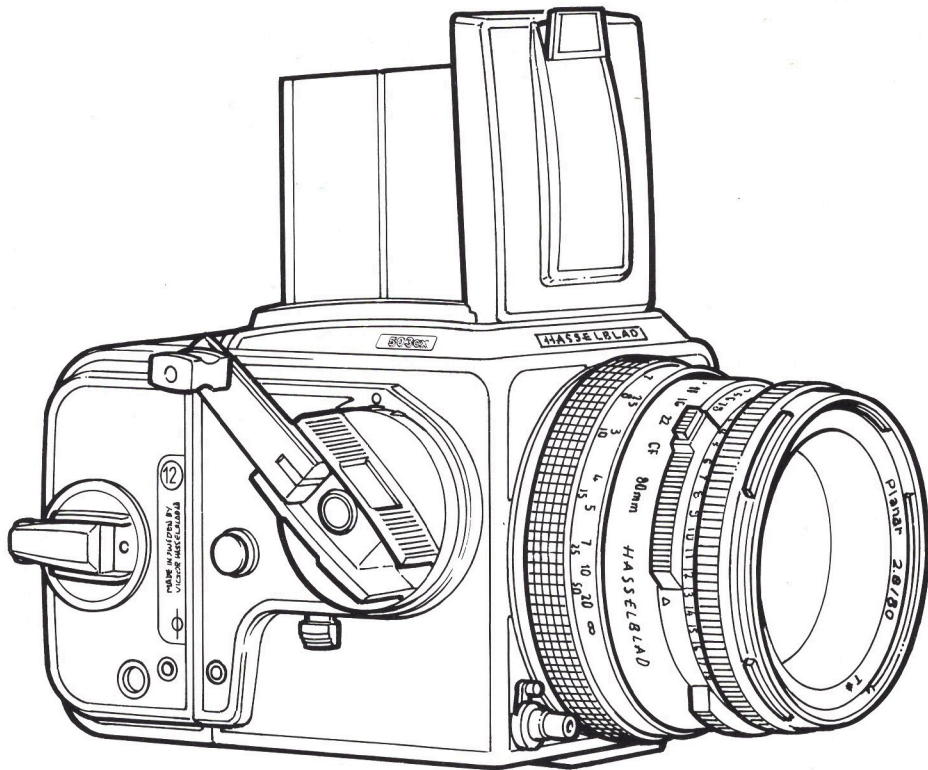

Guarantee

Provided that you bought your camera from an authorised Hasselblad outlet, it is covered by an international guarantee for one year. Further details can be found on page 34.

Service and Maintenance

Whilst Hasselblad equipment is extremely reliable and durable, cameras and lenses that are in constant intensive use in a professional environment should be maintained and serviced by an authorised Hasselblad service centre at regular intervals. Further information on service and maintenance can be found on page 34.

Introduction to the Hasselblad Camera System

As a Hasselblad owner, you have in your possession a camera of exceptional quality, the product of an internationally renowned tradition of excellence in the world of photography. Victor Hasselblad, the father of the cameras which bear his name, was himself an accomplished photographer. It was to satisfy his own exacting standards and diverse requirements that he first envisioned the Hasselblad system: a medium format single lens reflex camera with interchangeable lenses and film magazines. A photographer first and businessman second, Victor Hasselblad would never sacrifice quality for ease of production. To this day, Hasselblad cameras are painstakingly crafted with this principle in mind.

The Hasselblad system has been taken to the ends of the earth and beyond – into space, to earn its reputation for reliability and absolute fidelity. A range of accessories affords limitless flexibility and the potential for paramount photography in any application. The realisation of this potential is of course dependant upon the skill, care and judgement of the photographer.

The Hasselblad 503cx and 500C/M are medium format single lens reflex cameras featuring lens, magazine, viewfinder and focusing screen interchangeability. The 503cx is an upgraded version of the 500C/M with through the lens 'OTF' (Off

The Film) flash metering and a number of additional refinements.

This instruction manual describes in detail how to operate both cameras. Where the operation of the cameras is the same, a single set of instructions common to both models is presented. The illustrations accompanying the common instructions show the 503cx, as this is the most recent model, but apply equally to the 500C/M. Where there are operating differences between the 503cx and the 500C/M, these are documented separately.

Lenses

Since the early 1950's Hasselblad lenses have been manufactured by Carl Zeiss in West Germany. The Hasselblad 503cx and 500C/M use CF and C lenses made by Carl Zeiss.

With the exception of "F" type lenses, all Hasselblad lenses manufactured since 1957 can be used with the 503cx and 500C/M. F-lenses can only be used with the Hasselblad 2000 series cameras.

Use this manual to learn how to operate your camera. The knowledge gained from reading it will give you access to the Hasselblad potential. Exploiting the potential is left to your imagination!

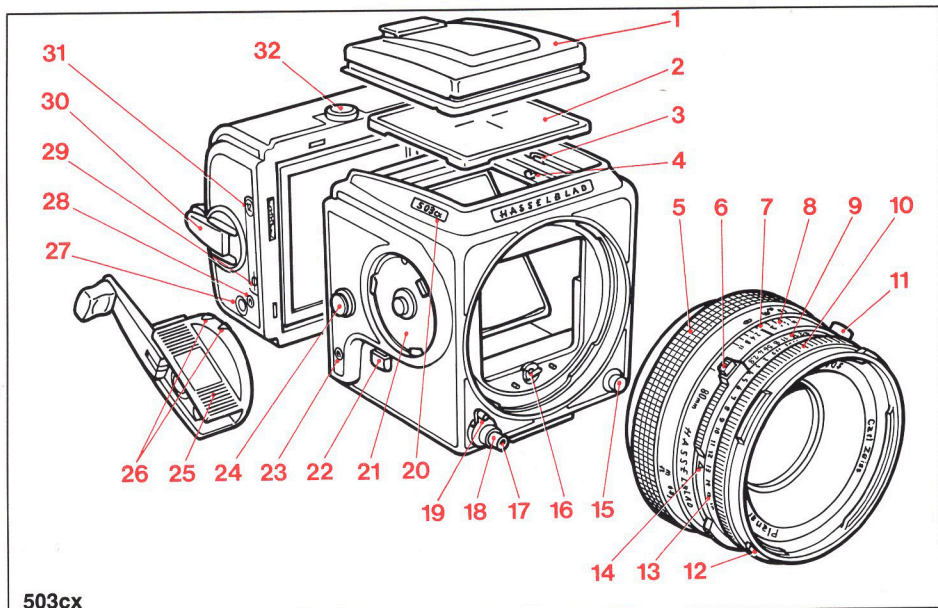

503cx and 500C/M Components

- | | | |
|---|---|-------------------------------|
| 1. Focusing hood | 10. Shutter speed selector ring | 21. Winding crank bayonet |
| 2. Focusing screen
503cx Acute-Matte† screen
500C/M ground-glass screen | 11. PC flash terminal | 22. Pre-release button |
| 3. Screen retaining clip | 12. External and internal lens
accessory mount | 23. Camera status indicator |
| 4. Flash function indicator* | 13. Exposure value scale | 24. Strap lug |
| 5. Focusing ring and scale | 14. Exposure value index | 25. Winding crank |
| 6. Shutter speed and aperture
interlock button | 15. Lens lock release button | 26. Winding crank index |
| 7. Central lens index | 16. Drive shaft | 27. Frame counter |
| 8. Depth-of-field scale | 17. Threaded cable release socket | 28. Magazine status indicator |
| 9. Aperture ring and scale | 18. Shutter release button | 29. Film plane index |
| | 19. Time exposure catch | 30. Film winding crank |
| | 20. Name plate* | 31. Magazine designation |
| | | 32. Magazine catch |

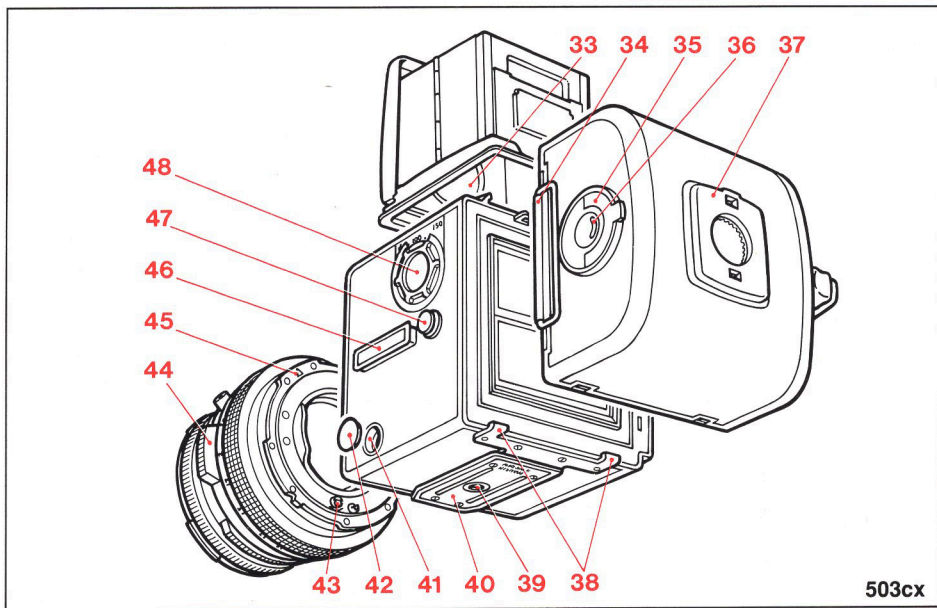

- 33. Focusing hood magnifier
- 34. Magazine slide
- 35. Film holder key
- 36. Film consumption indicator
- 37. Film speed and type indicator
- 38. Magazine support hooks
- 39. Tripod socket 1/4 in. thread

- 40. Quick coupling plate
- 41. 6 pin OTF metering output*
- 42. OTF metering output cover*
- 43. Lens drive coupling
- 44. Depth of field preview button
- 45. Lens locating index
- 46. Accessory rail

- 47. Strap lug
- 48. Film speed selector*

† Acute-Matte designed by MINOLTA

* 503cx only.

NOTE: In the text, the positions of components are described in relation to the camera as you see it when taking a photograph, i.e. the lens is on the front, the viewfinder is in the top, and the winding crank is on the right hand side.

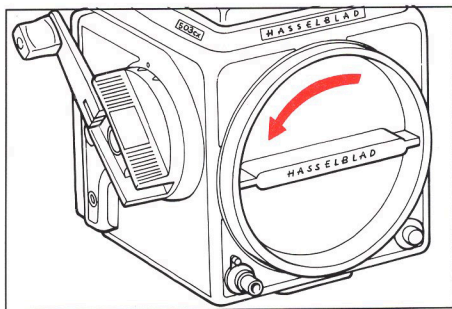

Basic Operation

This section describes the steps you must take to make the camera ready to use. You will find comprehensive information on how to operate the camera in the following sections.

With the camera, lens, and film magazine unwrapped but unassembled, ensure that the camera is cocked (i.e. the mechanism is fully wound), otherwise the circular front protective cover cannot be removed. The winding crank on the right hand side of the camera is locked if the mechanism is fully wound. If the crank is not locked, rotate it clockwise until it does lock.

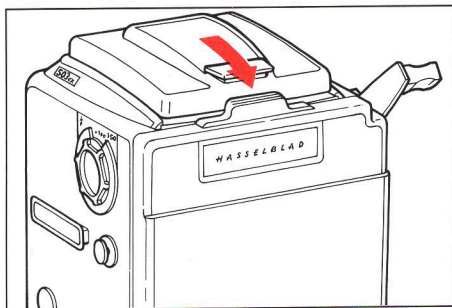

Front Protective Cover

Turn the cover (bayonet fitting) in the direction of the arrow and remove.

NOTE: The front protective cover may only be removed when the camera is cocked (fully wound).

Rear Protective Cover

Depress the catch, tilt the cover backwards, and lift it off.

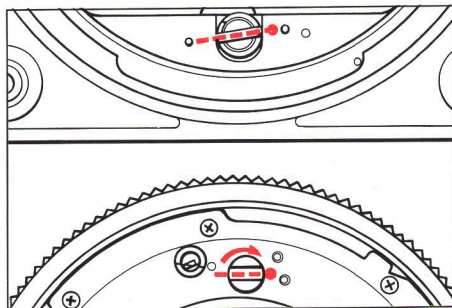

Attaching the Lens

Make sure that both camera and lens are fully cocked. The adjacent illustration shows the correct relationship between the drive shaft, the lens drive coupling and their indexes.

If the lens is not cocked, you can insert a coin in the coupling slot and rotate it clockwise until it locks (about 4/5 of a turn).

You will find that holding the camera in your left hand and the lens in your right hand, as shown in the illustration, is the easiest way of attaching the lens.

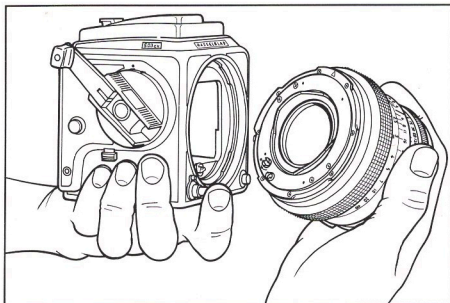

When you have aligned the red index on the lens with the one on the camera as shown in the illustration, the lens will drop easily into the bayonet fitting. You can then rotate it clockwise until it stops with a faint click as the lens catch locks it in place.

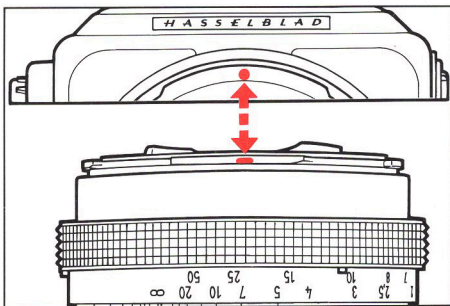

Removing the Lens

Depress the lens release button and rotate the lens counter-clockwise until it stops.

NOTE: You can only remove the lens when the camera is cocked (fully wound) and not in the pre-released mode (see page 13).

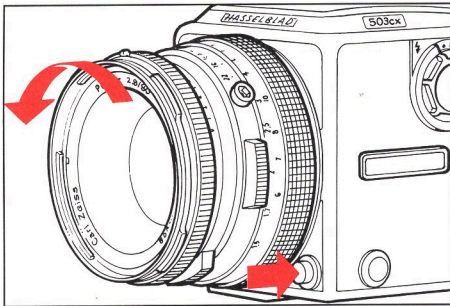

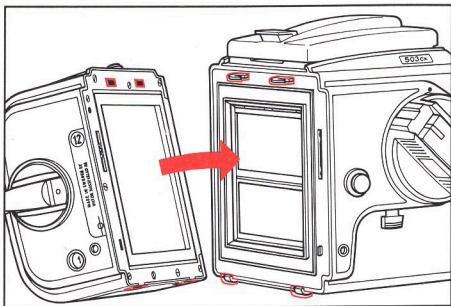

Attaching the Magazine

Ensure that the magazine slide is fully inserted, and that the indicators are white. If the indicators are not white, then refer to the instruction on page 9.

Rest the magazine on the camera's lower support hooks and make sure that it is properly located on them. Carefully swing the magazine towards the camera body and check that the camera's upper support hooks fit into the slots in the magazine. Push the magazine gently but firmly against the hooks while sliding the magazine catch button to the right.

Release the button when the magazine has made contact with the rear plate of the camera, and push it to the left to ensure that it has reached the locked position. Remove the magazine slide and the camera is ready to use.

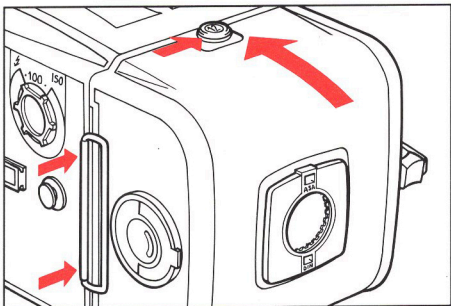

Removing the Magazine

It is advisable to have the camera cocked (fully wound) and the magazine and camera indicators both displaying white. If the magazine indicator shows a red signal then follow the instructions on the next page.

Insert the magazine slide into the magazine with the hinge towards the front of the camera.

Slide the magazine catch to the right, swing the magazine back and lift it off the lower supports.

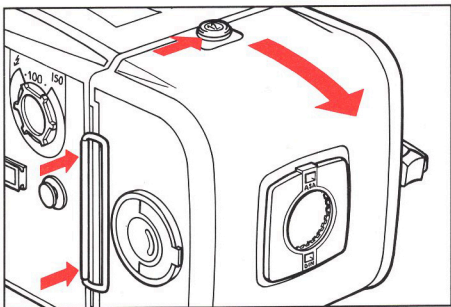

NOTE: The magazine cannot be removed without inserting the magazine slide. The slide protects the film from fogging. Note also that the camera cannot be operated when a magazine, with slide inserted, is attached to the camera.

Magazine and Camera Indicators

The indicators on the right hand side of the camera and magazine show if the particular unit is ready to operate (white) or if it has been operated (red). The golden rule is, that when you attach a magazine to a camera, the indicator colours should match – white to white, or red to red. There are only two correct combinations. This is how you rematch the indicators.

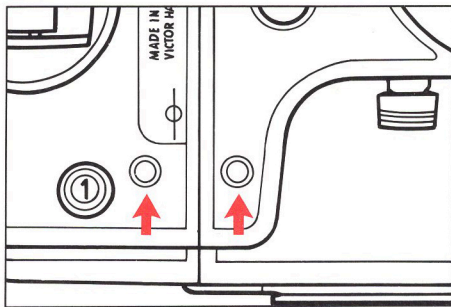

Red Magazine – White Camera

Remove the magazine from the camera.

Operate the camera – its indicator will change to red.

Attach the magazine.

Wind the camera with one full turn of the winding crank.

Both indicators will now display white.

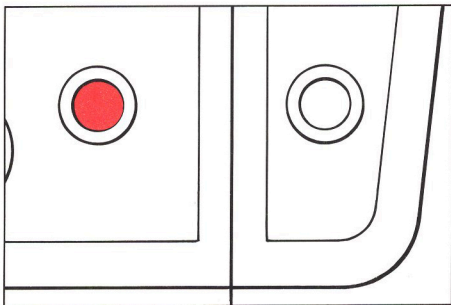

White magazine – Red Camera

Remove the magazine from the camera.

Wind the camera with one full turn of the winding crank. The camera indicator will change to white.

Replace the magazine. Both indicators will now display white.

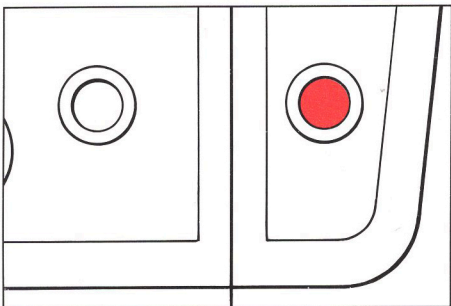

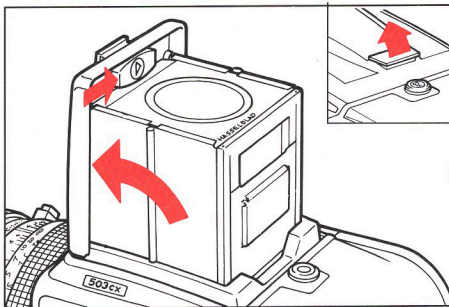

Opening the Focusing Hood

Lift the lid firmly by the grip at the rear edge, and swing it up to the vertical position.

The Built-in Magnifier

The magnifier flips up into the viewing position when the oval button inside the lid is moved in the direction of the arrow.

To fold the magnifier down simply press it back with a fingertip until it locks into the lid.

The magnifier may be changed for a correction lens. See page 21.

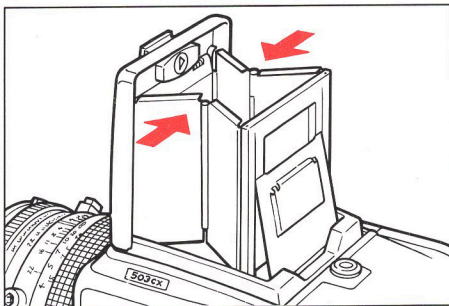

Closing the Focusing Hood

"Pinch" in the side plates at the hinge points, and fold the lid down.

The Winding Crank

One full revolution of the winding crank winds the camera, cocks the shutter and transports the film one frame.

Removing the Winding Crank

It is preferable that the camera be fully wound when the crank is being removed or replaced.

To remove the crank, you depress the latch button in the centre of the winding crank and turn the crank – **counter clockwise**.

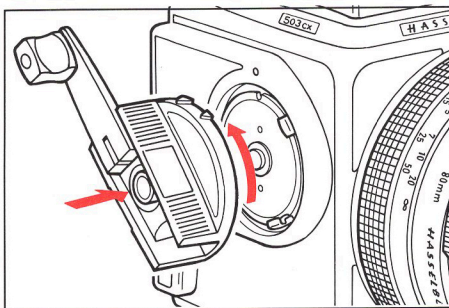

Attaching the Winding Crank

Place the winding crank against the camera's winding crank bayonet with the smaller crank index opposite the camera index. Push in the crank lightly and turn it in a clockwise direction until the larger crank index aligns with the camera index and the crank locks on.

Strap Lugs

Strap Attachment

Place the main body of the strap clip over one of the camera's strap lugs. Press down on the tip of the clip and pull back so that the strap lug slips into the opening at the tip of the clip.

Strap Removal

Lift the clip locking plate and slide the clip forward. The clip will then slide off the strap lug.

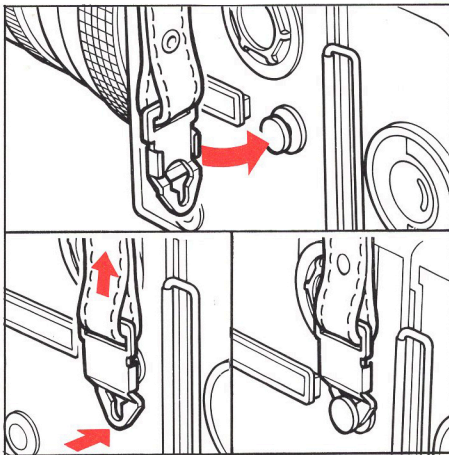

Left Hand Grip

You will find that holding the camera in your left hand with your index finger on the release button, as shown in the illustration, is most convenient when taking photographs. Your right hand is then free for focusing, setting the exposure, rewinding, and changing the lens or magazine.

Focus and Release

Before you can take a photograph, you must remove the magazine slide. The magazine will then be locked on the camera body, and the camera release button will be unlocked.

Rotate the focusing ring on the lens until you can see a sharp image of the subject in the viewfinder. You can now depress and release the release button to operate the camera.

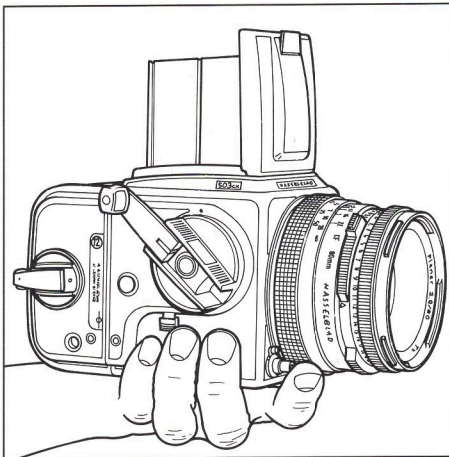

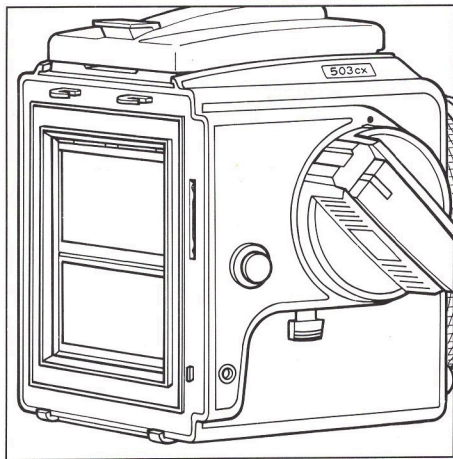

Operating Details

Exposure

As a general rule for all shutter speed settings except B, you should keep the release button depressed until the lens shutter has opened and closed fully. This is especially important at shutter speeds from 1s to 1/15s.

If you relax the pressure on the release button too soon, the auxiliary shutter will terminate the exposure prematurely (see page 14, 'Warning Signal').

You can see the auxiliary shutter, which consists of two blinds, covering the rear opening of the camera body.

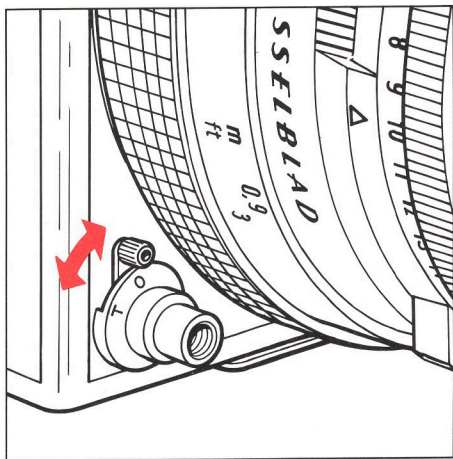

Time Exposure Lock

The time exposure lock has two settings: O, where it is disengaged and T, where the depressed release button locks in the depressed position until the lock is returned to the O setting.

The winding crank cannot be advanced until the lock is reset to O.

You can use the T setting for time exposure when the shutter is set at B.

The time exposure lock cannot be used with a cable release.

Pre-release and Cable Release

Considerable efforts have been made to reduce camera vibrations caused by moving parts in the exposure sequence. However, if you wish to avoid these vibrations completely, you can pre-release the mechanism by pushing the pre-release button upwards. This causes the following sequence: the mirror folds up, the shutter closes and remains closed, and the auxiliary shutter opens. When you subsequently press the release button, only the shutter then operates at the preset speed.

As shown in the illustration, you can also attach a cable release to further reduce vibrations.

Since the image on the focusing screen disappears in a pre-released camera, a sports viewfinder is a good way to keep track of moving subjects.

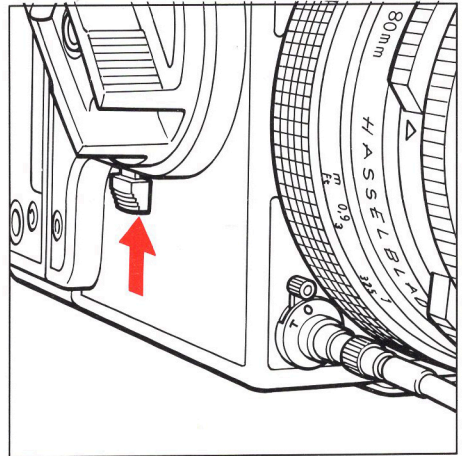

Double Exposure

As the camera has been designed to prevent accidental double exposure you will have to carry out the following procedure in order to make multiple exposures on the same frame:

1. Depress the main release button and make the initial exposure.
2. Insert the magazine slide and remove the magazine.
3. Wind the camera with one full revolution of the winding crank.
4. Replace the magazine and remove the slide.

The unit is now ready to make a second exposure on the same frame. You can make additional exposures in the same manner.

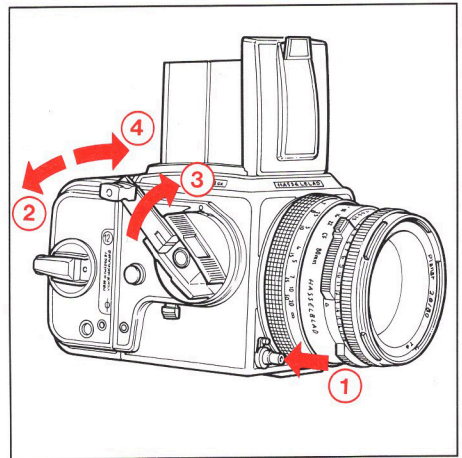

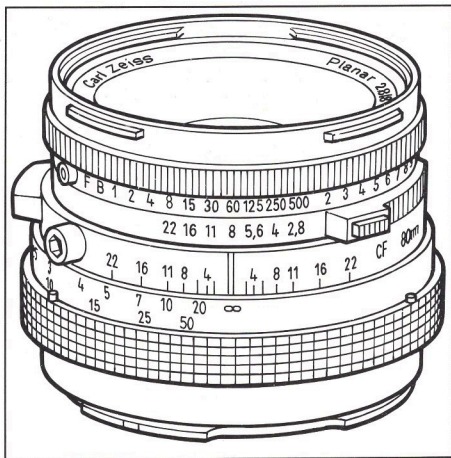

Lens and Shutter Functions

Shutter Speeds

The shutter speed selector ring is the ring located closest to the front of the lens. The desired shutter speed is set against the central lens index.

The white scale shows the shutter speeds, and the orange scale the exposure values (EV).

The green F setting is used only when the lens is attached to a Hasselblad camera in the 2000 series with a focal plane shutter. The operation of the diaphragm is not affected. The F setting can only be engaged/disengaged when the green detent button is pressed. When using the 503cx or 500C/M, the F setting will cause exposure errors since the shutter remains open.

Aperture

The aperture setting ring is the second closest ring to the front of the lens. The aperture value is also set against the central lens index.

CF lenses have an automatic diaphragm that stops down to the preset working aperture immediately prior to exposure.

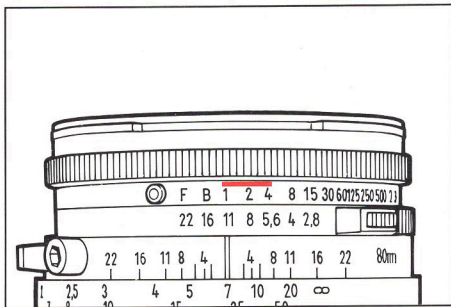

Warning Sign

On the shutter speed scale you will find a red marking opposite the 1, 1/2, and 1/4s. This is to warn you of possible exposure errors. The auxiliary shutter remains open only as long as you maintain pressure on the release button (see also page 12).

Exposure Values

The aperture and shutter speed combination set opposite the central lens index determines the exposure. Every combination of shutter speed/aperture has an equivalent exposure value (EV) which you can read and set against the red EV index on the side of the lens.

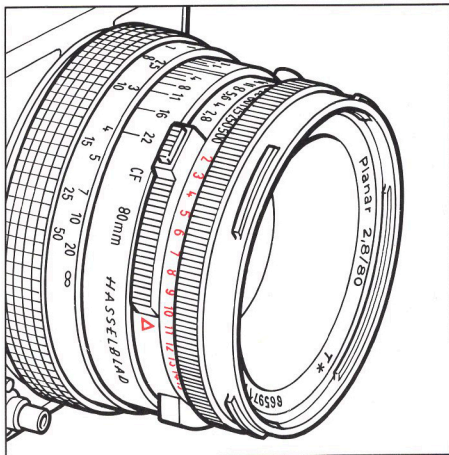

Interlocked Shutter Speed/ Aperture

If you want to change the shutter speed or aperture without changing the exposure value (EV), you can interlock the speed and aperture setting rings by holding down the interlock button which is on the right of the aperture scale. When interlocked, the rings move together, increasing or decreasing the aperture to compensate for a decrease or increase of speed respectively.

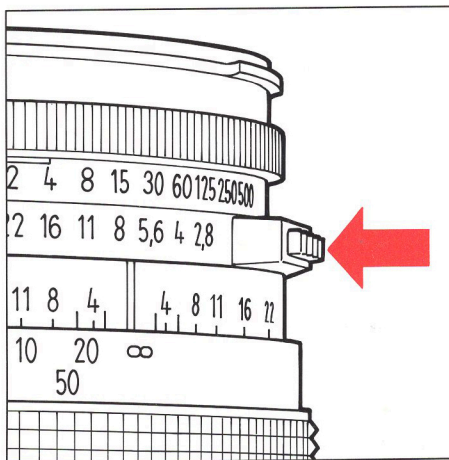

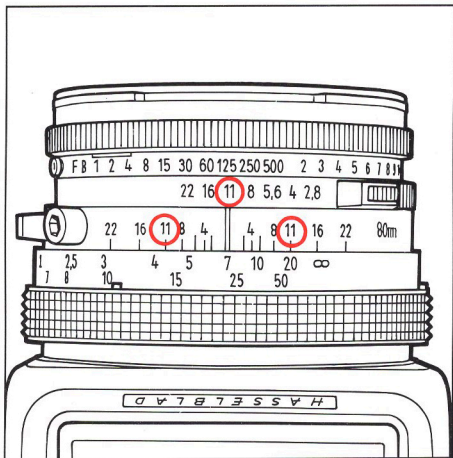

Focusing and Depth of Field

On the focusing ring are the distance scales and a knurled rubber grip which is closest to the camera body. You focus the lens by rotating the focusing ring until you obtain a sharp image of the subject in the viewfinder.

The distance between the subject and the film plane is read off the focusing ring's distance scale opposite the central lens index. The distance in metres is shown in white numerals, and the distance in feet is in orange numerals.

Objects closer or further away than the selected distance will be sharp, within certain limits. The limits of this field of sharp focus, i.e. depth of field, vary with the aperture.

The depth of field available at any given f/stop can be read off the depth-of-field scale on both sides of the central index. The rings on the illustration indicate how to read the depth of field scale with an aperture of 11.

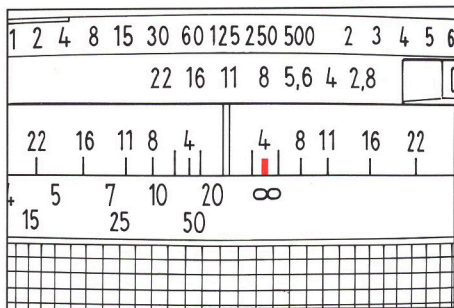

Infrared Photography

Infrared (IR) rays (wavelengths longer than 800 nanometers) are refracted to a focal plane somewhat behind the focal plane of the visible light images formed on the focusing screen. To compensate for this discrepancy, proceed as follows:

Focus as usual on the focusing screen. Then rotate the focusing ring until the distance set is opposite the red IR index.

Checking Depth of Field

To allow you to check the depth of field in the image on the focusing screen, the diaphragm can be stopped down to the preset aperture simply by sliding the manual preview button downwards until it locks into the preview position.

To release the button, and reopen the diaphragm, press in the lower section of the button.

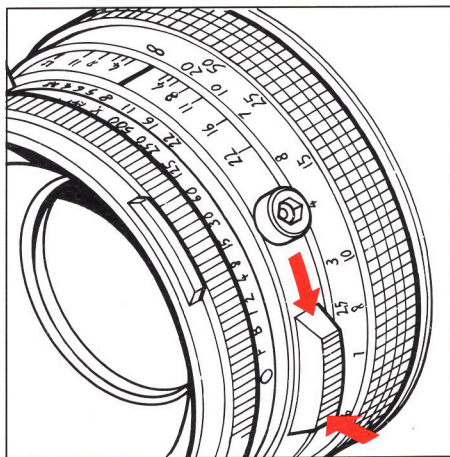

Flash Synchronization

The Hasselblad 503cx and 500C/M use lenses from the Hasselblad CF series. These lenses have built-in leaf shutters with speeds from 1 to 1/500s. Flash synchronization occurs at full shutter opening via the PC flash terminal.

Electronic flash units can be used at all shutter speeds, 1 - 1/500.

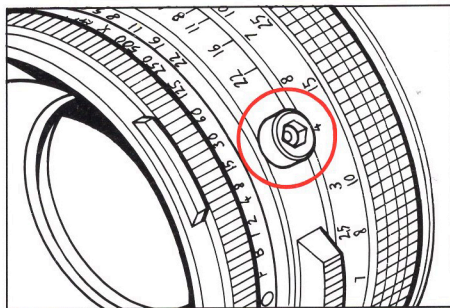

Magazine Operation

Loading the Magazine

The magazine may be loaded on, or off the camera. If it is to be loaded off the camera then the magazine slide must be inserted, its flat side towards the rear. This facilitates removal of the film holder for loading. Follow the procedure below.

- 1) Fold out the film holder key.
- 2) Turn the key **counter-clockwise** and withdraw the film holder.
- 3) An empty take-up spool should be placed under the splined knob of the spool clamp bar. Insert a roll of film under the other end of the bar, ensuring that it is turned the same way as in the illustration. Be careful to remove **all** the paper tape that surrounds a new roll of film.
- 4) Turn the film holder key **clockwise** to open the film clamp. Pull 8 - 10cm (3 - 4 in.) of paper backing off the film roll and slide the edge under the clamp.
- 5) Insert the tongue of the backing paper into the slot in the take-up spool.
- 6) Turn the splined knob **clockwise** until the arrow on the paper backing is opposite the triangular index on the spool clamp bar, but no further.
- 7) Turn the film holder key **counter-clockwise** and insert the film holder into the magazine – jiggling it a little if it does not click into place. Lock the film holder into the magazine by turning the key **clockwise**.
- 8) Fold out the film crank and rotate it **clockwise** about ten turns until it stops. Turn the crank counter-clockwise and fold it in.

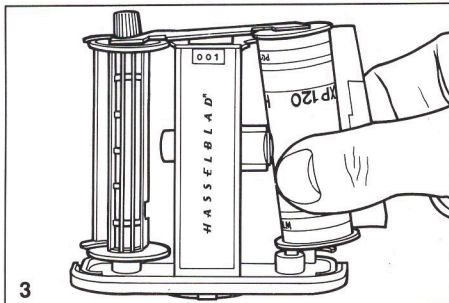
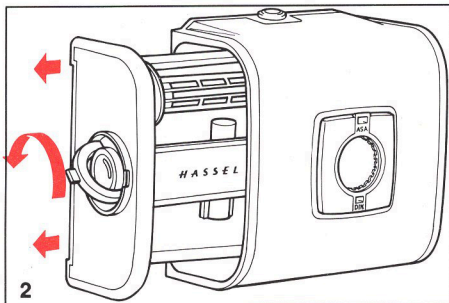
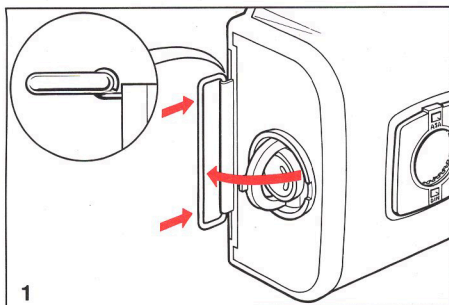

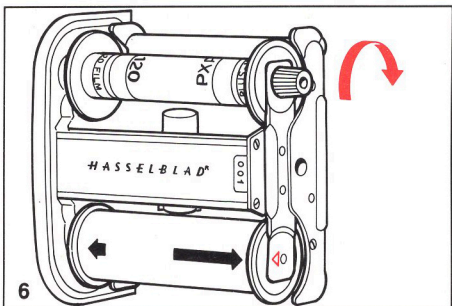
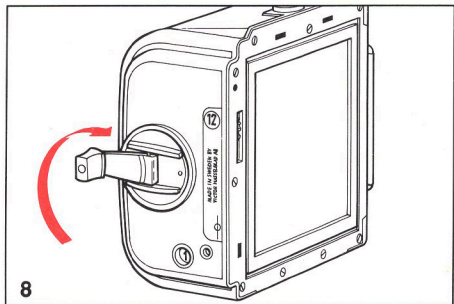
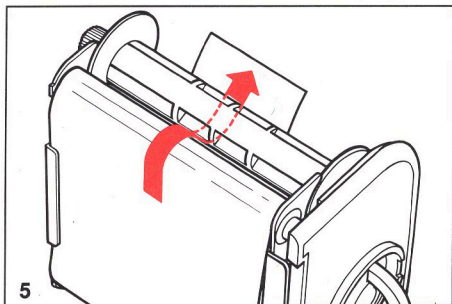
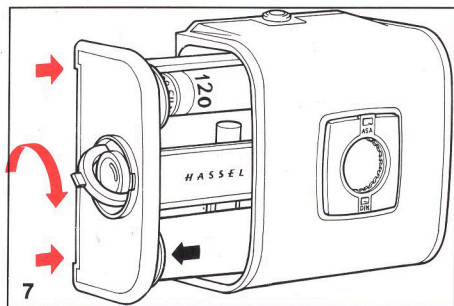
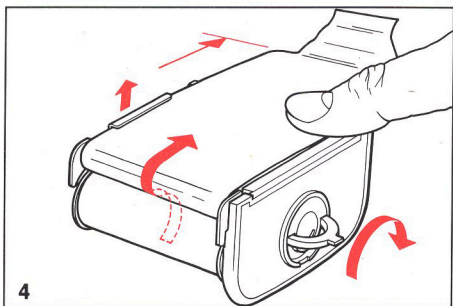

Number 1 will now be displayed in the frame counter window and the magazine is loaded – ready for use.

The magazine's film winder crank is only blocked at frame 1. A partially exposed film may be wound off at any frame thereafter.

The frame counter is automatically reset when the film holder is withdrawn from the magazine.

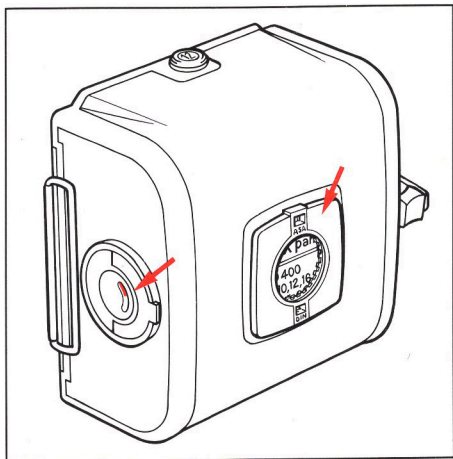

Load Status and Film Type Indicators

In the centre of the roll holder key is a crescent shaped indicator that displays white when the film is loaded into the magazine, and progressively changes to red as the film is wound on. A completely red indicator shows that either the final frame is exposed, or that the magazine is empty.

The film indicator at the rear of the magazine can be set to the sensitivity of the film in use – in ISO (ASA) or DIN.

The indicator folds out to accept the end flap of a film box informing you of film type, as well as sensitivity.

Removing Film from the Magazine

When the last frame has been exposed, and wound on, the magazine is blocked for further release.

Wind off the film by folding out the film winding crank, and rotating it clockwise until you can feel the film leave the supply spool.

You can now withdraw the film holder from the magazine and remove the exposed film.

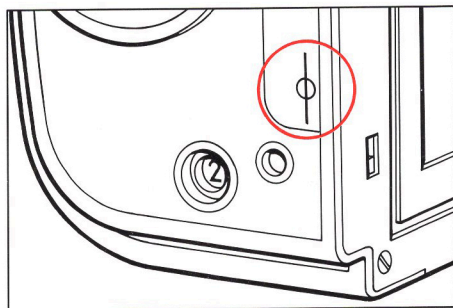

Film Plane Index

The Film Plane Index on the right hand side of the magazine body indicates the position of the film plane to facilitate accurate determination of the subject-to-film distance, which is very important in close-up photography.

Viewfinder System

Changing the Viewfinder

The film magazine or rear cover must be detached before the focusing hood or other viewfinder can be removed. The focusing hood should be folded down before being removed, to prevent it from being damaged.

Remove the hood by sliding it to the rear in its guide slots.

Slide the replacement finder into the slots and push it forward.

Attach a magazine or rear cover to the camera.

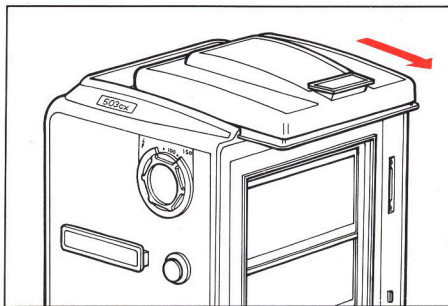

Changing the Magnifier

The focusing hood has an easily interchangeable magnifier that allows you to match the viewfinder with your eyesight.

Lenses with diopter correction from +3 to -4 are available, and are easily interchanged as follows:

Remove the focusing hood from the camera and open it by lifting the lid firmly at the rear edge.

Bring the magnifier to the viewing position by moving the oval button in the direction of the arrow.

Push the magnifier half way back down to its folded position.

Grip the lower edge of the magnifier between thumb and forefinger (through the underside of the hood), and pull firmly.

Insertion of the replacement lens is the reverse of the above procedure.

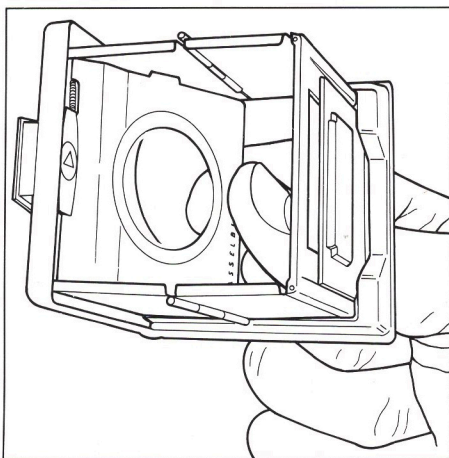

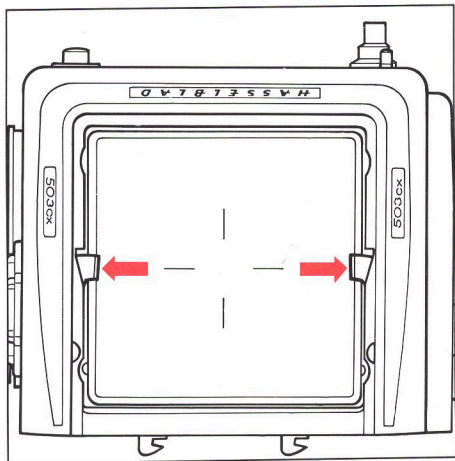

Changing the Focusing Screen

The screen is easily interchanged without the requirement of special tools.

Detach the magazine and viewfinder.

Slide the screen latches to the side.

Cup your hand over the screen, and invert the camera.

The screen will now drop into your hand.

Insert the replacement screen, ensuring that the smooth flat side of the frame is uppermost, and that all four corners are seated on the support pins.

It is not necessary to return the screen latches. This is done automatically when the viewfinder is replaced.

In the Hasselblad Product Catalogue you will find the entire range of focusing screens of different designs for various applications.

The 503cx model is equipped with an Acute-Matte[†] focusing screen which provides a considerable increase in the brightness of the focusing image when compared with the ground-glass screen used in the 500C/M model. You will find instructions on how to adjust the PME and PME 3 Meter Prism Viewfinders to compensate for the light level differences on the different focusing screens on page 24.

[†] Acute-Matte designed by MINOLTA.

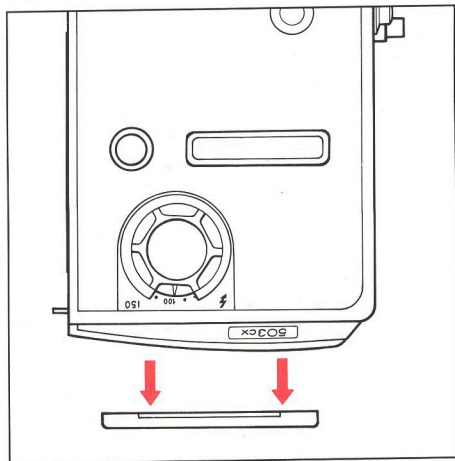

PME 3/PME Meter Prism Viewfinder Adjustments

Since the Hasselblad Meter Prism Viewfinders measure the light level on the focusing screen they have been calibrated at the factory to give an accurate reading with one particular type of screen. If that focusing screen is replaced with another type which gives a different light level under the same ambient conditions, the meter has to be adjusted to compensate for the difference.

The PME 3 and PME meter viewfinders are basically the same design but are differently adjusted from the factory. The PME 3 type is adjusted to the brighter Acute-Matte[†] screen in the 503cx camera while the previous PME type is adjusted to the lower light level of the Ground-Glass screen (Cat. No. 42161) and similar, comparable screens, such as Split Image (42188), Central Grid and Split Image (42218), Checked and Central Grid (42250) and Fine Line (42285). The Plain Glass Screen (42200) is not suitable for TTL measuring.

The distinction between the two viewfinder types is indicated by the designation PME 3 on the rear of the viewfinder body above the eyepiece. The PME has no designation.

The ways of compensating for alternative usage of the meter viewfinders are shown in the charts on the next page.

[†] Acute-Matte designed by MINOLTA.

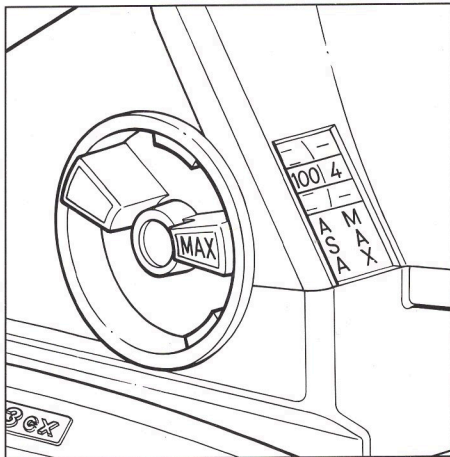
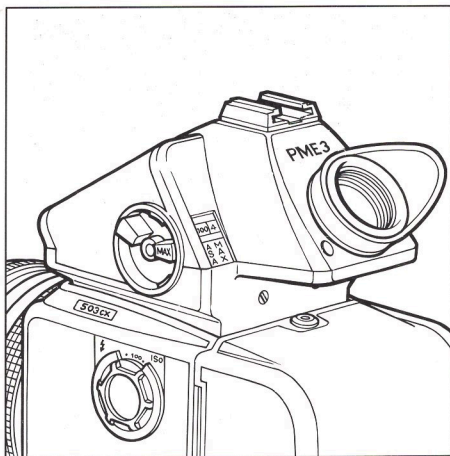

A. Acute-Matte† focusing screen, combined with:

Viewfinder model	Action required to obtain a correct EV value
PME 3	No action required.
PME	<p><u>Reduce</u> the ASA/ISO setting to half the film speed value as indicated on the film package</p> <p>or</p> <p><u>Increase</u> the MAX lens aperture setting one full step</p> <p>or</p> <p><u>Reduce</u> the EV reading one full step when setting it on the lens EV scale.</p>

B. Ground-glass or similar focusing screen, combined with:

Viewfinder model	Action required to obtain a correct EV value
PME 3	<p><u>Increase</u> the ASA/ISO setting to twice the film speed value as indicated on the film package</p> <p>or</p> <p><u>Reduce</u> the MAX lens aperture setting one full step</p> <p>or</p> <p><u>Increase</u> the EV reading one full step when setting it on the lens EV scale.</p>
PME	No action required.

† Acute-Matte designed by MINOLTA.

503cx only

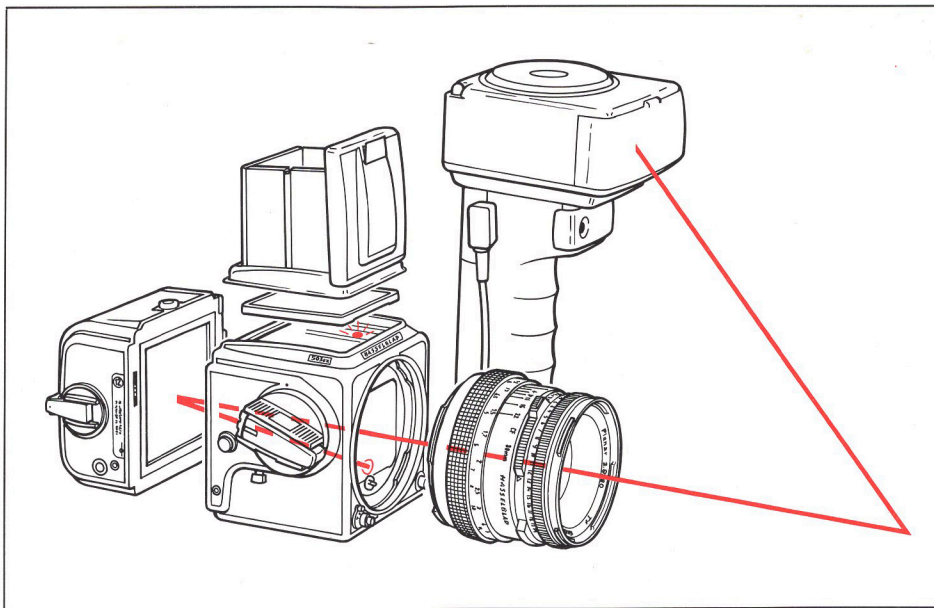

Automatic Flash Control

The camera's built-in flash sensor and electronics measure the light reflected from the central portion of the film surface, a circle with a diameter of 40mm. The metering system is connected to a selector for setting film speed, and with an SCA 390 or 590 adapter it provides a control signal which is transmitted to a flash unit conforming to the corresponding System SCA 300 or 500. The

signal regulates the flash unit, cutting off the flash when the exposure is correct. Under the left edge of the focusing screen an indicator light shows when the flash is ready to be operated and then confirms if the amount of light emitted was sufficient to provide a correct exposure. The flash unit powers both the camera's electronics and the adapter.

503cx only

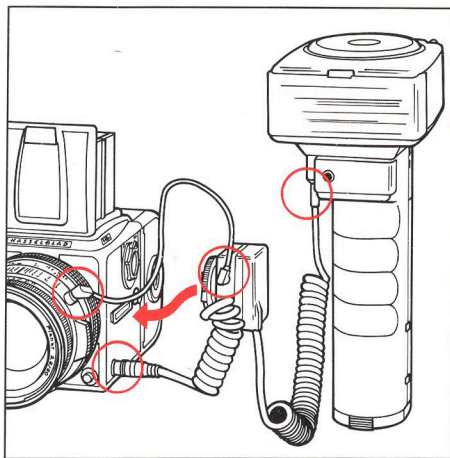
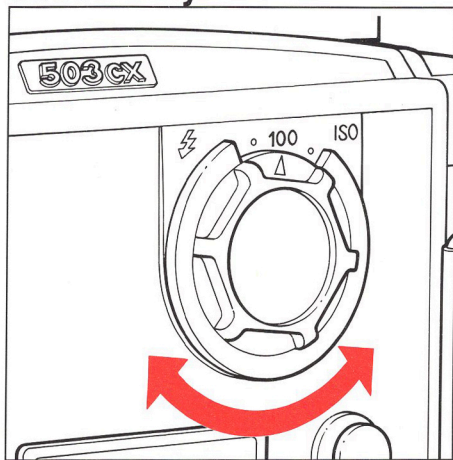

Attaching the Hasselblad Flash Adapters SCA 390 and SCA 590

For hand-held flash units, either adapter is attached as shown in the illustration above:

- the 6-pole contact from the spiral cord is connected to the camera's side socket
- the sync cord is connected from the adapter to the PC flash terminal of the lens
- the connecting cord is attached to the hand-held unit.

Setting the Film Speed

The film speed is set via the ISO selector. This is divided into ISO/ASA settings from 16 - 1000. The equivalent in DIN ratings can be found using the table below. Certain films require compensation for differences in reflection. In these instances, the compensation is made by changing the film speed selector setting. The amount of compensation has to be determined by experiment.

NOTE: The flash unit must always be set to the "TTL" position.

ISO/ASA	16	25	40	64	100	200	400	800											
DIN	13	14	15	16	17	18	19	20	21	22	23	24	25	26	27	28	29	30	31

503cx only

Viewfinder Signal

This indicator located under the left edge of the focusing screen displays two different signals, both shown in a red glowing light. The indicator is only in operation when the camera is used with flash adapters SCA 390 or 590 and a flash unit that conforms to the corresponding System SCA 300 or 500.

Ready Signal

A steady red light indicates that the flash unit is charged and ready to be fired.

Result Signal

A blinking red light that occurs for just over a second after exposure indicates that the flash has emitted the right amount of light for a correct exposure. After the blinking signal, the indicator returns to the ready signal when the flash unit is once again fully recharged.

No Result Signal

This indicates that the flash emitted was not sufficient for correct exposure. The aperture

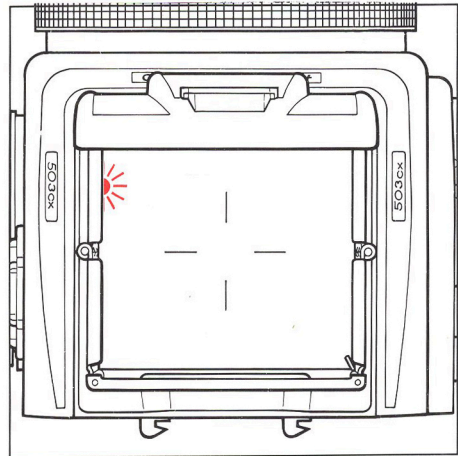

must then be opened or the flash distance to the subject must be reduced. Changing to a faster film is also a possibility.

The Ready Signal will appear after a short but variable length of time depending on the condition of the batteries.

Please refer to your flash unit's operating instructions for more information about other functions when using automatic flash light metering that conforms to System SCA flash photography with flash sensors, or with non-automatic flash units.

Accessories

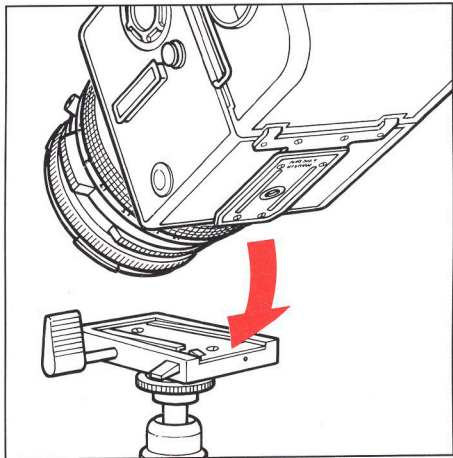

Accessory Mounts

On the bottom of the camera body a 1/4 in. thread tripod socket is located in the centre of the quick coupling plate. The plate and socket accept flash gun brackets and the plate also fits and easily locks into the Hasselblad Tripod Quick-coupling.

If you own tripods and other accessories with 3/8 in. screws we recommend you to purchase the Tripod Quick-coupling which has both 1/4 and 3/8 in. sockets and provides an easily operated, fast and reliable tripod connection.

Should you prefer not to obtain a Quick-coupling, your Hasselblad distributor can, upon request provide a replacement 3/8 in. socket together with installation instructions.

On the left hand side of the camera body in front of the strap lug there is an accessory rail for the Hasselblad Sports Viewfinder and other accessories. The lenses accept filters and lens shades on the front bayonets.

Hasselblad Accessory Chart

The accessory chart on the opposite page indicates the wide range of accessories available within the Hasselblad System. Please refer to the Hasselblad Product Catalogue for complete information on the entire Hasselblad Camera System.

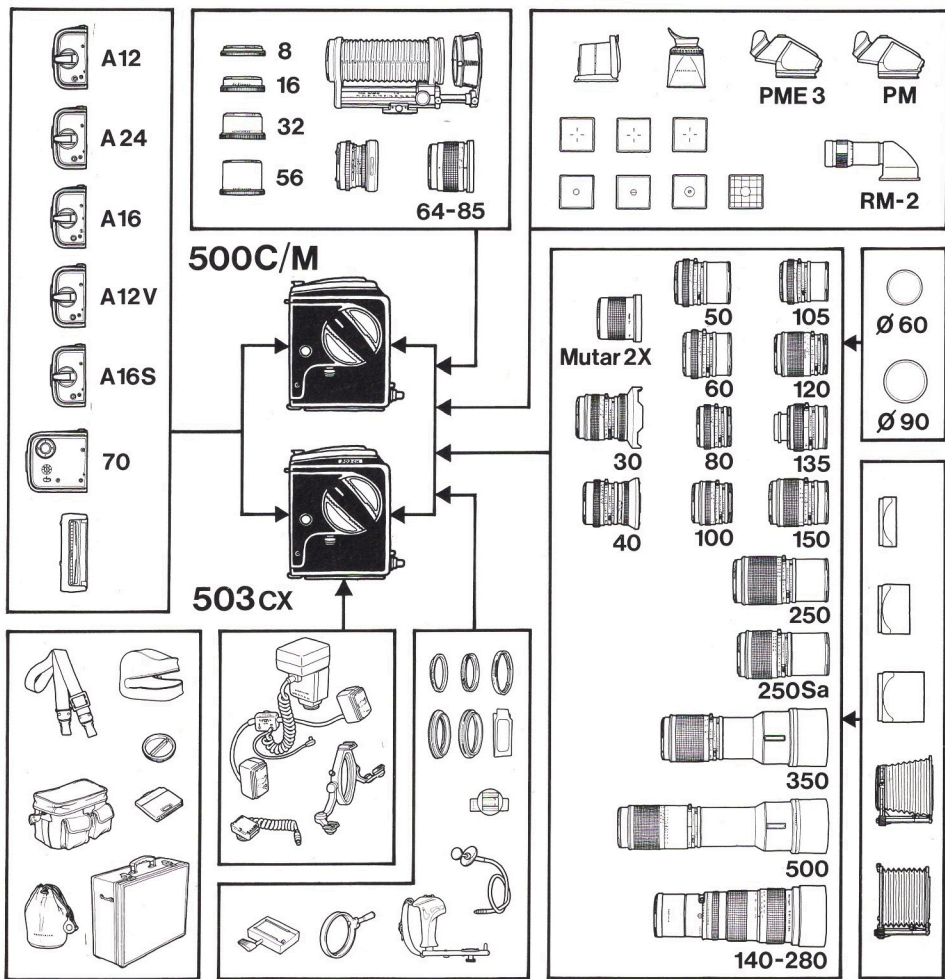

Technical Specifications and Equipment 503cx

Camera type:	Single-lens reflex camera with 6 x 6cm (2 1/4 x 2 1/4in.) film size (max.). Interchangeable lenses, film magazines, viewfinders, and focusing screens.
Design:	Mechanical, with an aluminium alloy camera body shell cast in one piece.
Viewfinders:	Folding focusing hood. The camera can accept different types of focusing screens, prism viewfinders with or without a built-in light meter, magnifying hood, or sports viewfinder.
Film advance:	Manual advance with simultaneous shutter cocking. The winding crank can be replaced with a knob with built-in exposure meter.
Flash control:	OTF/TTL-measurement. ISO 16 - 1000 with flash adapters SCA 390 or SCA 590 for connection with flash units from the SCA 300 or SCA 500 systems respectively. Measuring area within Ø40mm in the centre of the film surface.
Tripod socket:	1/4 in. socket thread and tripod plate for quick-coupling attachment.
External dimensions:	Camera body only – see opposite. Camera body with 80mm Planar CF lens and film magazine A12: 180 L x 114 W x 107mm H (7 x 4 1/2 x 4 3/16 in.).
Weight:	Camera body only: 610g (1lb 5 1/3oz). The camera body with 80mm Planar CF lens and film magazine A12: 1510g (3lb 5 1/3oz).
Focusing screen:	Hasselblad Acute-Matte [†] focusing screen.

The camera body (chrome model, product no. 10026 or black model, product no. 10172), comes with focusing hood, focusing screen, winding crank, neck strap, and front and rear protective covers.

For comprehensive information on accessories please refer to the Hasselblad Product Catalogue. Hasselblad reserve the right to make changes in the published specifications without prior notice.

[†] Acute-Matte designed by MINOLTA.

Technical Specifications and Equipment 500C/M

Camera type: Single-lens reflex camera with 6 x 6cm (2 1/4 x 2 1/4in.) film size (max.). Interchangeable lenses, film magazines, viewfinders, and focusing screens.

Design: Mechanical, with an aluminium alloy camera body shell cast in one piece.

Viewfinders: Folding focusing hood. The camera can accept different types of focusing screens, prism viewfinders with or without a built-in light meter, magnifying hood, or sports viewfinder.

Film advance: Manual advance with simultaneous shutter cocking. The winding crank can be replaced with a knob with built-in exposure meter.

Tripod socket: 1/4 in. socket thread and tripod plate for quick-coupling attachment.

External dimensions: As 503cx – see page 31. Camera body with 80mm Planar CF lens and film magazine A12: 180 L x 114 W x 107mm H (7 x 4 1/2 x 4 3/16 in.).

Weight: Camera body only: 600g (1lb 5oz). The camera body with 80mm Planar CF lens and film magazine A12: 1500g (3lb 5oz).

Focusing screen: Hasselblad ground-glass focusing screen.

The camera body (chrome model, product no. 10022 or black model, product no. 10170), comes with focusing hood, focusing screen, winding crank, neck strap, and front and rear protective covers.

For comprehensive information on accessories please refer to the Hasselblad Product Catalogue.

Hasselblad reserve the right to make changes in the published specifications without prior notice.

Camera Body Dimensions

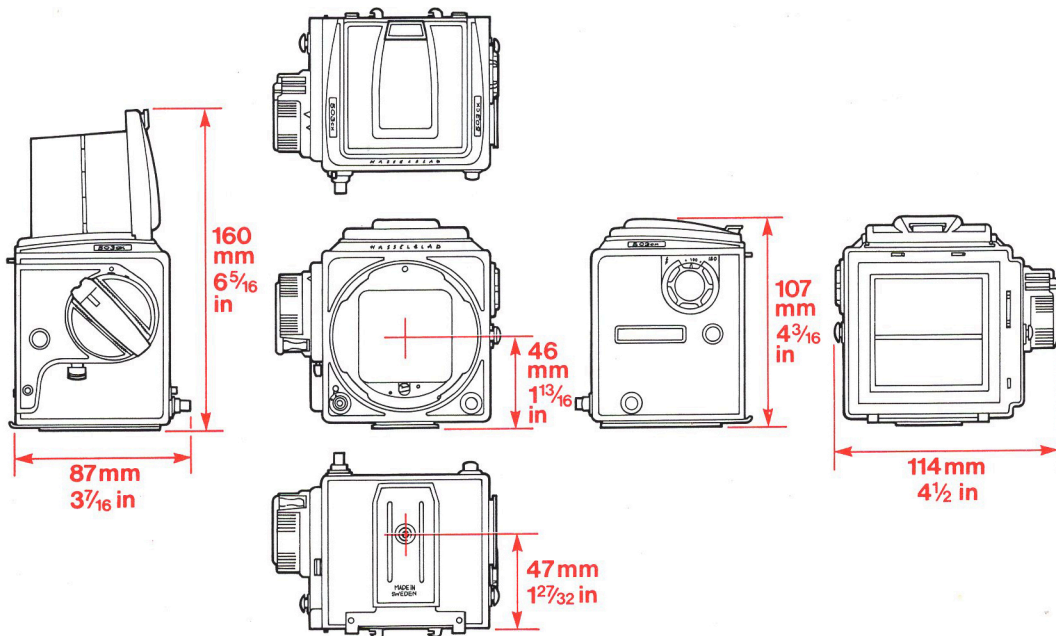

Troubleshooting

Your camera is built to give long and trouble-free service. If however you encounter any operating difficulties because you are not familiar with the Hasselblad camera system, the following table may help to resolve them.

PROBLEM	POSSIBLE CAUSE	REMEDY
You cannot operate the release button	The magazine slide is still in place The film is finished The camera is in the released position	Remove the slide Load a new film Wind the camera
The release button remains depressed	The time exposure lock is in the T-position	Return the lock to the O-position
There is no image on the focusing screen	The camera is in the pre-released or released position	Release and/or wind the camera
You cannot remove the front protective cover	The camera is in the pre-released or released position	Release and/or wind the camera
You cannot attach the lens	The camera is in the pre-released or released position The lens shutter is in the released position	Release and/or wind the camera Cock the lens shutter
You cannot remove the lens	The camera is in the pre-released or released position	Release and/or wind the camera
You cannot remove the magazine	The magazine slide is not fully inserted	Insert the magazine slide until it is positively stopped

Camera Care, Service and Guarantee

Camera Care

Your Hasselblad camera is designed to withstand the rigours of professional use in most environments. In order to avoid the possibility of damage however, the camera should be protected from the following.

Extremes of temperature. High temperatures can have an adverse effect on both the film and the camera. For this reason you should not keep your camera in places where it will get hot, such as in direct sunlight or on a shelf above a radiator. Frequent rapid and severe temperature changes can cause problems such as the corrosion of electrical contacts, and should therefore be avoided.

Dust and grit. You should take care to prevent dirt of any kind from getting into your camera. When taking photographs in coastal areas for example, the camera should be protected from sand and salt water spray.

You can blow away any dust on the lens glass, magnifier or focusing screen, or wipe it off gently with a soft cloth if necessary. Smears on the lens glass should be removed with a high quality lens cleaning solution on a tissue. Be careful not to scratch the lens or touch any of the glass surfaces with your fingers. The surface of the mirror is coated and can be blown clean but should not be wiped.

Impact. Your camera can be damaged by severe physical shocks. While you will obviously try not to drop it, you should also take care not to leave it where it can fall or be knocked to the ground, or roll about, as on the back seat of a car for example.

Service

Faultless camera performance is essential to the professional photographer. It is therefore advisable to check that your camera is functioning correctly before an important assignment. You should also return your camera to a Hasselblad service centre for occasional checking and preventive maintenance. If your camera is used constantly and intensively, exposing for example hundreds of rolls of film per week, check-ups every six months are recommended. Hasselblad service centres have the expert staff and specialized equipment necessary to ensure that your camera remains in perfect working order.

Guarantee

Provided that you bought your camera from an authorised Hasselblad outlet, it is covered by an international guarantee for one year. The guarantee document and a registration card are supplied with the camera. Keep the guarantee document carefully, but fill in the registration card and return it to your Hasselblad distributor.

VICTOR HASSELBLAD AKTIEBOLAG
Box 220, S-401 23 Göteborg, Sweden