

Price List

EFFECTIVE DATE:
APRIL 1, 1984

GSMO & CP-16 16mm Camera Systems



CP-16R/A

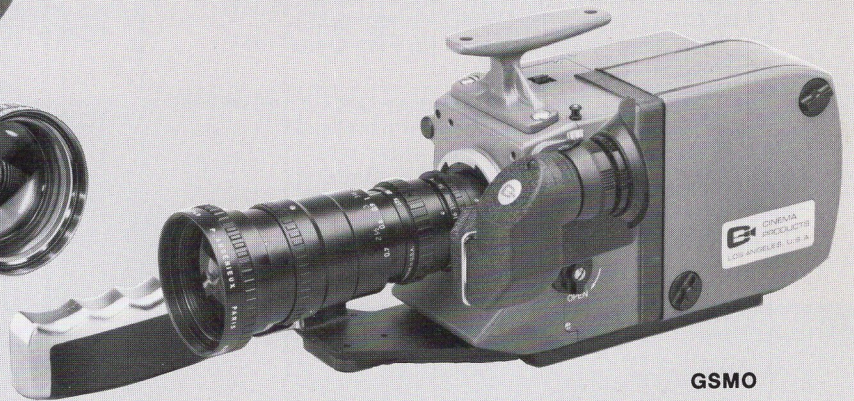

GSMO

and U/F-16 Upright Flatbed Editing Consoles



U/F-16

cinema  **products**
CORPORATION

Technology In The Service Of Creativity

2037 Granville Avenue, Los Angeles, California 90025
Telephone: (213) 478-0711 • (213) 477-1971 • Telex: 69-1339

GSMO REFLEX CAMERA SYSTEMS

ORDER CODE	DESCRIPTION	PRICE
1C505	GSMO Camera Body (only) , with integral crystal - controlled motor (sync speeds 24/25 fps, plus a range of variable speeds), fiber optics viewing screen, autoslate/pilotone system. Designed for double system sound.	\$8500.00
1C508	GSMO Camera System. Includes GSMO Camera Body, with Dual Purpose Viewfinder; (2) NC-4 Battery Packs; (2) NCC-6 Chargers; (1) GSMO Handgrip; (2) 400 ft. Coaxial Magazines with (2) Film Gate Assemblies.	15,500.00
1C509	GSMO Camera System. Includes: GSMO Camera Body, with Orientable Viewfinder; (2) NC-4 Battery Packs; (2) NCC-4 Battery Packs; (2) NCC-6 Chargers; (1) GSMO Handgrip; (2) 400 ft. Coaxial Magazines with (2) Film Gate Assemblies.	16,250.00
1C523	GSMO Camera System. Includes: GSMO Camera Body, with Exposure information (LED) Display visible in the viewfinder; Dual Purpose Viewfinder; (2) NC-4 Battery Packs; (2) NCC-6 Chargers; (1) GSMO Handgrip; (2) 400 ft. Coaxial Magazines with (2) Film Gate Assemblies.	17,400.00
1C524	GSMO Camera System. Includes: GSMO Camera Body, with Exposure information (LED) Display visible in the viewfinder; Orientable Viewfinder; (2) NC-4 Battery Packs; (2) NCC-6 Chargers; (1) GSMO Handgrip; (2) 400 ft. Coaxial Magazines with (2) Film Gate Assemblies.	18,000.00

GSMO/CP-16R Reflex Camera/Zoom Lens Packages

NOTE: When ordering any of the above Reflex Camera Systems *with*:

1N319	Angenieux 10-150mm BCP: <i>add</i>	4775.00
1N312	Angenieux 12-120mm BCP: <i>add</i>	3800.00
1N317	Angenieux 9.5-57mm BCP: <i>add</i>	4600.00
1N321	Angenieux 17.5-70mm BCP (includes retro-zoom attachment for conversion to 12.5-50mm): <i>add</i>	1750.00
1N332	Angenieux 16-44mm T1.3 BCP: <i>add</i>	6300.00
1N328	Angenieux 12-240mm BCP: <i>add</i>	11,000.00

NOTES:

TO ORDER: Reference the designated camera order code and the designated lens code numbers.

NOTE: All Angenieux zoom lenses ordered with CP-16 or CP-16A cameras are delivered with triple slotted C-sleeve installed on C-cup at no charge.

IMPORTANT: When ordering CP-16R reflex or CP-16 non-reflex camera models—Please SPECIFY: 1) 24 fps or 25 fps; 2) Footage Counter or Meter Counter.

NOTE: Whenever possible, order camera options and modifications at same time as original camera order to avoid retrofit charges.

NOTE: Special Camera/Lens Packages are available to meet individual zoom and prime lens requirements. Please inquire.

Prices & Specifications Subject to Change Without Notice.
Prices F.O.B. Factory (Los Angeles, California).

CP-16R & CP-16R/A REFLEX CAMERA SYSTEMS

ORDER CODE	DESCRIPTION	PRICE
1C316	CP-16R Camera System , (<i>without</i> sound system). With integral crystal-controlled motor; sync speeds 24 or 25 fps, plus a range of variable speeds; fiber optics viewing screen; information display indicators (LEDs) visible in the viewfinder. Supplied with: (1) standard viewfinder; (2) NC-4 battery packs; (2) NCC-6 chargers; (1) lens cavity cap; (2) gelatin filter holders; (1) magazine take-up belt; (1) magazine well cover plate; (1) front handgrip; (1) handgrip connector cover plate; (4) magazine lock mount studs. <i>Includes</i> Auxiliary Side Cover (with 8-pin connector). Designed for single/double system sound.	\$12,600.00
1C317	CP-16R Camera System , (same as 1C316) <i>less</i> Standard Viewfinder, but <i>with</i> Orientable Viewfinder.	13,350.00
1C372	CP-16R/A Camera System , (same as 1C316) <i>less</i> Auxiliary Side Cover, but <i>with</i> built-in Crystasound Amplifier.	14,000.00
1C375	CP-16R/A Camera System , (same as 1C372) <i>with</i> built-in Crystasound Amplifier, and 3XL-2AZ Magnetic Head.	14,600.00
1C376	CP-16R/A Camera System , (same as 1C375) <i>less</i> Standard Viewfinder, but <i>with</i> Orientable Viewfinder.	15,350.00
1C381	CP-16R/A Camera System , (same as 1C372) <i>with</i> built-in Crystasound Amplifier, 3XL-2AZ Magnetic Head, RE50 Microphone, and CP Headphone set.	14,800.00
1C385	CP-16R/A Camera System , (same as 1C375) <i>less</i> Standard Viewfinder, but <i>with</i> Orientable Viewfinder and Semi-Automatic Exposure Control.	17,250.00

CP-16 & CP-16/A NON-REFLEX CAMERA SYSTEMS

1C216	CP-16 Camera System , (<i>without</i> sound system). With integral crystal-controlled motor. Supplied with: (2) NC-4 battery packs; (2) NCC-6 chargers; (1) lens cavity cap; (2) gelatin filter holders; (1) magazine take-up belt; (1) magazine well cover plate; (1) front handgrip; (1) handgrip connector cover plate; (4) magazine lock mount studs. <i>Includes</i> Auxiliary Side Cover (with 8-pin connector). Designed for single & double system sound.	4400.00
1C272	CP-16/A Camera System , (same as 1C216) <i>less</i> Auxiliary Side Cover, but <i>with</i> built-in Crystasound Amplifier.	5775.00
1C275	CP-16/A Camera System , (same as 1C272) <i>with</i> built-in Crystasound Amplifier, and 3XL-2AZ Magnetic Head.	6475.00
1C281	CP-16/A Camera System , (same as 1C272) <i>with</i> built-in Crystasound Amplifier, 3XL-2AZ Magnetic Head, RE50 Microphone, and CP Headphone set.	6650.00

CP-16 Non-Reflex Camera/Zoom Lens Package

NOTE: When ordering any of the above Non-Reflex Camera Systems *with*:

1N123	Angenieux 9.5-57mm AV30 (1" viewfinder): <i>add</i>	2882.50
-------	---	---------

CP-16/A & CP-16R/A CRYSTASOUND RECORDING SYSTEM

ORDER CODE	DESCRIPTION	PRICE
1M178	Crystasound Amplifier (includes 3-position "on-off/auto-on" switch), for fitting to existing CP-16 or CP-16R.	\$ 2050.00
1M193	Crystasound 3XL-2AZ Magnetic Head (including retaining clip).	750.00
1M195	3XL-2AZ Magnetic Head (including retaining clip), with the <i>trade-in</i> of any existing magnetic head.	550.00
1M196	Rebuild of <i>existing</i> 3XL-2AZ or Auricon TR-RPH-11 magnetic heads.	350.00
1M236	RE50 Microphone—with built-in windscreen (includes 15 ft. cable).	160.00
1M257	CP Micro-Mike, subminiature microphone with 12' cable, Vega jack termination, tie clip (supplied in case); and with 1M258 Balancing Transformer with 3-pin female termination. For use with standard wireless transmitters, Crystasound Amplifier or Nagra recorder.	225.00
1M258	Balancing Transformer, as spare. (For use with 1M256 or 1M257.)	90.00
1M305	CP Microphone Boom (Fishpole), extends from 2' to 6'8". (Complete with microphone stud and internal 10' length of wire with two 3-pin female terminations.)	115.00
1M232	CP Headphone Set.	55.00
1M186	Auxiliary Side Cover (with 8-pin connector), as spare.	400.00
1M222	Auxiliary Mixer—Model 6C (including 1J187 Connecting Cable).	1750.00
1M202	Adapter for Crystasound Tape Feed-out.	135.00

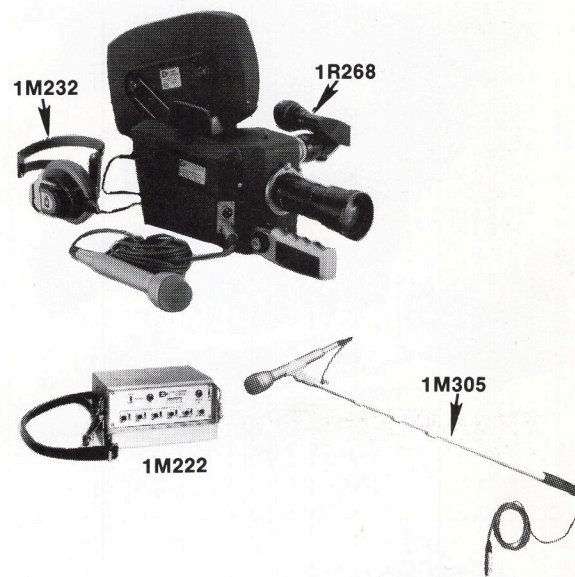
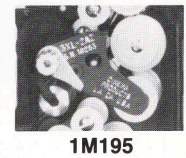
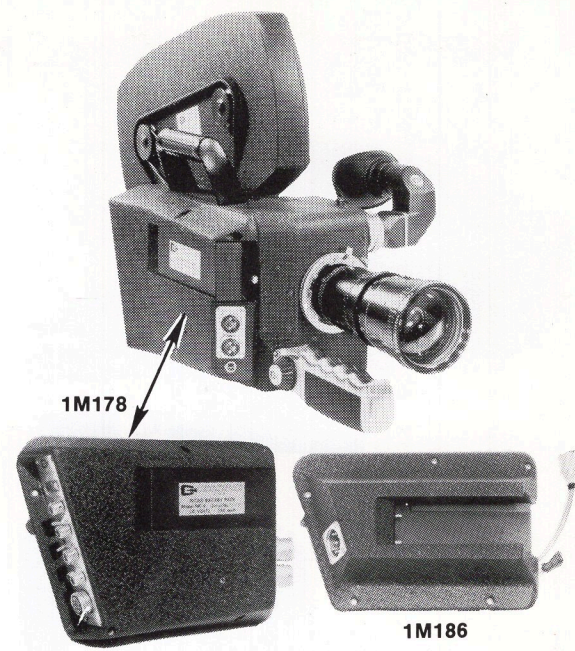
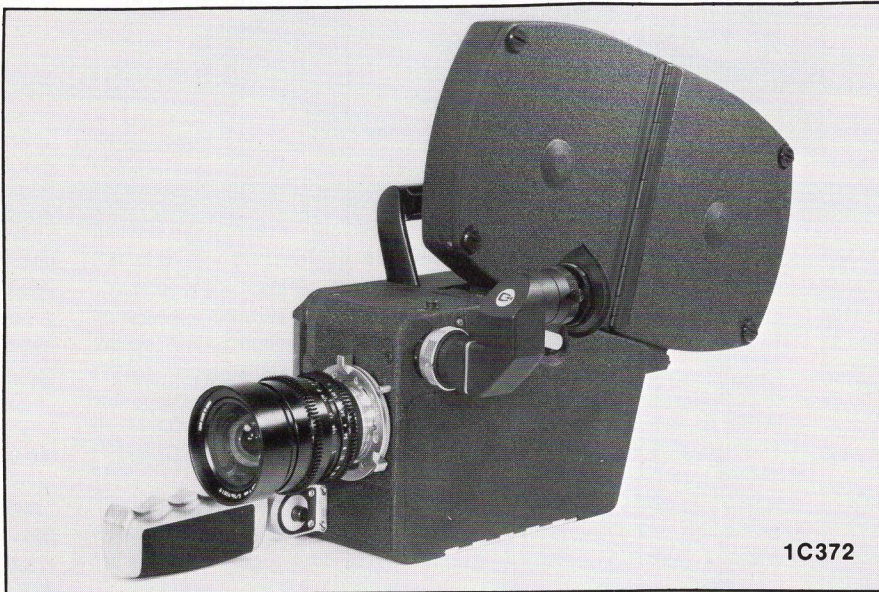

Crystalink Wireless Transmitter/Receiver System

1M264	Crystalink Wireless Receiver & Transmitter-Model CL-3. Supplied with Swintek Model 50A Transmitter, plus 1J160 cable, 1M269 input adapter, and 1L236 dovetail for mounting receiver to CP-16/A or CP-16R/A cameras (does not include microphone).	2350.00
1M260	Crystal Front End for CL-3, as <i>option</i> .	450.00
1M266	Swintek Model 50A Transmitter, for CL-2 and CL-3 (as additional unit).	880.00
1M276	Mercury Battery (12.6V; Mallory #TR-289), for use with Vega Model 54 Microphone/Transmitter, as spare.	12.00
1M256	CP Micro-Mike, subminiature microphone with 4½ ft. cable, Vega jack, tie clip; (supplied in a case). For use with Crystalink CL-1, CL-2 and CL-3, and other wireless transmitters.	180.00
1M269	Input Adapter for Crystalink CL-2 and CL-3, as spare. (Note: Also serves as option in Cinevid-16 system. Reference: 1J375 Power Cable.)	100.00

NOTE: CL-3 (Swintek) wireless systems are available with "blank" VHF channels, in accordance with recent FCC rulings.

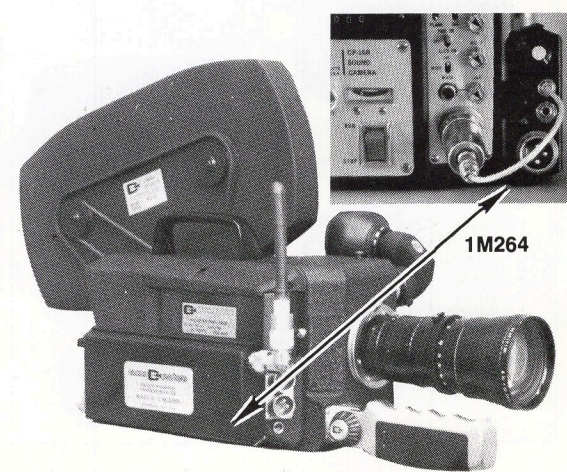

1G172

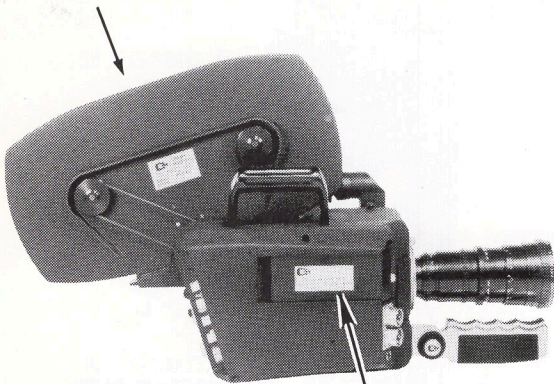

1K152

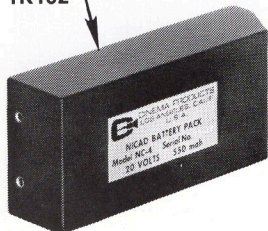

1K161



1K164

1K171



1K169



1J152

1G172

1G213

1G167

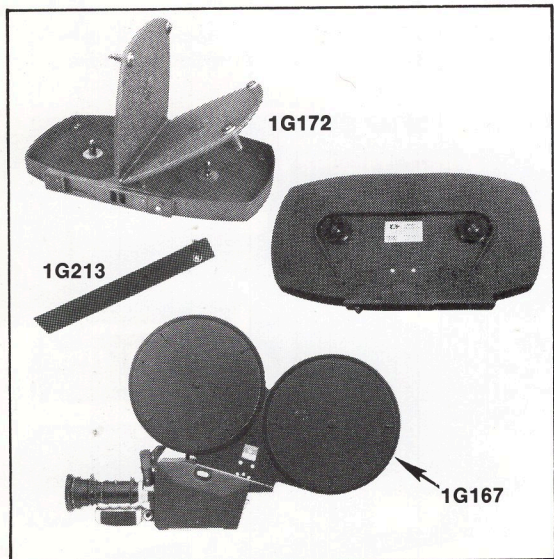

POWER SUPPLIES (FOR GSMO, CP-16 & CP-16R CAMERAS)

1K152	Battery Pack—Model NC-4	\$150.00
1K161	Battery Charger—Model NCC-6 (for use with NC-4 Battery Pack). Features charging status indicator light and current regulation. Input voltage switchable from 95-130 VAC range to 190-260 VAC range (60 or 50 Hz, single-phase supply).	65.00
1K164	Multiple Battery Charger—Model MBC-6 (1J152 cables additional).	400.00
1K169	AC Power Supply/Battery Charger, complete with one 1K171 AC/DC Power Adapter and one 1J152 Cable (for CP-16 and CP-16R only).	425.00
1K172	AC/DC Power Adapter (1K171) and Remote-Operation Battery-to-Camera Cable (1J154), for cold weather operation.	130.00
1K171	AC/DC Power Adapter "Dummy Battery" (as spare).	75.00

NOTE: Two NC-4 Nicad Battery Packs and two NCC-6 Battery Chargers are supplied as standard equipment with each CP-16 or CP-16R camera model, and with most GSMO packages. Please check listings.

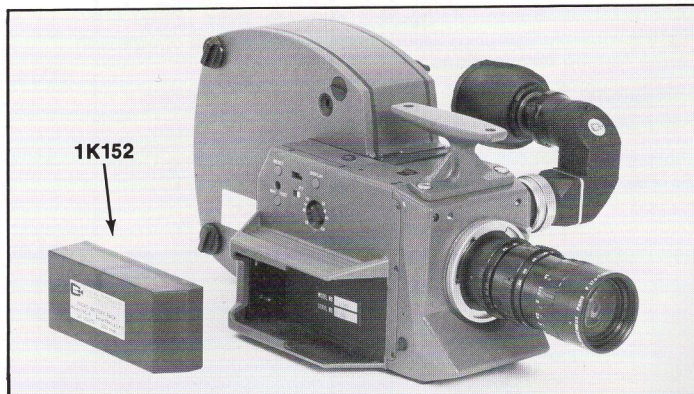

CABLES

1J187	Auxiliary Mixer (1M222)-to-Camera Cable, 10 ft.	250.00
1J192	Microphone-to-Camera Cable (3ft.), for top-mounted microphone.	45.00
1J195	Cable (5 ft.) — connects Crystalink transmitters to any microphone (includes 3-pin female connector and Vega jack).	55.00
1J196	Cable (5 ft.) — same as 1J195, but connects Crystalink transmitters to any microphone cable (includes 3-pin male connector and Vega jack).	55.00
1J160	Crystalink CL-3-to-Camera Cable (7"), as spare. (Does not include 1M269 Input Adapter.)	100.00
1J152	Battery Charger Cable (to charge 1K152 Battery Pack from 1K164 or 1K169).	45.00
1J154	Remote-Operation Battery-to-Camera Cable (2ft.), for cold weather operation.	75.00
1J211	CP-16R Sync Pulse Signal-to-Nagra 4 Recorder Cable (15 ft.).	80.00
1J301	GSMO Sync Pulse Signal-to-Nagra 4 Recorder Cable (15 ft.).	90.00

MAGAZINES AND ACCESSORIES (FOR CP-16 & CP-16R CAMERAS)

1G172	400 ft. (120m) Cinema Products Magazine—Model PLC-4A (including two 1G193 Core Adapters). New and improved ultra-lightweight PLC-4A Magazines are made of high-impact, glass-filled Lexan.® (Serial numbers above #10000 will accept a full 400' load of Fuji film.)	480.00
1G166	400 ft. (120m) Mitchell Magnesium Magazine.	480.00
1G167	1200 ft. (360m) Mitchell Magazine, includes 1G188 Belt.	1100.00
1G187	Take-up Belt, for 400 ft. (120m) Magazine (1G172, 1G166).	3.50
1G188	Take-up Belt, for 1200 ft. (360m) Magazine.	6.50
1G190	Lock Mount Stud, for PLC-4 type and Mitchell type Magazines, as spare.	2.80
1G213	Magazine Well Cover, Plate, for CP-16 type cameras, as spare.	25.00
1G193	Magazine Core Adapter, for PLC-4A/GSMO Magazines.	18.00
1G192	Magazine Core Adapter, for PLC-4 and Mitchell type Magazines.	18.00

MAGAZINES AND ACCESSORIES (FOR GSMO CAMERAS)

1G500	400 ft. (120m) GSMO Magazine—Model GC-4 (includes Film Gate Assembly).	\$ 2600.00
1G502	100 ft. (30m) GSMO Magazine—Model GC-1 (includes Film Gate Assembly).	2400.00
1L110	Film Gate Assembly, as spare.	800.00
1L301	GSMO Magazine Nose Cover.	12.00
1L300	GSMO Camera Magazine-Opening Cover.	12.00
1G194	Magazine Core Adapter, for GSMO 100 ft. and 400 ft. Magazines (May also be used with PLC-4A magazines.)	22.00

MAGAZINE ACCESSORIES (MISCELLANEOUS)

1G160	Changing Bag, for 400 ft. (120m) Magazines.	40.00
1G240	Film Shield Pro Pouch, protects film from airport X-Ray security devices. Measures 16" x 20" (41cm x 51cm). Can hold six 16mm 400' (120m) rolls, or two 16mm 1200' (360m) rolls, or one 35mm 1000' (300m) roll of film.	18.00

CAMERA ACCESSORIES

1L262	Lens Mount Cap (for CP-16R Reflex only).	22.00
1L117	Gelatin Filter Holder (CP-16 only).	2.00
1L118	Set of 6 CP-16 Gel Filter Holders (1L117)—supplied in case.	20.00
1L267	Gelatin Filter Holder (for CP-16R Reflex only).	3.80
1L268	Set of 6 CP-16R Gel Filter Holders (1L267)—supplied in case.	26.00
1L185	Accessory Bracket, swing-away type, for installation of mike and light (supplied with removable $\frac{3}{8}$ " and $\frac{1}{2}$ " studs).	120.00
1L201	24 fps Timing Pulley (black), as additional interchangeable pulley.	80.00
1L203	25 fps Timing Pulley (red), as additional interchangeable pulley.	80.00
1L255	Rain Cover—for CP-16R or CP-16R/A Reflex equipped with PLC-4 or Mitchell-type 400 ft. magazine. Permits easy access to all operating controls. Lens markings visible. Made of sturdy blue-colored Naugahyde.	85.00
1L134	Rain Cover, same as above, but for CP-16 and CP-16/A.	77.00
1L200	GSMO Road Cover, protects camera body from rain and environmental damage.	120.00
1L196	Carrying Grip, for CP-16 or CP-16R. Knurled grip (1" diameter). Replaces existing top carrying handle.	50.00
1L150	CP Tool Kit—To perform minor field repairs on CP equipment. Includes handle, handle extension, Xcelite interchangeable driver blades and bristol wrenches, screw starter and tweezers; (supplied in a compact plastic case).	22.00
1J156	On/Off Remote Cable (3 ft.), as spare.	50.00
1L386	CP-16R Sound Barney.	325.00

ZOOM LENSES—FOR GSMO & CP-16R REFLEX CAMERAS

1N319	Angenieux 10-150mm T2.3 BCP (supplied with T-stop markings only).	5250.00
1N312	Angenieux 12-120mm T2.3 BCP.	4085.00
1N370	Canon Macrozoom 12-120mm T2.7 CP.	3400.00
1N317	Angenieux 9.5-57mm T1.9 BCP.	5010.00
1N321	Angenieux 17.5-70mm T2.5 BCP (includes retro-zoom attachment for converting lens to T2.5 12.5-50mm).	1900.00
1N332	Angenieux 16-44mm T1.3 BCP.	6645.00
1N328	Angenieux 12-240mm T4.2 BCP.	11,425.00

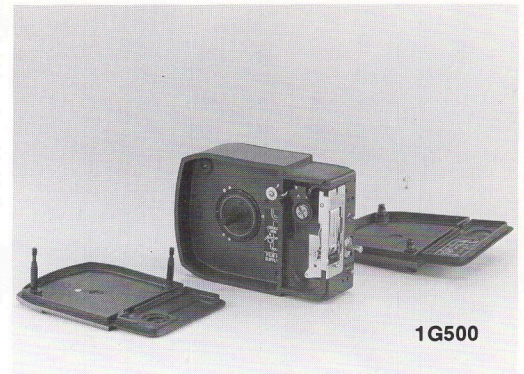

1G500

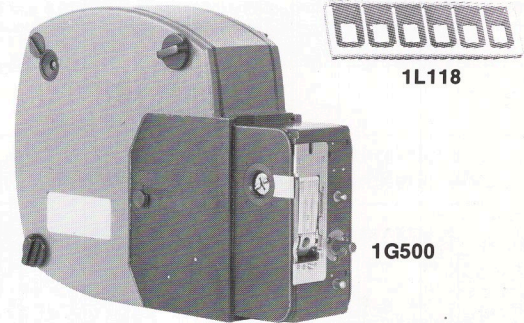

1L118

1G500

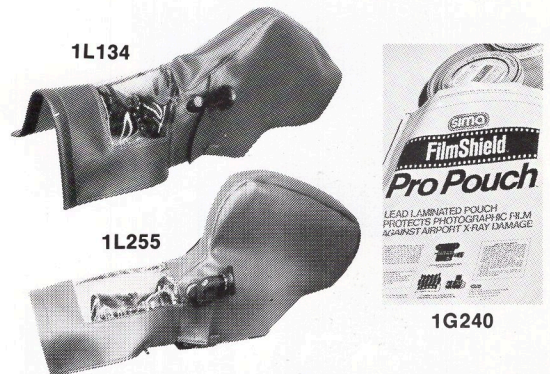

1L134

1L255

1G240

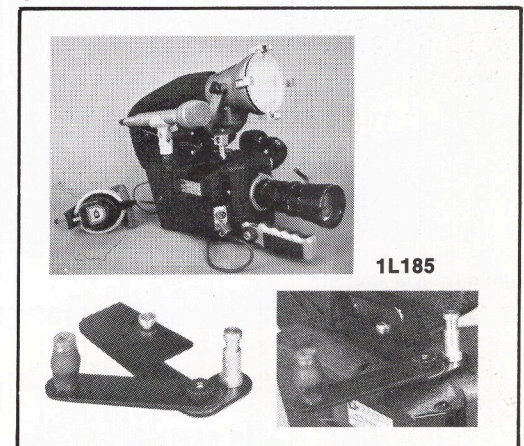

1L185

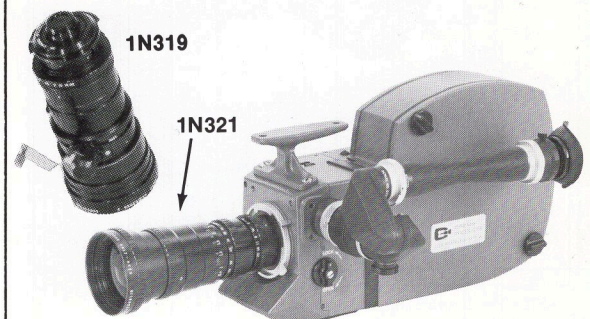

1N319

1N321

ULTRA

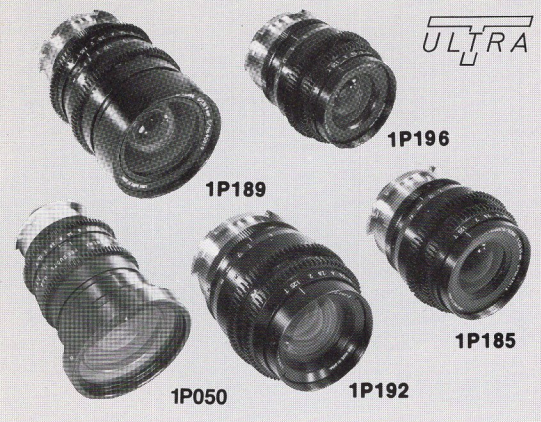

NOTE: Ultra T lenses are supplied with integral focus and iris gears, and flange depth shims. CP mounts may be interchangeable with Arri B and S mounts, and Eclair CA-1 mounts. Footage scales may be interchangeable with optional metric scales.

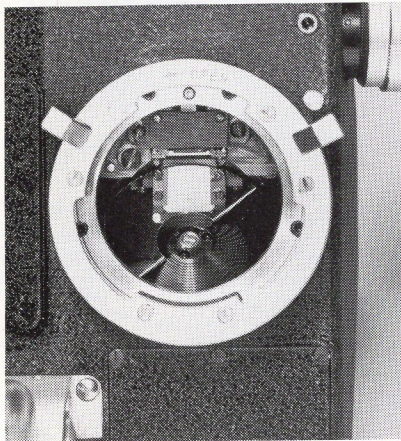
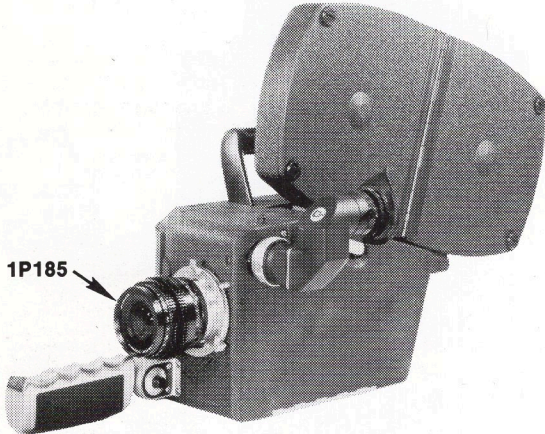

CP-16R shown with 170° high-efficiency spinning mirror shutter.

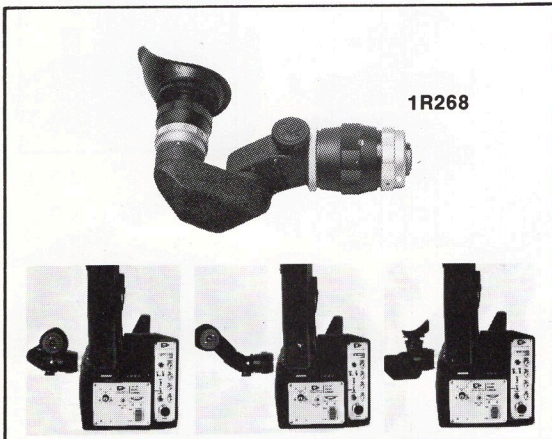

NOTE: For information concerning other adapters/modifications or conversions for existing lenses to CP reflex mount, please inquire.

PRIME LENSES—FOR REFLEX CAMERAS

1P155	Angenieux 5.9mm T2 CP.	\$ 2025.00
1P050	Ultra T 6mm lens, T 1.6, CP.	1800.00
1P189	Ultra T 9mm T1.35 CP.	1650.00
1P192	Ultra T 12.5mm T1.25 CP.	1435.00
1P196	Ultra T 16mm T1.25 CP.	1300.00
1P185	Ultra T 25mm T1.25 CP.	1180.00
1P055	Ultra T 6mm lens, T 1.6, Arri B.	1800.00
1P190	Ultra T 9mm T1.35 Arri B.	1700.00
1P193	Ultra T 12.5mm T1.25 Arri B.	1485.00
1P197	Ultra T 16mm T1.25 Arri B.	1350.00
1P186	Ultra T 25mm T1.25 Arri B.	1230.00
1P052	Ultra T 6mm lens, T 1.6, CA-1	1800.00
1P200	Ultra T 9mm T1.35 CA-1.	1700.00
1P201	Ultra T 12.5mm T1.25 CA-1.	1485.00
1P202	Ultra T 16mm T1.25 CA-1.	1350.00
1P203	Ultra T 25mm T1.25 CA-1.	1230.00

LENS ACCESSORIES

1S284	Data Rings, set of 4, for 10-150mm BCP Angenieux Zoom Lens.	50.00
1S282	Data Rings, set of 4, for 12-120mm BCP Angenieux Zoom Lens.	90.00
1S262	CP Reflex Lens Mount Adapter (Arri <i>standard</i> mount-to-CP-16R reflex mount).	100.00
1S263	CP Reflex Lens Mount Adapter (Arri <i>bayonet</i> mount-to-CP-16R reflex mount).	130.00
1S277	CP Reflex Lens Mount Adapter (Nikon-mounted lenses-to-CP-16R reflex camera. Installs in CP-16R lens port.)	275.00
1S210	CP GSMO Reflex Lens Mount Adapter (Nikon-mounted lenses-to-GSMO camera. Installs in lens port.	140.00
1S200	CP-to-C-mount Adapter.	300.00
1S274	CP Reflex Lens Mount Adapter. Adapts most Cooke Kinetal prime lenses already in Arri standard mount-to-CP-16R reflex camera. (For installation by factory or dealer only. Price does not include installation labor.)	150.00
1S290	Rear Lens Cap for CP Mount, as spare. (Large size, fits over CP mount.)	16.00
1P070	Arri Bayonet Mount, for Ultra T Lenses <i>only</i> .	160.00
1P080	CP Standard Mount, for Ultra T Lenses <i>only</i> .	130.00
1P090	Eclair CA-1 Mount, for Ultra T Lenses <i>only</i> .	160.00
1P679	Tiffen Filter Adapter (67mm 9), for Ultra T 9mm prime lens.	22.00
1P529	Tiffen Filter Adapter (52mm 9), for Ultra T 12.5mm, 16mm and 25mm prime lenses.	30.00
1S425	Tiffen 85 Series 9 Filter	35.00
1S400	Tiffen 85B Series 9 Filter.	45.00
1S426	Tiffen 85 N3 Series 9 Filter	45.00
1S427	Tiffen 85 N6 Series 9 Filter	45.00
1S428	Tiffen 81 EF Series 9 Filter	45.00
1S411	Tiffen Collapsible Wide Angle Rubber Sunshade, for Angenieux 9.5-57mm Lens (For use with 1S414 Tiffen Series 9 slip-on adapter.)	52.00
1S414	Tiffen Slip-on Series 9 Filter Adapter for Angenieux 9.5-57mm lens. (For use with 1S411 sunshade.)	40.00
1S412	Tiffen Collapsible Series 9 Rubber Sunshade. (Screw-in type, for 1S410 and other Tiffen adapters.)	30.00
1S413	Tiffen Collapsible 86mm Rubber Sunshade. Accepts Series 9 filters. (Screws into adapter supplied by Angenieux for 12-120mm and 10-150mm lens.)	30.00
1S404	Cine 60 Slip-on Lens Shade for Angenieux 12-120mm and 10-150mm lens. (Clamps over Angenieux Series 9 filter retainer supplied with lens.)	110.00

NOTE: Full range of additional lens accessories available (filters, sunshades, etc.). Please inquire.

VIEWING COMPONENTS

1R180	Rubber Eyecup for Cinema Products and Angenieux Viewfinders.	\$ 7.50
1R236	Fiber Optics Viewing Screen (focusing plate), for CP-16R Reflex camera as spare (with markings for 16mm projector aperture and TV safe action area, plus markings for 35mm 1.85:1 blow-up).	180.00
1R235	Same as above (1R236), but with 1.66:1 markings.	180.00
1R255	Screw-on Cap for Viewfinder Port, as spare.	6.00
1R256	Screw-on Cap for Viewfinders (either standard reflex or orientable), as spare.	6.00
1R500	Cinema Products Standard 12X Viewfinder (with positive lock), as spare.	1500.00
1R268	Cinema Products Orientable Viewfinder (erect image). Viewfinder pivots for left or right eye viewing, and offers full 360° erect image orientation. In normal operation, eyepiece is located 1" (25mm) behind film plane.	2375.00
1R271	Extension Tube Assembly—for convenient tripod operation when using the CP Orientable Viewfinder. In normal operation, eyepiece is located 7" (178mm) behind film plane. (For use only with CP Orientable Finder 1R268.)	600.00
1R504	Cinema Products GSMO Dual Purpose Viewfinder. Manually orientable for erect image viewing. Accommodates variances in eye/shoulder height. Permits GSMO camera to sit further back on shoulder. Extends to approximately 6" behind film plane (without requiring an extender).	1950.00

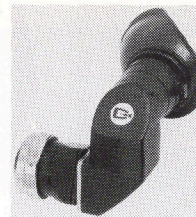

1R500



1R504

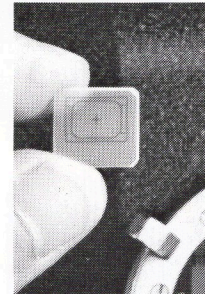

1R236



NOTE: Cinema Products and Angenieux Orientable Viewfinders are interchangeable.



GSMO shown with GSMO Dual Purpose Viewfinder.

J-5 HANDGRIP POWER ZOOM CONTROL

2G105	J-5 Handgrip Servo-Zoom Control & Motor (variable speeds to 2½ seconds max.). Includes Power Cable (2J119) & Motor Cable (2J218). Note: For use with GSMO add 1L009 Mounting Plate.	1725.00
2G146	J-5 Servo Motor, as spare (variable speeds to 2½ seconds max.)	750.00
2J218	J-5 Motor Cable, as spare (NOTE: Can also be used as a spare for CL-3 Cable 1J160).	100.00
2J219	J-5 Power Cable, as spare.	100.00
2J222	J-5 Remote Operation Cable Set (4½ ft.), includes 2J220 and 2J221 Power and Motor Cables.	240.00
2J220	J-5 Long Power Cable, for remote operation (4½ ft.), as spare.	125.00
2J221	J-5 Long Motor Cable, for remote operation (4½ ft.), as spare.	125.00

J-5 Bracketry (motor-to-lens)

2H133	J-5 Bracketry for Angenieux 10-150mm.	250.00
2H115	J-5 Bracketry for Angenieux 9.5-95mm or 12-120mm.	250.00
2H125	J-5 Bracketry for Angenieux 9.5-57mm.	250.00
2H145	J-5 Bracketry for Angenieux 12-240mm.	275.00
2H100	J-5 Bracketry for Angenieux 17.5-70mm.	220.00
2H220	J-5 Bracketry for Canon Macrozoom 12-120mm.	275.00

NOTE: Bracketry not included with 2G105 and 2G146. The same J-5 servo motor can be used with different lenses by ordering the appropriate bracketry.

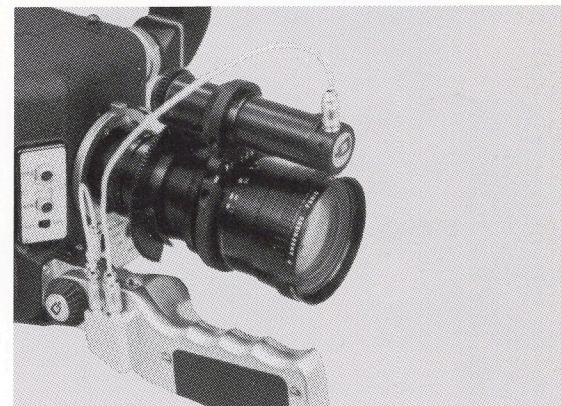

2G105 & 2H133

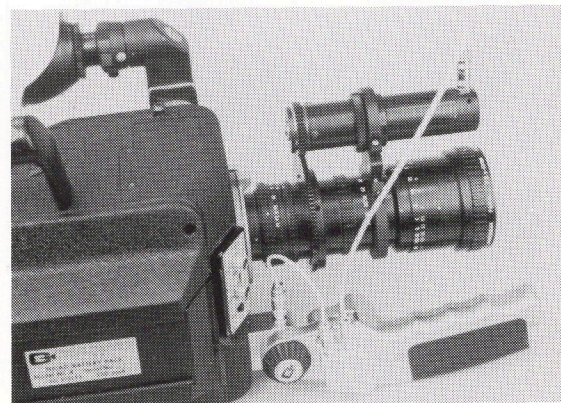

2G105 & 2H125

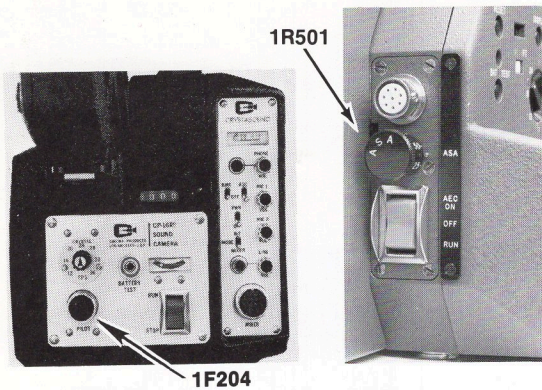

1R501

1F204

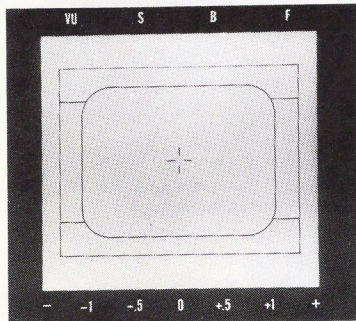
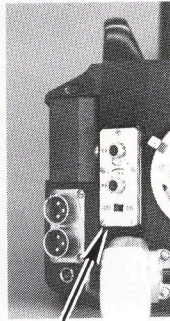
CP-16R
INFORMATION DISPLAY

1R284



1H500



1H057



1H132

EXPOSURE INFORMATION SYSTEM (FOR GSMO & CP-16R REFLEX CAMERAS)

- | | | |
|--------------|--|-------------------|
| 1R501 | Exposure Information (LED) Display for GSMO cameras. Features through-the-lens elliptical center-weighted silicon sensor (with emphasis in vertical direction). Exposure information appears on illuminated (LEDs) <i>display</i> in the viewfinder. ASA selector knob. Manual iris control. | \$ 1900.00 |
| 1R284 | Exposure Information (LED) Display for CP-16R and CP-16R/A cameras. Features through-the-lens elliptical center-weighted silicon sensor (with emphasis in vertical direction). Exposure information appears on illuminated (LEDs) <i>display</i> in the viewfinder. ASA selector knob. Manual iris control. | 2000.00 |

NOTE: Price of 1R501 and 1R284 does not include retrofit installation labor or update of early model cameras to LED information displays.

CAMERA MODIFICATIONS

- | | | |
|--------------|--|---------------|
| 1F204 | CRYSTASLATE—Auto-Slate Full Frame Marking Lamp/Bloop Tone Signal/Sync Pulse Output Signal (60 or 50 Hz Sine Wave). For use with Nagra 3 & 4, and similar tape recorders. Modification package for CP-16R <i>reflex cameras</i> . Does <i>not</i> include 1J211 or 1J213 cables. | 750.00 |
| 1F230 | 30 FPS Conversion Kit, converts CP-16R camera to 30 fps., crystal controlled for frame-to-frame transfer of film-to-video tape. Timing pulley installs in place of standard 24 or 25 fps pulley for operating speeds of 15;20;25;30 (crystal); 35;40 and 45 fps. | 125.00 |
| 1L012 | Mirror Open Modification Kit, allows shutter on older model GSMO cameras to be electronically commanded to stop in the <i>open</i> position with the aperture visible for inspection. | 165.00 |
| 1L013 | GSMO 30FPS Conversion Kit, converts camera to 30FPS, crystal controlled for frame-to-frame transfer of film to video tape. Provides operating speeds of 12, 20, 24, 25, 30, 48, and 64 FPS. | 165.00 |

NOTE: Retrofit installation of camera modifications may require additional labor charges.

GSMO CARRYING CASES

- | | | |
|--------------|---|---------------|
| 1H500 | GSMO Location Case, holds GSMO, one 400 ft. (120m) magazine—plus accessories. | 225.00 |
| 1H057 | GSMO Location Case, holds GSMO, three 400 ft. (120m) magazines—plus accessories. | 350.00 |

CP-16 & CP-16R CARRYING CASES

- | | | |
|--------------|---|---------------|
| 1H132 | CP-16R Travel Case, Extremely rugged <i>and</i> lightweight. Filled with rugged #4 foam padding, pre-cut to accept CP-16R reflex type camera, zoom lens, three 400 ft. (120m) magazines, two NC-4 battery packs, two NCC-6 chargers and other accessories. | 385.00 |
| 1H128 | CP-16 Location Case, with lock (for CP-16 reflex or non-reflex—plus accessories). | 350.00 |
| 1H162 | CP-16 Soft Location Case (for CP-16 reflex or non-reflex—plus accessories). | 180.00 |
| 1H187 | CP-16 Magazine Carrying Case, holds three 400 ft. (120m) PLC-4 or Mitchell-type magazines. | 150.00 |
| 1H191 | CP-16 Magazine Carrying Case, holds two 1200 ft. (360m) Mitchell-type magazines. | 240.00 |
| 1L205 | PLC-4A "Road Pouch." Environmental protection pouch for PLC-4 type magazines. | 72.00 |
| 1L210 | Zoom Lens "Road Pouch." Environmental protection pouch for popular 16mm zoom lenses. | 32.00 |
| 1L215 | Prime Lens "Road Pouch." Environmental protection pouch for popular 16mm prime lenses. | 30.00 |

SHOULDER PODS/SNAP-LATCH CAMERA MOUNTING SYSTEM

6S176	CP <i>Standard</i> Compact Shoulder Pod (screw-in type). For CP-16R.	\$ 105.00
6S180	CP <i>Snap-Latch</i> Compact Shoulder Pod (6S182), Camera Base Plate (1L242), and <i>Snap-Latch</i> Tripod Base Plate (6E123).	500.00
6S181	CP <i>Snap-Latch</i> Compact Shoulder Pod (6S182) and Camera Base Plate (1L242).	250.00
6E122	CP <i>Snap-Latch</i> Tripod Base Plate (6E123) and Camera Base Plate (1L242).	270.00
1L242	CP Camera Base Plate, as spare (for use with <i>Snap-Latch</i> Compact Shoulder Pod [6S182] or <i>Snap-Latch</i> Tripod Base Plate [6E123]).	40.00

GSMO HANDGRIPS

1L010	GSMO Handgrip Assembly; includes GSMO Handle Mounting Plate and CP-16R Handgrip.	425.00
1L009	GSMO Handle Mounting Plate, permits use of existing CP-16R Handgrip or J-5 (2G105). Note: Not for use with 1L007.	225.00
1L007	GSMO Quick Release Shoulder Pod & Handgrip.	650.00

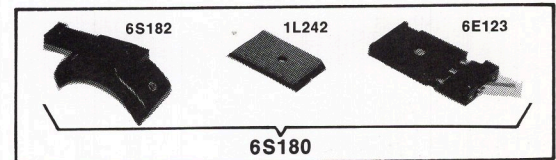
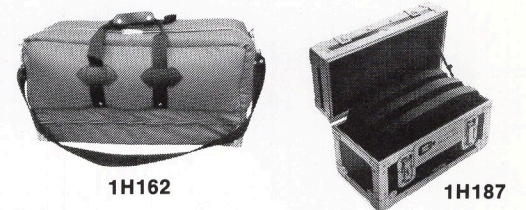
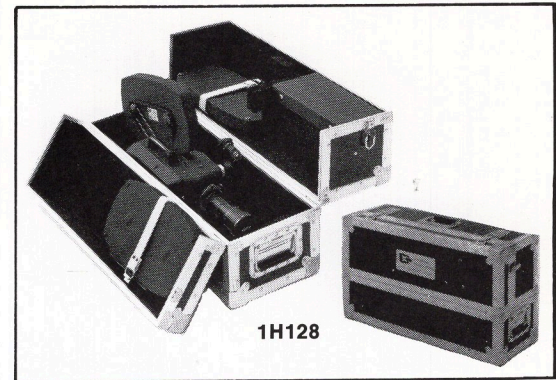
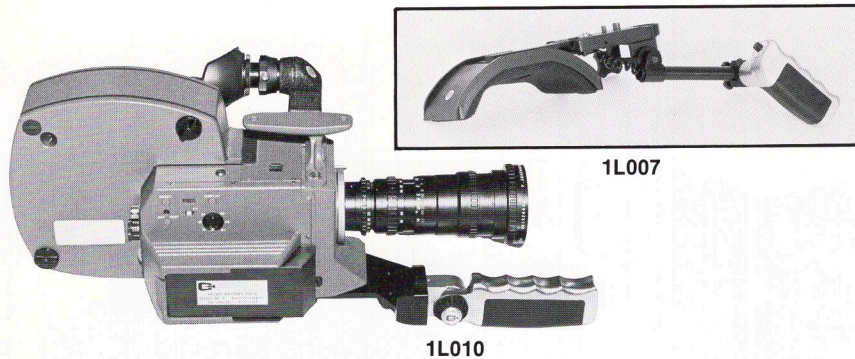

CINEVID-16 VIDEO-ASSIST CAMERA SYSTEM

The Cinevid-16 Video-Assist camera picks up the image directly from the fiber optics focusing plate and transmits it to any number of commercially available remote monitors. The image can also be recorded on a video tape recorder to provide "instant dailies."

1L350	Cinevid-16 Video-Assist Camera, for use with CP-16R Reflex. The Cinevid-16 attaches instantly to the CP-16R by means of a quick disconnect bayonet mount. Provides video image of 400 TV-lines (minimum). Adjustable iris is included in the relay optics to adjust for the ASA rating of the film being used. Removable coverplate for <i>field adjustment</i> (180° yoke rotation switch; 50/60 Hz output selector switch; field reversal switch; and individual horizontal and vertical picture size and position adjustments). Supplied with a video power supply unit permitting DC operation with a 12V battery or 120-240V operation from AC mains. The 1L350 consists of a Video-Assist Camera (with bayonet mount), Video Power Supply, Mounting Plate, and Video Adapter Unit (containing relay optics and bayonet mount). Price includes factory installation of Video Adapter Unit (containing relay optics and bayonet locking device) to CP-16R Reflex cameras equipped with the standard information display. (Additional cost to <i>retrofit</i> older CP-16R Reflex models <i>not equipped</i> with the information display. Please inquire.)	5750.00
1L355	Cinevid-16 Video-Assist Camera, for use with CP-16R Reflex and Steadicam (only). Same as 1L350 above, but does not include video power supply (1L356) and 12V power cable (1J375).	5500.00
1L357	Cinevid-16 Video-Assist Camera, with side mount adapter. Attaches instantly to the viewing port on CP-16R, NPR, GSMO, and similar 16mm cameras (in place of existing viewfinder).	6500.00
1L011	Cinevid-16 Video-Assist Camera, for use with GSMO. Includes: Video-Assist Camera (with same features listed in 1L350); Optical Viewfinder Assembly; Video Power Supply. Mounts directly to the viewing port. Permits both video and optical viewing.	6600.00

NOTE: A full range of accessory equipment for use with the Cinevid-16 system is available from Cinema Products. Please inquire.

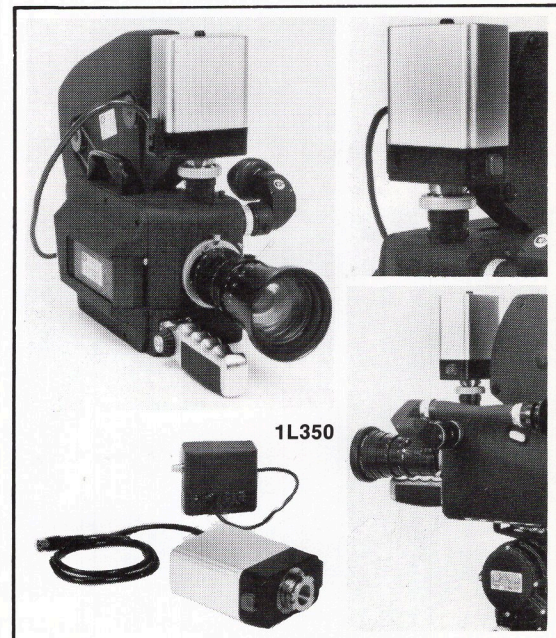

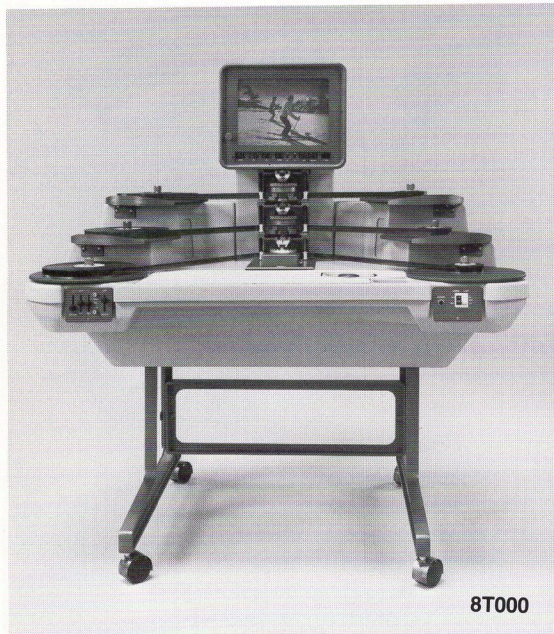
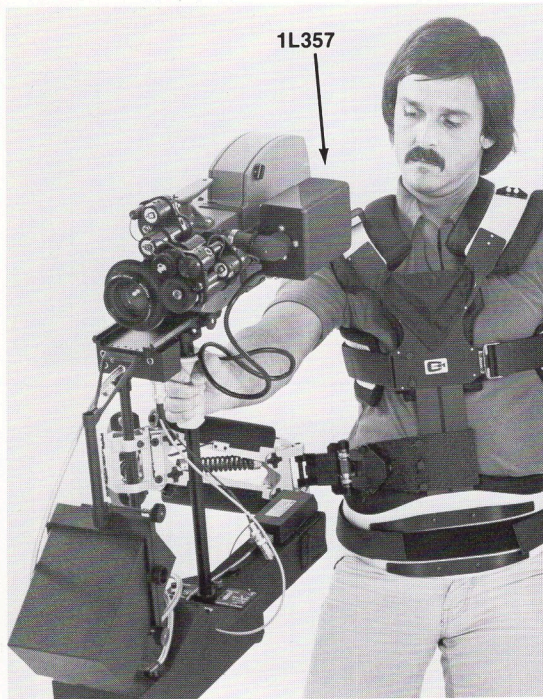

8T000

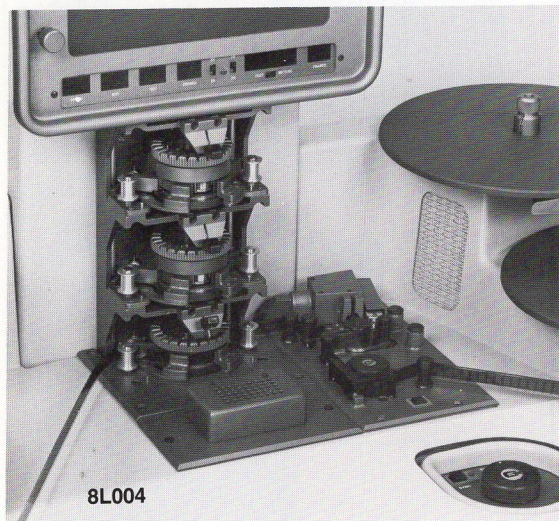

8L004

Cinevid Options & Accessories

1L365	Crystal Controlled Video Sync Generator, supplied with 1L236 Dovetail Mount and 1J379 Video Sync Cable.	\$ 600.00
1J379	Video Sync Generator Cable, 9" length (for 1L365), as spare.	50.00
1L356	Video Power Supply, for Cinevid-16, as spare. Does not include 12V power cable (1J375).	400.00
1J375	Cinevid-16 12V Power Cable (1 ft.), allows Cinevid-16 Video Power Supply to draw power from camera battery through <i>modified</i> Auxiliary Side Cover or <i>modified</i> Crystasound Amplifier. (Note: early model Crystasound Amplifiers also require 1M269 Input Adapter.)	60.00
1L397	Mounting Plate, as spare. Also allows mounting of existing Cinevid-16 Video Power Supply to Auxiliary Side Cover while drawing power from AC mains.	20.00
1L395	Dovetail (for Cinevid-16 Video Power Supply <i>only</i>), as spare.	50.00
1M269	Input Adapter.	100.00
1L359	Cap, for bayonet mount on Cinevid-16 Video-Assist Camera (1L350 and 1L355).	80.00
1R274	ACL Viewfinder Adapter, replaces existing viewing port, permitting use of Cinevid-16 (1L357) or CP Orientable Viewfinder (1R268) with ACL cameras.	225.00
1J240	Coaxial Cable, 30 ft. length, with terminations to power supply unit and monitor.	40.00

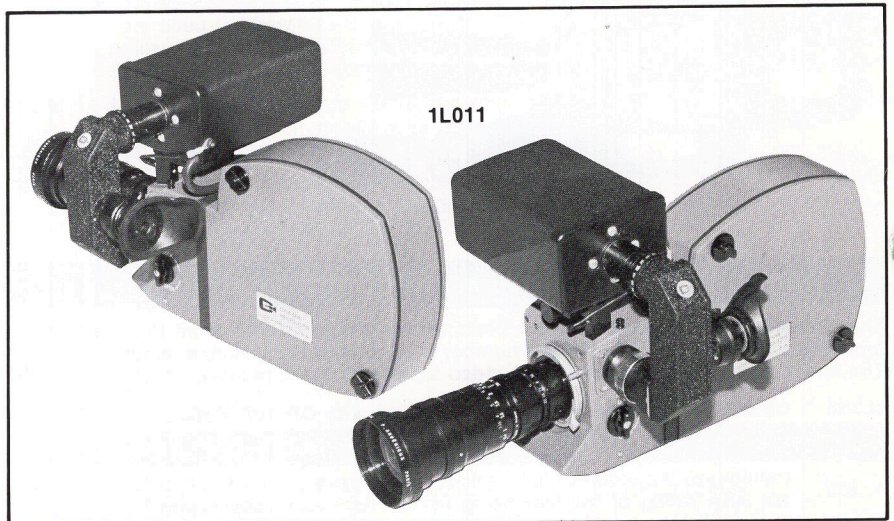

U/F-16 UPRIGHT FLATBED EDITING CONSOLE SYSTEMS

8T000	U/F-16 Upright Flatbed Editing Console. Three sets of terraced feed and take-up platters and three vertically mounted sprocket wheel assemblies. Display head tower features hollow polygon system, rear projection viewing screen, digital LED display for elapsed time and distance; memory in digital display. Film format and 'fps' switches. Film sprockets and supply and take-up platters controlled by single drive motor; speed controlled by electronic servo system. Crystal controlled 24/25 fps sync sound with variable speed control from 0.5 to 192 fps forward and reverse; push button on/off in sync mode. Slide attenuators for each soundtrack and master gain; rotating switches for high/low equalization. Console equipped with removable legs with casters. Unit supplied with Operation and Maintenance Manual, power cable, adjustment wrenches, etc.	9500.00
8T001	U/F-16 Upright Flatbed Editing Console with Optical/Magnetic Composite Sound Module (when installed at time of purchase).	11,500.00
8T003	U/F-S16 Upright Flatbed 16mm/Super 16 Editing Console.	9,800.00

ACCESSORIES FOR U/F-16

- | | | |
|--------------|---|-------------------|
| 8L004 | Optical/Magnetic Composite Sound Module. Reads magnetic or optical sound tracks from picture film. Unit mounts on editing console table top. Onboard optical and magnetic audio preamps. Includes exciter lamp and regulator. Sound frequency response: $\pm 2\text{dB}/100\text{Hz}$ to 6kHz for Optical Mode; $\pm 2\text{dB}/50\text{Hz}$ to 8kHz for Magnetic Mode. RMS wow and flutter spec of .5%. Capable of high speed through the sprockets; flywheel automatically disengages when not running sync. More gain control built into audio control panel. | \$ 2400.00 |
| 8L001 | Compliance Arm Assembly Set. Supplemental sound film tension roller and guide roller assembly to install on right and left of stock sprocket assembly. For one or both sound film transports. Isolates platter rates; improves wow and flutter performance. | 400.00 |
| 8L005 | Wide Angle Viewing Screen. Wide view, non-center weighted screen for editor-and-client viewing. (As a replacement for standard viewing screen.) | 50.00 |
| 8L006 | Reel Adapter. Enables table to accept film reels in place of cores on picture track. Easily installed on platter drive spindles. (ea.) | 30.00 |
| 8L002 | Leatherette Cover. Contoured, durable brown leatherette dust cover. Fits over tower, table top and extends over edges. | 115.00 |



8L002

Prices & Specifications Subject to Change Without Notice.
Prices F.O.B. Factory (Los Angeles, California).

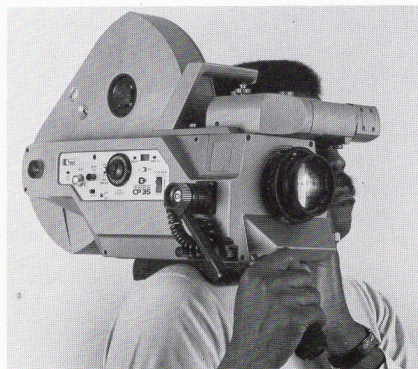
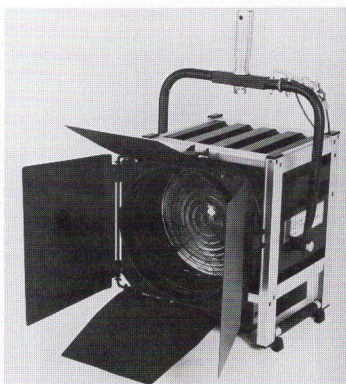
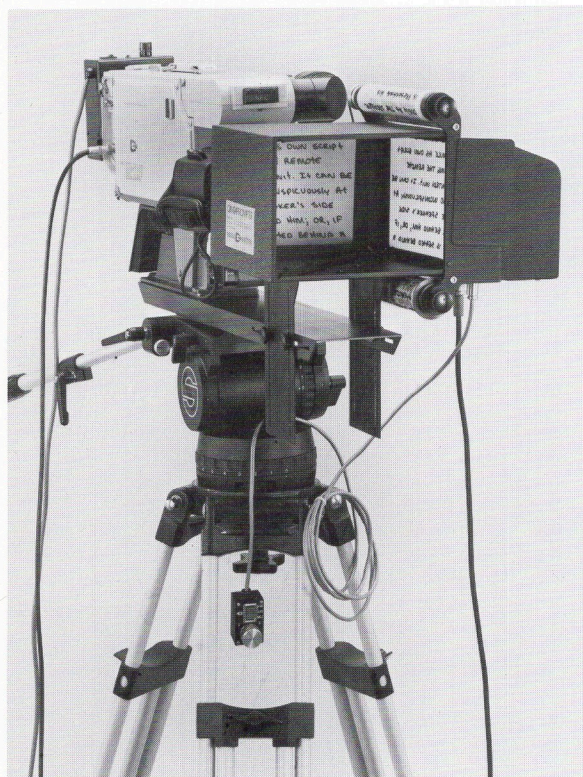

IMPORTANT

Please check our separate price lists for information on Cinema Products' line of location/studio lighting, tripod heads and accessories, Camaprompter portable prompting system, professional broadcast video equipment, 35mm camera systems, the Oscar-winning Steadicam camera stabilizing system, etc.

Price List

EFFECTIVE DATE:
APRIL 1, 1984

GSMO & CP-16 16mm Camera Systems

and U/F-16
Upright Flatbed
Editing Consoles

For Newfilm,
Documentaries,
Television Commercials,
Studio Feature Production.

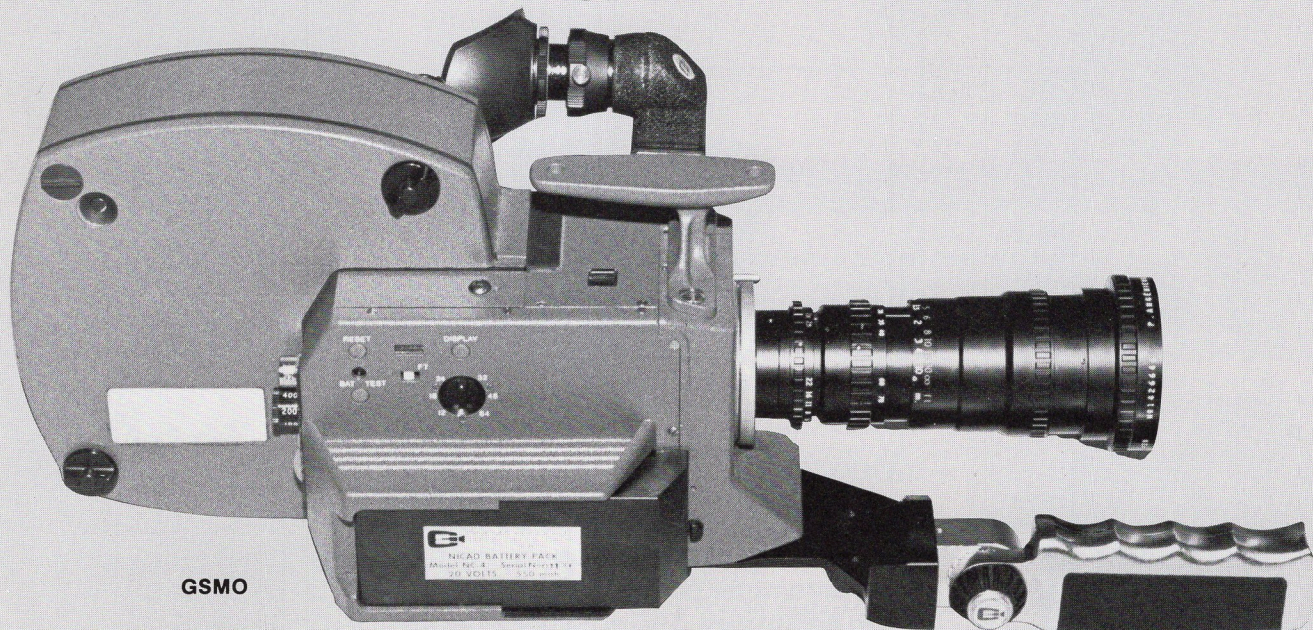

GSMO

cinema  products
CORPORATION
Technology In The Service Of Creativity