

Everyone's Own Favourite



Landscapes, portraits, close-ups, action shots, copying — right down to underwater photography: your Rollei will cope with them all. The basic camera has already given you many outstanding pictures.

But if you want to go further and get still better results, you need some of the versatile Rollei accessories.

Your photo dealer has them all ready for you — from the lens hood to the Rolleimarin underwater housing.

For perfect projection use the Rollei Universal projector. And as a handy second camera we recommend the automatic Rollei 16.

All optical attachments — like the Rollei lenses themselves — have an abrasion-resistant anti-reflection coating. So you are sure of the utmost image brilliance even when using these lens accessories. The individual coating of Rollei filters to match the filter colour at the same time ensures the maximum contrast.

Rollei lens attachments are available in the following bayonet mount sizes:

- 0 : for the Rollei 16
- I (4×4) : for the Rolleiflex 4×4
- I (6×6) : for 2¼×2¼ inch (6×6 cm.) Rollei cameras with Tessar, Xenar and Triotar lenses
- II : for the 2¼×2¼ inch (6×6 cm.) Rollei cameras with Planar and Xenotar f/3.5 lenses and for the Rollei-Magic
- III : for the 2¼×2¼ inch (6×6 cm.) Rolleiflex with Planar and Xenotar f/2.8 and Sonnar f/4 lenses
- IV : for the 2¼×2¼ inch (6×6 cm.) Rolleiflex with Distagon f/4 lens
- V : for the Rollei-Mutar 0.7 and 1.5 (screw mount)

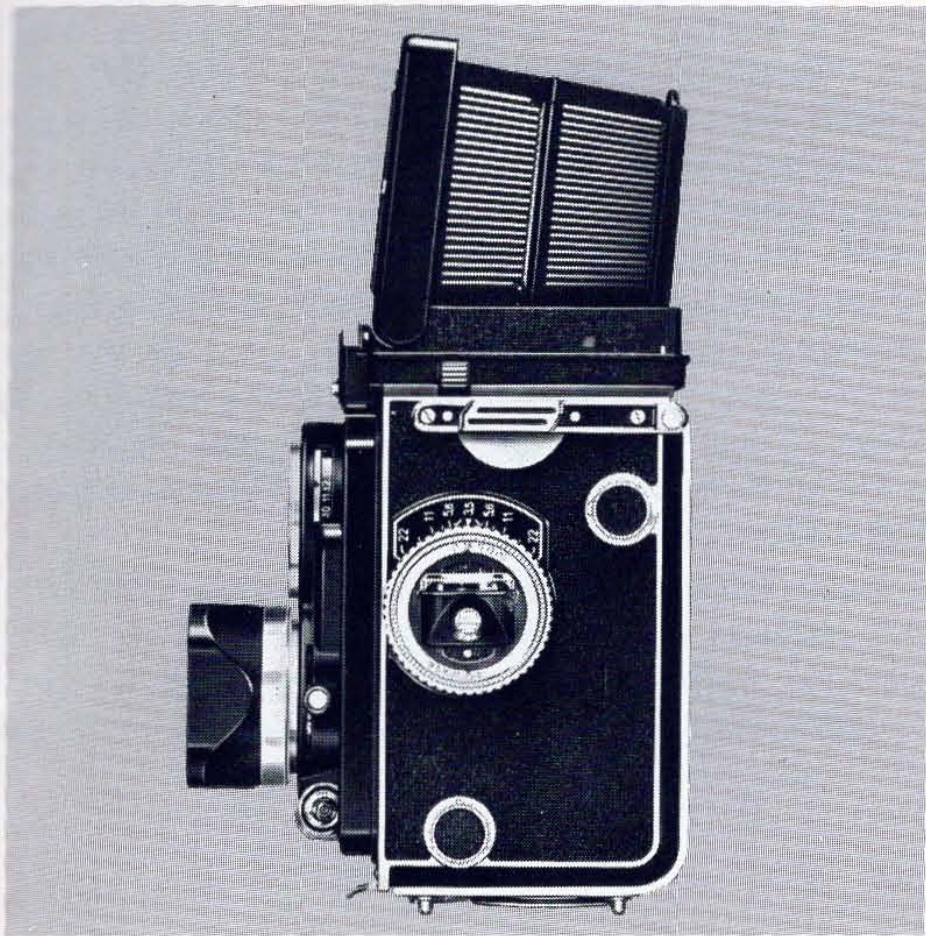

The Lens Hood

Use the lens hood when the lens is directly exposed to strong light sources or reflections (from the beach, water, snow or lamps in the picture) or to splashes from rain and water. To be on the safe side, use it all the time.

The Rolleilux Accessory Exposure Meter

Available in bayonet size I for Tessar, Xenar and Triotar lenses. The exposure meter can be aimed and can measure most precisely when it is firmly mounted on the camera, so that its field of view coincides with that of the camera. This is the case with the Rolleilux. The exposure meter is ingeniously built into the lens hood and swings out for use.

Being right next to the lens, it is conveniently in view all the time. While you sight the subject, you move the setting pointer to obtain the correct exposure value and aperture/shutter speed combination. With the diffusing screen you also take incident light readings. The measuring range of the Rolleilux covers exposure values from 2 to 18 with exposure times from 60 seconds to $\frac{1}{500}$ second and apertures from f/3.5 to f/22. A leather case, matching the camera case, carries the Rolleilux attached to the camera strap and always ready for use.

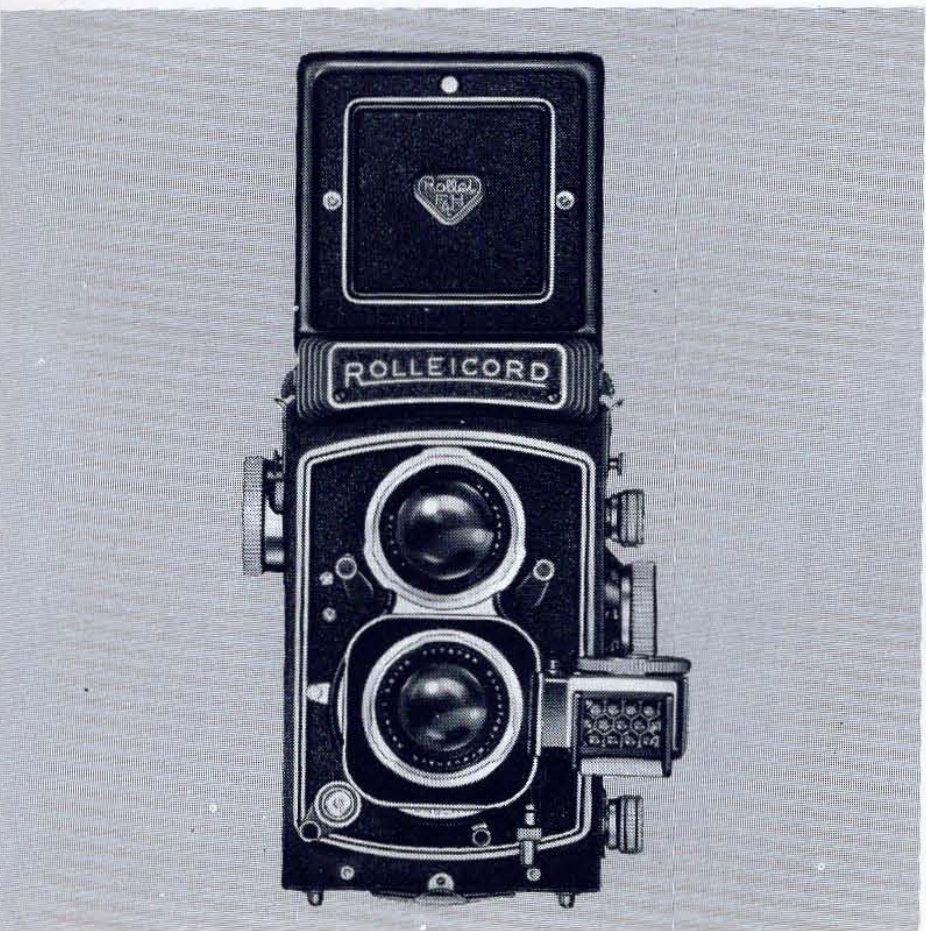

The Exposure Meter for Installation

This is available for the Rolleiflex T, the Rolleiflex models 2.8 E 2, 2.8 E 3, 3.5 E 3 and the Tele and Wide-angle Rolleiflex. The outfit consists of a replacement name plate with photo cell, the meter movement and an incident light diffusor. This is easy to install in the camera — you can do it yourself.

Lens Hood Rolleilux Exposure Meter for Installation

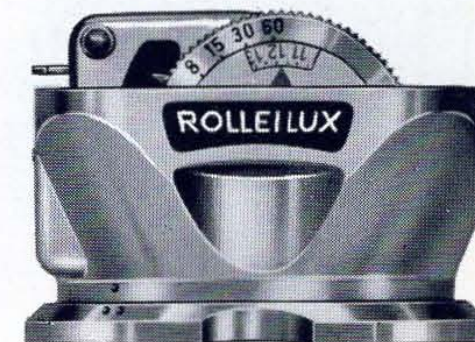
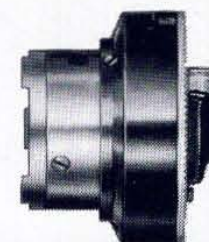

Filters for Colour Photography

Colour Compensating Filters

Colour rendering depends on the colour quality of the illumination. Colour compensating filters are useful to correct variations in the light colour, either to obtain the most natural colour balance, or to control the rendering at will.

There are two types of filters in this colour compensating range: the reddish R filters subdue excessive blueness, and the bluish B filters excessive redness. In daylight you are most frequently likely to need the R-1 and R-2 filters (with their "skylight" filter effect) to avoid blue casts. In tungsten lighting and with clear flash bulbs the B-11 filter ensures correct colour rendering even on daylight type colour film.

The filters are available singly or as a set in a leather case.

The H-1 Filter

This colourless ultra-violet absorbing filter for daylight type colour film reduces the tendency to excessive blueness in distant views. It is recommended for general use in colour photography. If you keep it constantly in front of the lens, the filter also protects the lens itself. It needs no increase in exposure time.

The H-1 filter is intended for Xenar and Tessar lenses. The Planar, Xenotar, Sonnar and Distagon lenses already provide the ultra-violet absorption of this filter.

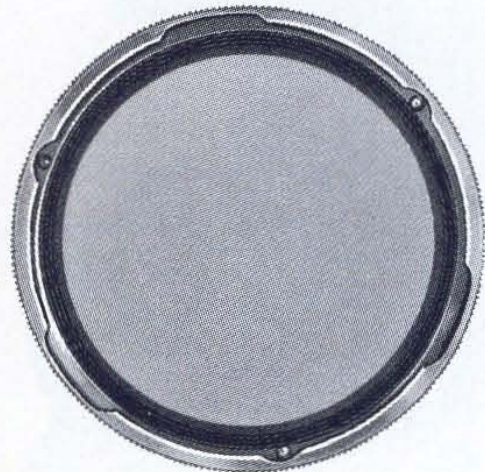

Filters for Black-and-White Photography

Rollei filters add atmosphere to your pictures: the light and medium yellow filters enhance clouds and delicate snow shadows, the light green and green filters improve the tonal separation of green foliage. The orange filters — and even more the light red filter — bring out detail and contrast beyond that visible by the eye. Clouds are dramatically emphasised, while natural green foliage appears lighter. The pale blue filter emphasises misty effects and darkens red tones in artificial light exposures.

Often filters are also necessary to separate colours of similar luminosity by increasing the contrast between their grey values. The film then records the filtered colours with greater clarity and detail.



Other special filters for black-and-white work: The ultra-violet absorbing filter reduces the veiling effect of ultra-violet radiation in high mountains about 6,000 feet and at the seaside — but also in intense sunlight in tropical latitudes. This filter is not needed if you are already using one of the above listed filters.

The infra-red filter is specially intended for infra-red film and transmits deep red light beyond 700 $m\mu$ and infra-red rays. With built-in focusing compensation, this filter is useful for moonlight effects, haze and mist penetration and many scientific applications.

The neutral density filters Nos. 2 and 4 permit the use of lower exposure value settings (giving a greater range of aperture-speed combinations) with ultra-speed films. Also suitable for colour films.

The required exposure value correction (filter factor) is engraved on the mount of each filter.



The Rolleisoft Soft Focus Attachment

The Rolleisoft tones down the pin sharpness of the Rollei picture to a softness of definition — not to be confused with unsharpness — which is specially suitable for female portraits. This results in a softer skin rendering and optically suppresses disturbing wrinkles — without needing further retouching. The pinsharp lens now acts like a soft-focus lens.

You can judge the effect yourself on the focusing screen. The softening is strongest when shooting into the light: the Rolleisoft gives extra luminosity to brilliant lighting rims and spreads the highlights to create a "dreamy" atmosphere.

The Rolleisoft is available in two powers — 0 and 1 — and is placed in front of the lens like a filter. It needs no adjustment of the exposure setting.

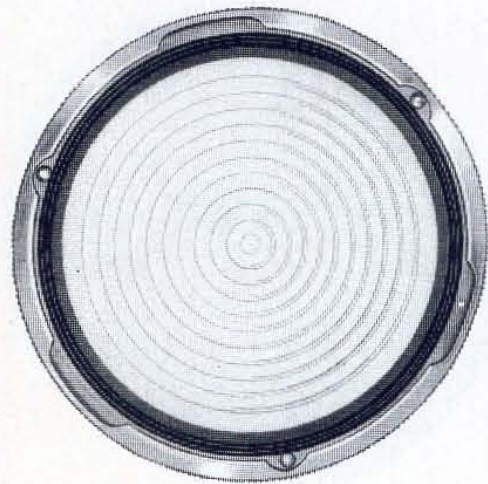

The Rolleipol Polarising Screen

The polarising filter works miracles: a slight turn of the filter in front of the lens extinguishes reflections on non-metallic shiny surfaces. Reflecting glass panels and spectacles really look transparent. The surface detail of polished objects — other than metals — becomes clearly visible and you can even look through a reflecting water surface.

In landscape pictures on colour film the polarising filter modifies the colour rendering. It darkens the blue sky and increases the saturation of the other colours.

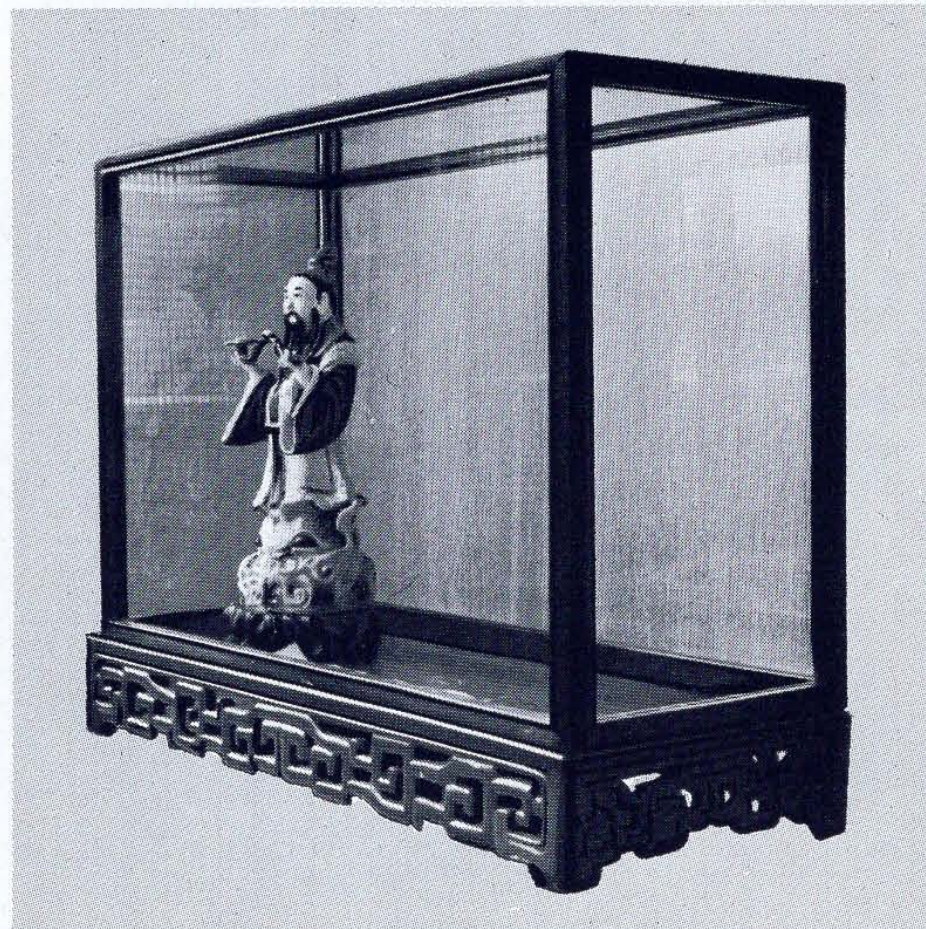
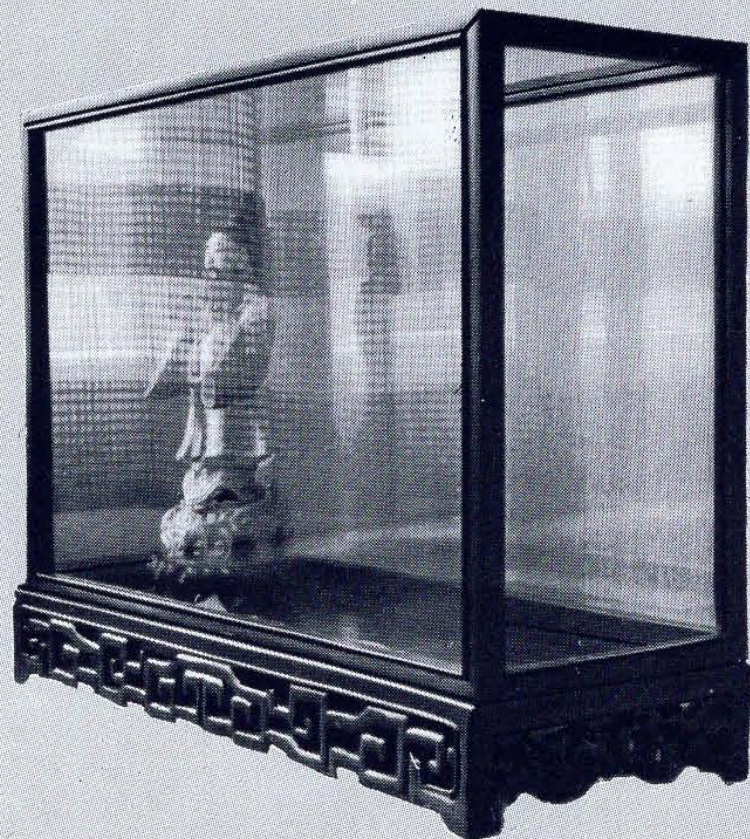

Supplementary Lenses for Close-ups and Copying

With the Rolleinar lenses you can set out to explore a new world of near subjects. These close-up lenses are mounted in pairs in front of the camera lenses.

Now you can go below the normal near focusing limit and with an appropriate Rolleinar set approach the subject to within $17\frac{1}{2}$, $12\frac{1}{2}$ or $9\frac{1}{2}$ inches (45, 32 or 24 cm.). This type of close-up photography needs no exposure increase and you watch the picture in the usual way on the focusing screen.

The Rolleinar lenses for the finder lens provide the necessary parallax compensation. At these reduced subject distances you can achieve a scale reproduction of up to $\frac{1}{3}$ natural size. So a 3-diameter enlargement of a negative is sufficient to yield a same-size macro picture.

The Rolleinar lenses are available in three sets of matched pairs:

Rolleinar 1 for distances from $39\frac{1}{2}$ to $17\frac{1}{2}$ inches (100 to 45 cm.);

Rolleinar 2 for distances from $19\frac{3}{4}$ to $12\frac{1}{4}$ inches (50 to 31 cm.);

Rolleinar 3 for distances from $12\frac{1}{2}$ to $9\frac{1}{2}$ inches (32 to 24 cm.).

The Tele-Rolleiflex has a different focusing range and two further Rolleinar sets are available for it:

Rolleinar 0.35 for distances from 9 to $4\frac{1}{2}$ feet (280 to 135 cm.);

Rolleinar 0.7 for distances from $4\frac{1}{2}$ to 3 feet (138 to 93 cm.).

Both these pairs of close-up lenses have a twin mount, the 0.35 set also an additional hinged fitting. With this you can instantly extend the focusing range of the Tele-Rolleiflex down to $4\frac{1}{2}$ feet (135 cm.). Both these special Rolleinar sets have a front bayonet mount and can be combined with the normal Rolleinar sets Nos 1, 2 and 3 to cover the same close-up range.

With the Wide-angle Rolleiflex you can focus down to 2 feet (60 cm.) without supplementary lenses. The Rolleinar set No. 2 (bayonet size IV) then extends the near focusing range down to $9\frac{1}{2}$ inches (24 cm.).

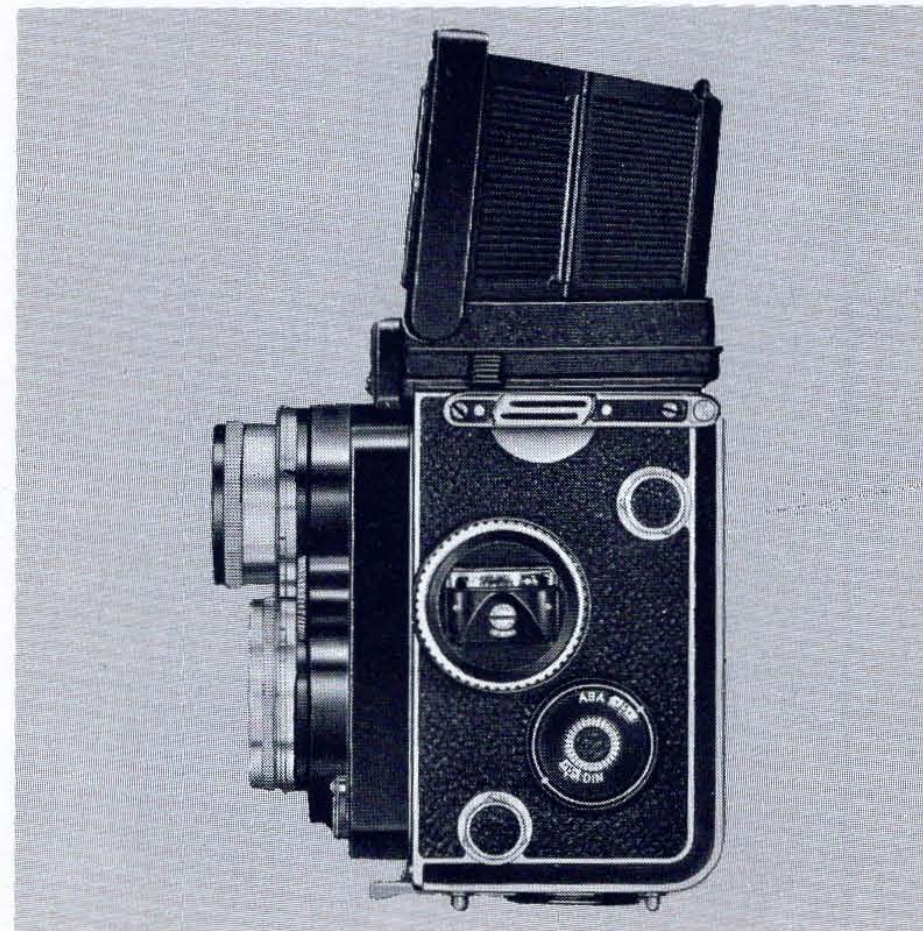



„Spotted Woodpecker”
Electronic flash with extension unit
Agfacolor CT 18, 1/125 sec. at f. 22
Rolleinar set No. 1, Remote release.

The Rolleiflash Flash Gun

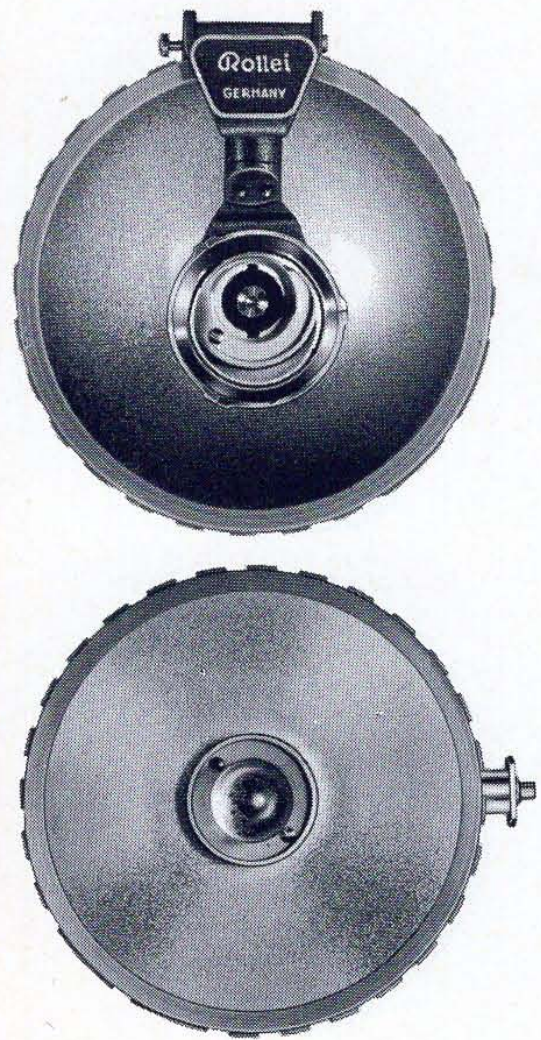

Whether you want to shoot nocturnal scenes or fill in shadows in daylight shots, the Rolleiflash 2 is the ideal flash gun for your Rollei. You can use flash bulbs of three different base fittings (including all-glass capless bulbs) and you can get the right type of bulb anywhere. The light is adjustable for wide-angle and concentrated beams — according to the distance of the subject and the picture format used. A rotating calculator shows the required aperture for any distance.

The Rolleiflash 2 has a bracket to fit on to the mount of the finder lens. This is available in bayonet sizes I, II, III and IV for the various Rollei models.

For the two Rollei-Magic cameras the flash gun is available in a special version: the Rolleiflash M has a foot with built-in-contact, used for mounting the gun on the side of the camera. Both versions of the Rolleiflash incorporate a test lamp, bulb ejector and open-flash switch.

For special lighting effects or for illuminating larger rooms you can connect one or two Rolleiflash Comb 2 extension units and so fire two to three flashes simultaneously. The Rolleiflash is the only gun for expendable bulbs with this facility.

Further accessories for the Rolleiflash 2 include a carrying case for one flash gun, a 10 foot (3 metre) flash cable, a 32 inch (80 cm.) cable, an extending coiled cable for 12 to 40 inches (30 to 100 cm.), and a connector for two cables.

To connect electronic flash units without the locking flash plug, flash cables of 32 inches (80 cm.) or 6½ feet (2 metres) length are available with a plug at one end only, and a free cable end for connection to the flash unit.

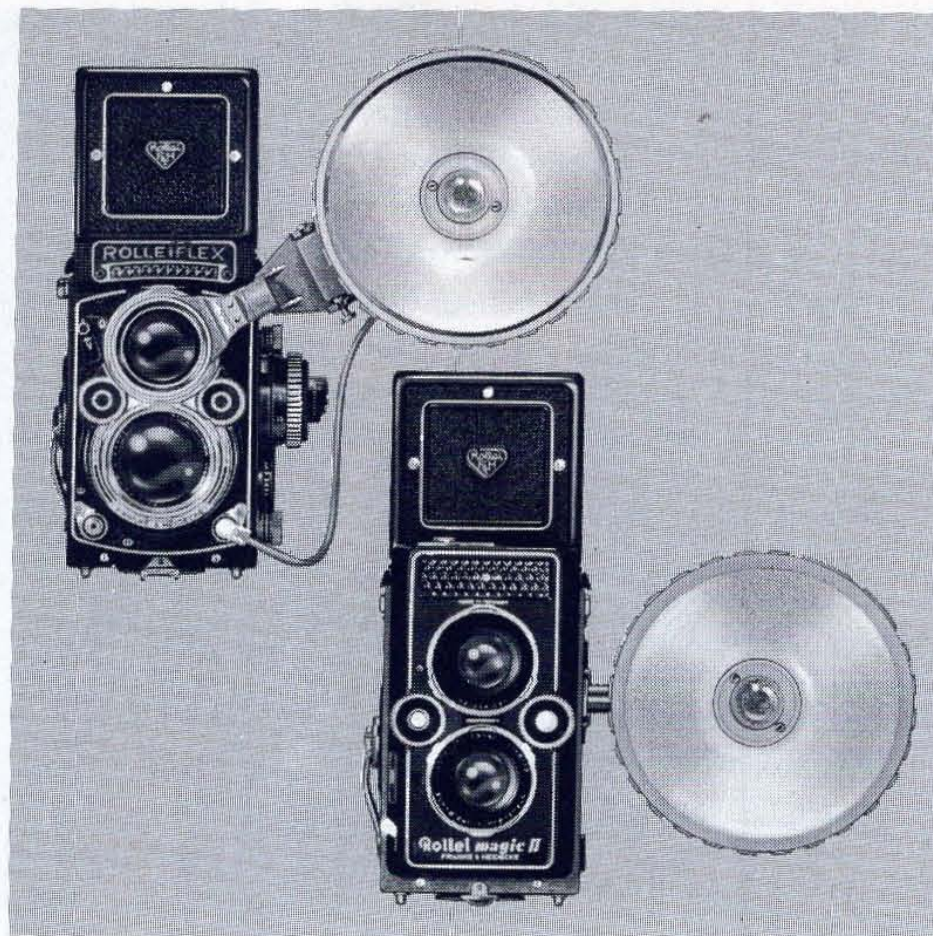

The Focusing Screen with Rangefinder Wedge

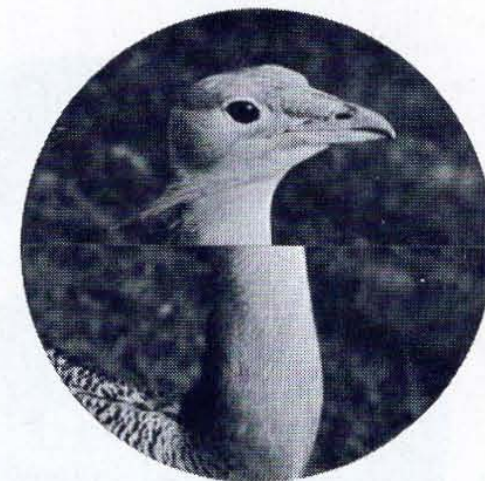

The optical wedges in the centre of the screen provide an additional focusing aid. They act as a split-image rangefinder; when the two halves of the image are lined up you are sure of pin-sharp definition.

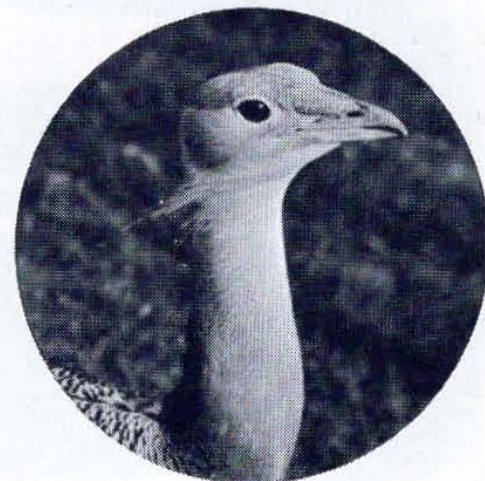

The clear area of the wedges shows the image in its full brightness — useful when working in poor light or with dark subjects. This screen can be installed in any 2¼ × 2¼ inch (6 × 6 cm.) Rollei.

Five Picture Sizes The Rolleikin

The universal $2\frac{1}{4} \times 2\frac{1}{4}$ inch (6×6 cm.) format is just one of the picture sizes of the Rollei. But the Rollei can also be adapted to special requirements, for example where the subject does not fill the picture field or where you want to cut down the image area for a telephoto effect, have a larger exposure reserve for shooting sessions without film changing, or for more economical use of the film. In every case you can convert the Rollei as required in a few simple steps.

With Roll Film

For $1\frac{5}{8} \times 2\frac{1}{8}$ inch (4×5.5 cm.), $1\frac{5}{8} \times 1\frac{5}{8}$ inch (4×4 cm.), 28×40 mm. and 24×36 mm. pictures:

You can mask down the $2\frac{1}{4} \times 2\frac{1}{4}$ inch (6×6 cm.) picture size to $1\frac{5}{8} \times 2\frac{1}{8}$ inches (4×5.5 cm.), covering at the same time the $1\frac{5}{8} \times 1\frac{5}{8}$ inch (4×4 cm.) format. You gain four extra exposures per roll. So the Rollei provides 16 instead of 12 shots which you can utilise either as a horizontal $1\frac{5}{8} \times 2\frac{1}{8}$ inch (4×5.5 cm.) picture or a $1\frac{5}{8} \times 1\frac{5}{8}$ inch (4×4 cm.) super slide transparency for most presentday miniature projectors.

For this you need a 16-exposure mask set for the Rolleiflex T, the Rollei-Magic, and the Rollei-Magic II; or the 16-exposure conversion outfit for the Rolleicord. The Rolleicord can also be converted with a 24-exposure outfit to a masked-down image size of 28×40 mm. (to include 24×36 mm.)

With 35 mm. Film (24×36 mm.)

The Rolleikin outfit converts the $2\frac{1}{4} \times 2\frac{1}{4}$ inch (6×6 cm.) Rollei to a 24×36 mm. miniature camera to take 20 or 36 exposure cassettes of 35 mm. film.

The Rolleikin is available for:

Rolleicord models with serial Nos. from 1,137,000; the Rolleiflex 3.5 with serial Nos. from 1,100,000; the Rolleiflex 2.8 with serial Nos. from 2,350,000; the Tele-Rolleiflex with serial Nos. from 2,305,001; the Wide-angle Rolleiflex with serial Nos. from 2,490,000.

For older Rolleis:

Rolleikin 1 (35 mm. adapter with special back) for $2\frac{1}{4} \times 2\frac{1}{4}$ inch (6×6 cm.) Rollei cameras with serial Nos. from 567,000 to 1,099,999 (Rolleiflex) and to 1,136,999 (Rolleicord).

Rolleikin 2.8 for the Rolleiflex 2.8 with serial Nos. up to 1,665,999 and Tele-Rolleiflex with serial Nos. up to 2,305,000.

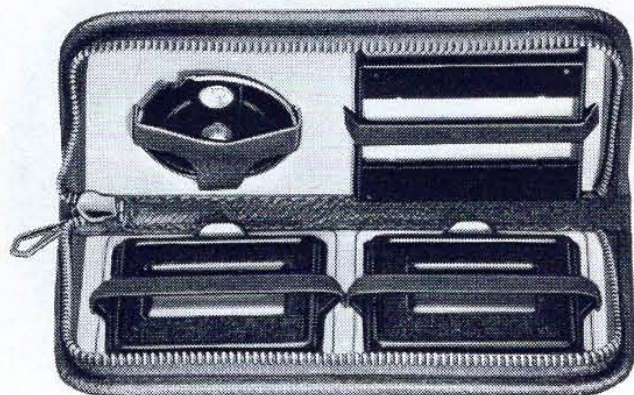

Rolleikin

Rollei-formats

1. 4×5,5 cm
2. 4×4 cm
3. 28×40 mm
4. 24×36 mm
5. 6×6 cm

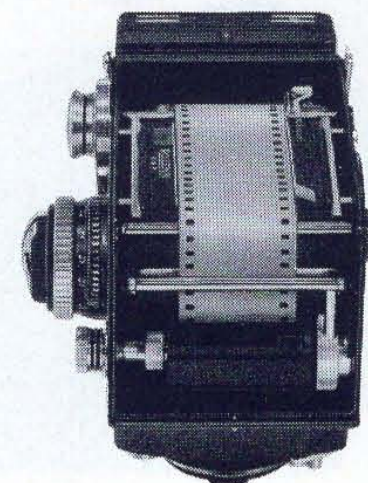

The Pentaprism

The pentaprism offers eye-level viewing combined with the usual positive focusing of the Rollei. The Rollei pentaprism is ideal in conjunction with the pistol grip for news, sports and flash photography as well as for portraits. The magnifying eyepiece shows the entire finder field upright and the right way round — in its full sharpness. The image moves in the same direction as the object and the rubber eyepiece shell screens off stray light. This eyepiece shell can also be folded back. With the camera turned upside down you can easily take overhead shots. The eyepiece lens is interchangeable to compensate for individual eyesight variations. For viewing without spectacles alternative eyepiece lenses are available in powers of 0 (normal), plus or minus 1, 2 and 3 dioptries, in accordance with the prescription for distant viewing glasses. The Penta B special eyepiece is a universal type with which you can see the full finder image even when wearing spectacles. The pentaprism fits every $2\frac{1}{4} \times 2\frac{1}{4}$ inch Rollei with removable folding hood. Older Rollei models can be converted.

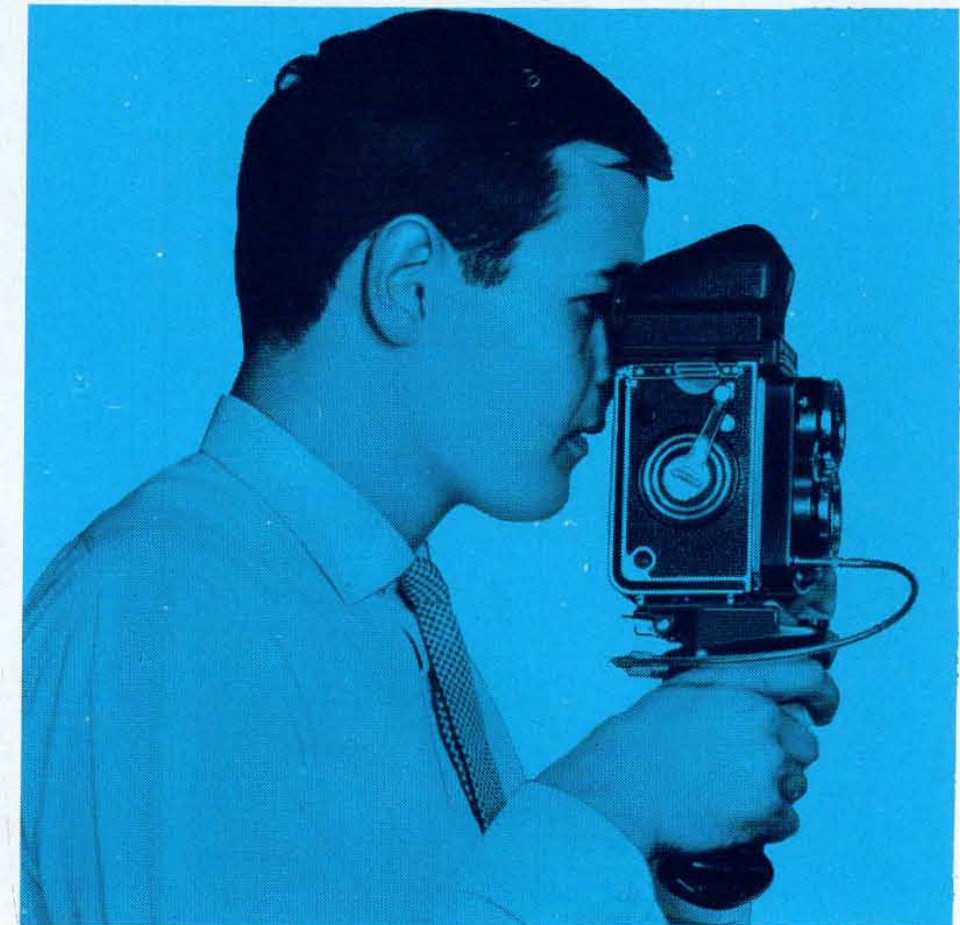
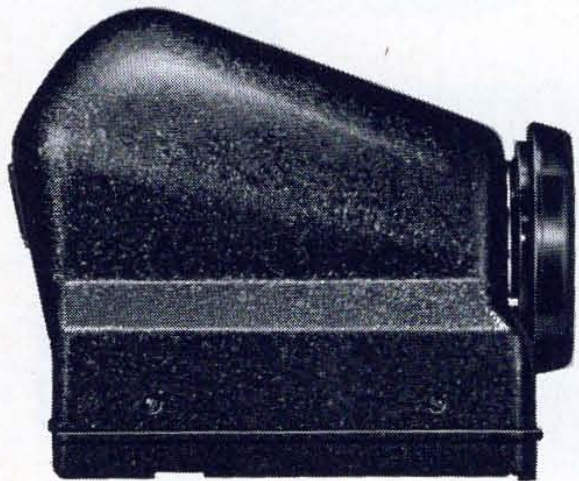

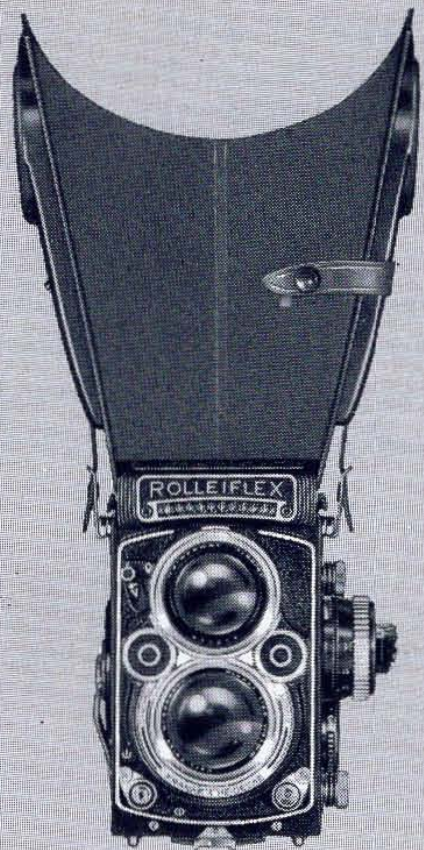

The Pistol Grip

As its name implies, this is a convenient handgrip with trigger and cable release for holding and for releasing the Rollei with the right hand. The left hand remains free for focusing the camera.

The pistol grip is specially suitable for action shots and rapid picture series and for convenient eye-level viewing with the frame finder or pentaprism. The front of the grip also takes the connecting bracket of an electronic flash gun. The Rolleiflex type quick release clamp simplifies fitting and removal of the camera. A safety lock prevents accidental releasing. A strap is available for the pistol grip to secure the grip and camera to the wrist. The pistol grip and Rolleiflex (see page 16) fit every Rollei model carrying the required clamping groove around the edge of the flange surrounding the tripod bush.

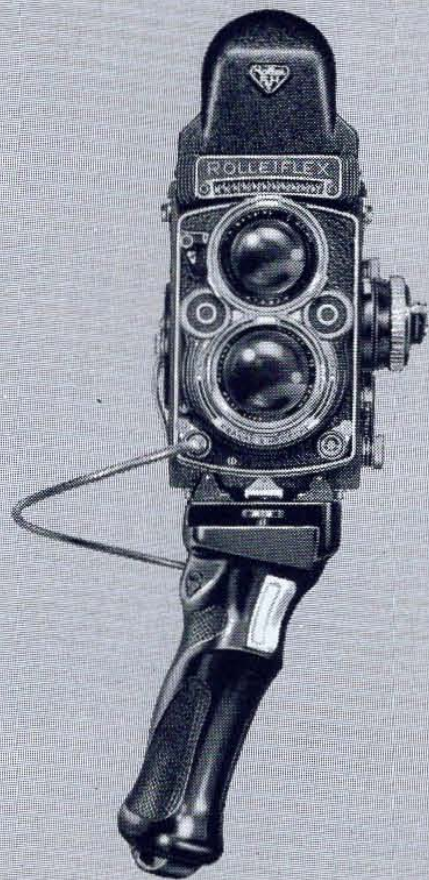

The Extension Hood with Binocular Magnifiers

This leather hood fits over the focusing hood for a dual purpose: the binocular magnifiers enlarge the finder image and permit viewing with both eyes while completely excluding all outside light. It is specially recommended for older Rollei models with ground glass screen and fixed hood and generally whenever the finder image is to be viewed with both eyes at 2-times magnification. The close fitting hood considerably increases the apparent brightness of the finder image. The two magnifiers are individually adjustable to the interocular distance. They automatically snap into position on opening the hood. A simple operation closes the hood again to a unit no larger than a spectacle case.

The Pistol Grip The Extension Focusing Hood



The Panorama Head

The Panorama Head

With the Rollei you can even manage to cover landscape views beyond the limits of the picture format. The panorama head gives ultra wide-angle coverage of landscapes. This tripod head has a rotating scale sub-divided for 10 exposures which cover a full 360° view by turning the camera progressively, shot after shot. The scale engages at each setting so that the individual pictures match up accurately and can be assembled to form a panorama. Often two or three exposures are sufficient to extend the normal view of the Rollei to an effective widescreen effect. The panorama head is available with Continental ($\frac{3}{8}$ inch) and English ($\frac{1}{4}$ inch) tripod bush and with a special sub-division of the rotating scale for the Tele-Rolleiflex.

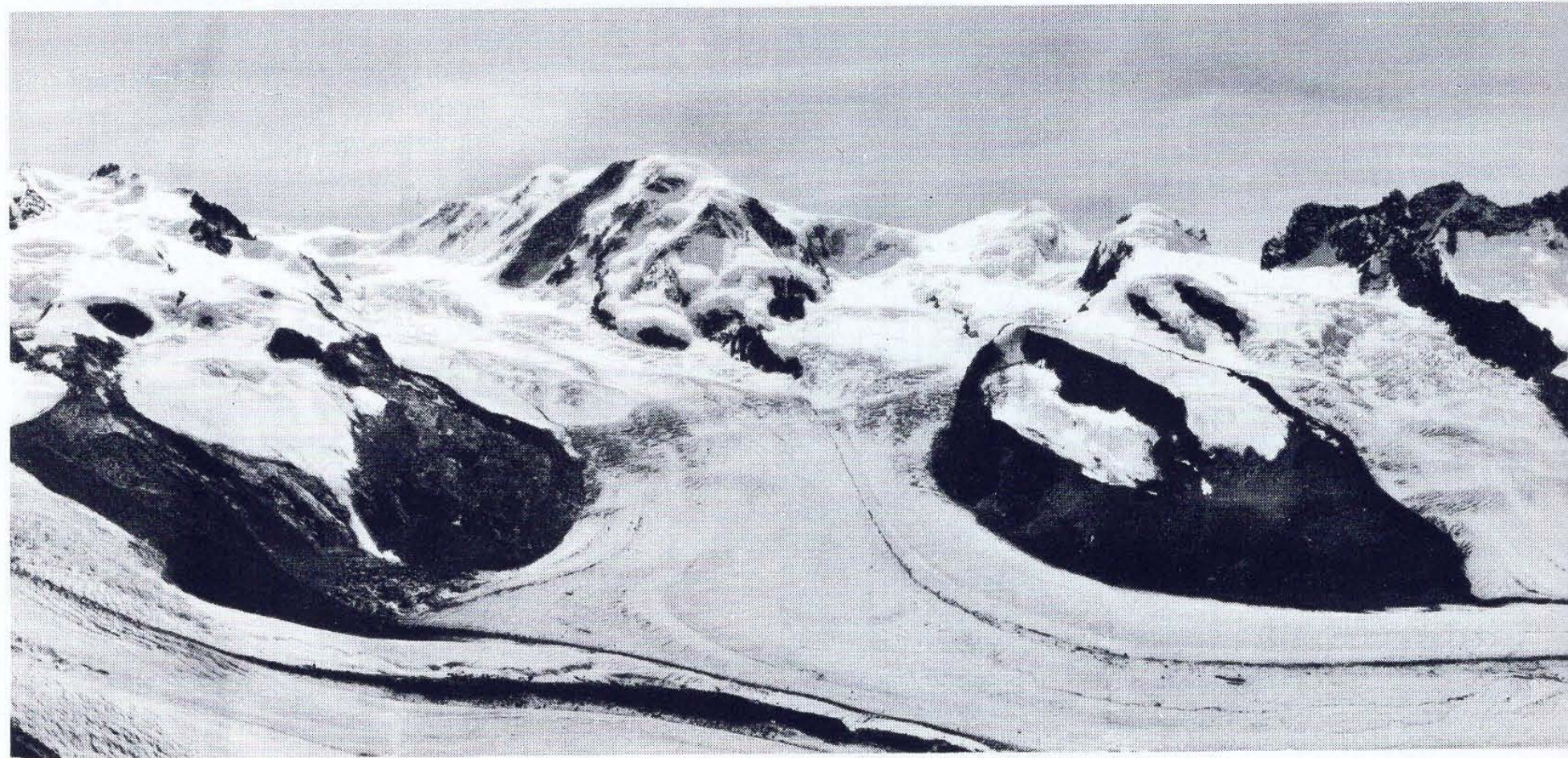
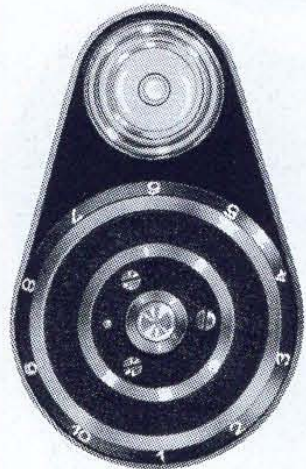

The Rolleifix Tripod Head

saves time when you have to mount the camera on a tripod. Instead of screwing it on or unscrewing, you simply slide the Rollei between the two retaining rails and clamp it tight with the locking lever. The pistol grip (page 13) uses the same quick-fitting system.

The tripod head remains permanently on the tripod or on the bracket of the electronic flash gun. That way you instantly and securely mount the Rollei and equally quickly remove it.

The Rolleifix Tripod Head



The Sheet Film and Plate Adapter. The Optical Glass Film Plane

The 2¼×2¼ inch (6×6 cm.) Sheet Film and Plate Back

Plates and the even more widely used sheet films (especially in colour) have a number of advantages: you can take single shots, use special copying and other emulsions, and process your negatives individually to get your picture without delay. This is the real value of the sheet film adapter for the Rollei. You use 2¼×3¼ inch (6×9 cm.) sheet films or plates to yield 2¼×2¼ inch (6×6 cm.) pictures.

The standard outfit consists of the adapter back, three plate holders and three sheet film inserts. The adapter back, plate holders and sheet film inserts are also available separately, as is the ground glass screen holder for direct focusing through the taking lens.

The Optical Glass Film Plane

For the utmost image sharpness, the optical glass film plane further increases the precision of the film track of the camera. The glass holds the film as flat as a plate to ensure maximum resolution of the finest image details.

The optical glass film plane outfit is suitable for the Rolleiflex models 3.5E3, 3.5F (with serial Nos. from 2,230,000 onwards), 2.8E2, 2.8E3 and 2.8F. The Tele- and the Wide-Angle Rolleiflex already incorporate the glass film plane in the basic outfit. Spare optical glass plates are available separately.

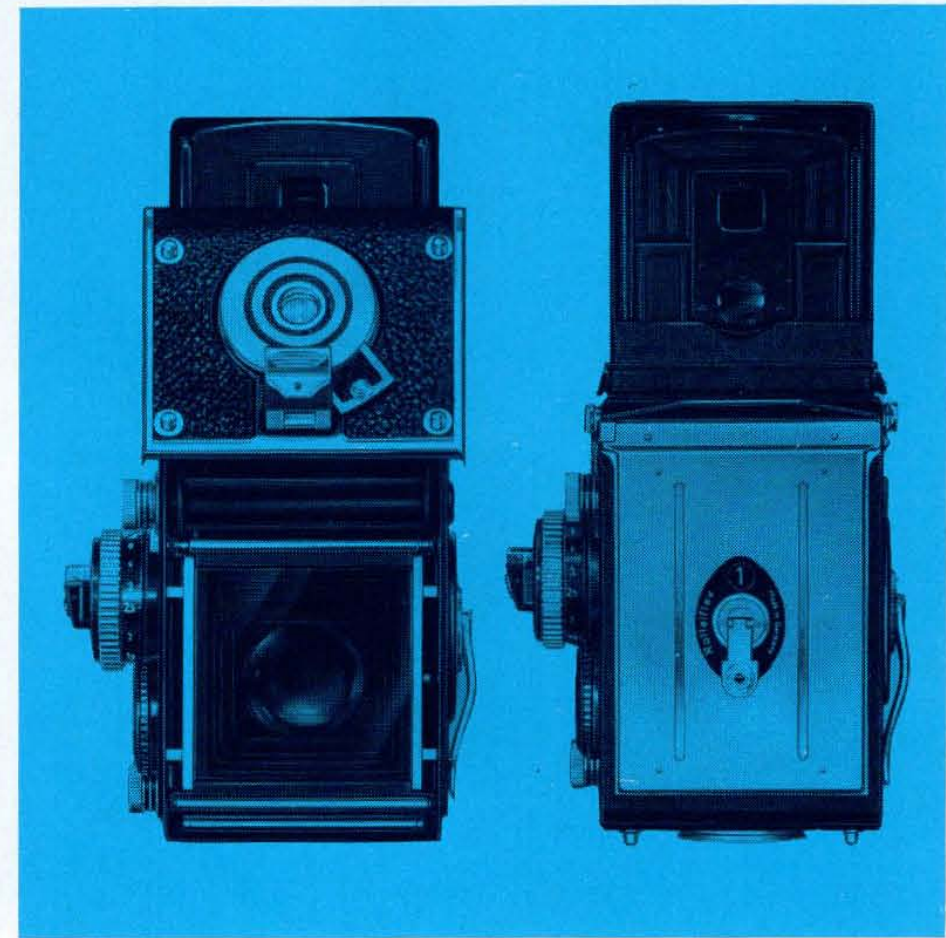
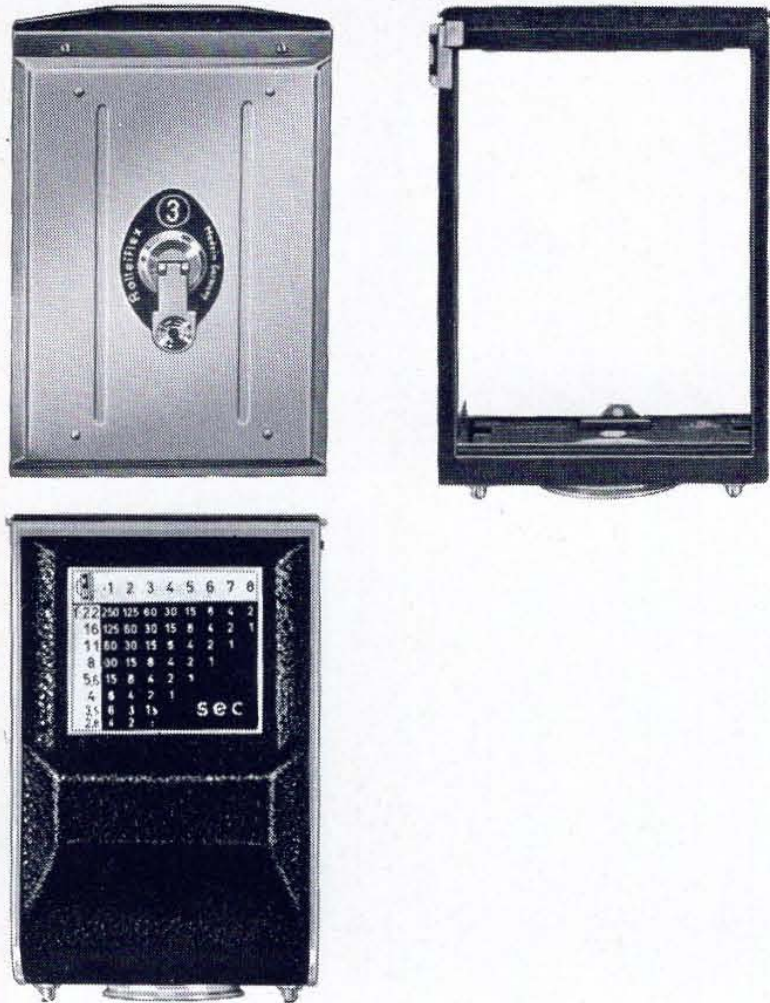

The Polaroid Land Back

This special attachment is intended for close-ups where immediate black-and-white prints (within 10 seconds) are required — for example pictures of damaged machine parts in industrial photography, finger prints for forensic work, fluorographic records of X-ray screens used in medical television radiology etc.

The Polaroid Land Back fits all Rolleicord and Rolleiflex cameras with removable focusing hood and lenses of 75, 80 or 135 mm. focal length. The unit consists essentially of two parts: the actual Polaroid back which replaces the camera back, and the Rolleicopi unit which fits between the camera body and the focusing hood.

Two sliding shutters provide light-tight protection for the film in the Polaroid back and engage in two positions. If the subject only fills half the image area, you can make two successive exposures on the upper and lower half of the picture area by operating a lever at the side.

In its central position the lever uncovers the full picture area. The settings for the full and half-frame positions are shown by symbols.

The following approximate subject distances and scales of reproduction are obtained for the different focal lengths with the camera lens set to infinity and the nearest distance ($3\frac{1}{2}$ or 3 feet, or 1 metre or 90 cm.) respectively on the focusing scale:

Focal length 75 mm.:	$8\frac{3}{4}$ inches (22 cm.) — 1 : 2
	$7\frac{1}{2}$ inches (19 cm.) — 1 : 1.7
Focal length 80 mm.:	$9\frac{1}{2}$ inches (24 cm.) — 1 : 2.2
	$8\frac{1}{4}$ inches (21 cm.) — 1 : 1.8
Focal length 135 mm.:	26 inches (66 cm.) — 1 : 3.7
	23 inches (58 cm.) — 1 : 3

Still larger scales of reproduction are possible with the Rolleinar sets 2 and 3:

The illustration shows an oscilloscope tube screen, photographed with the Rolleicord with $\frac{1}{50}$ second at f/8.

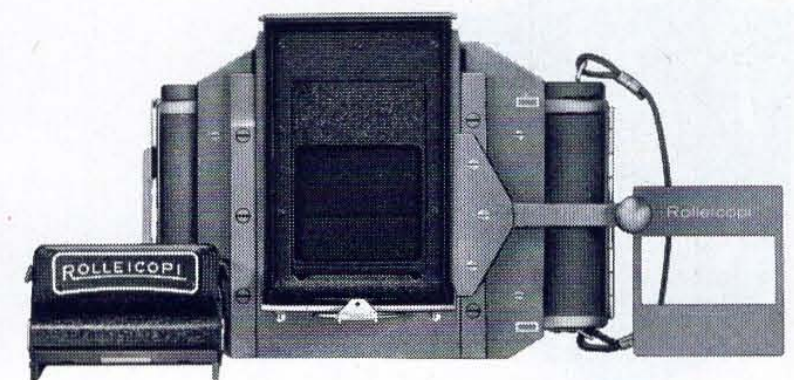
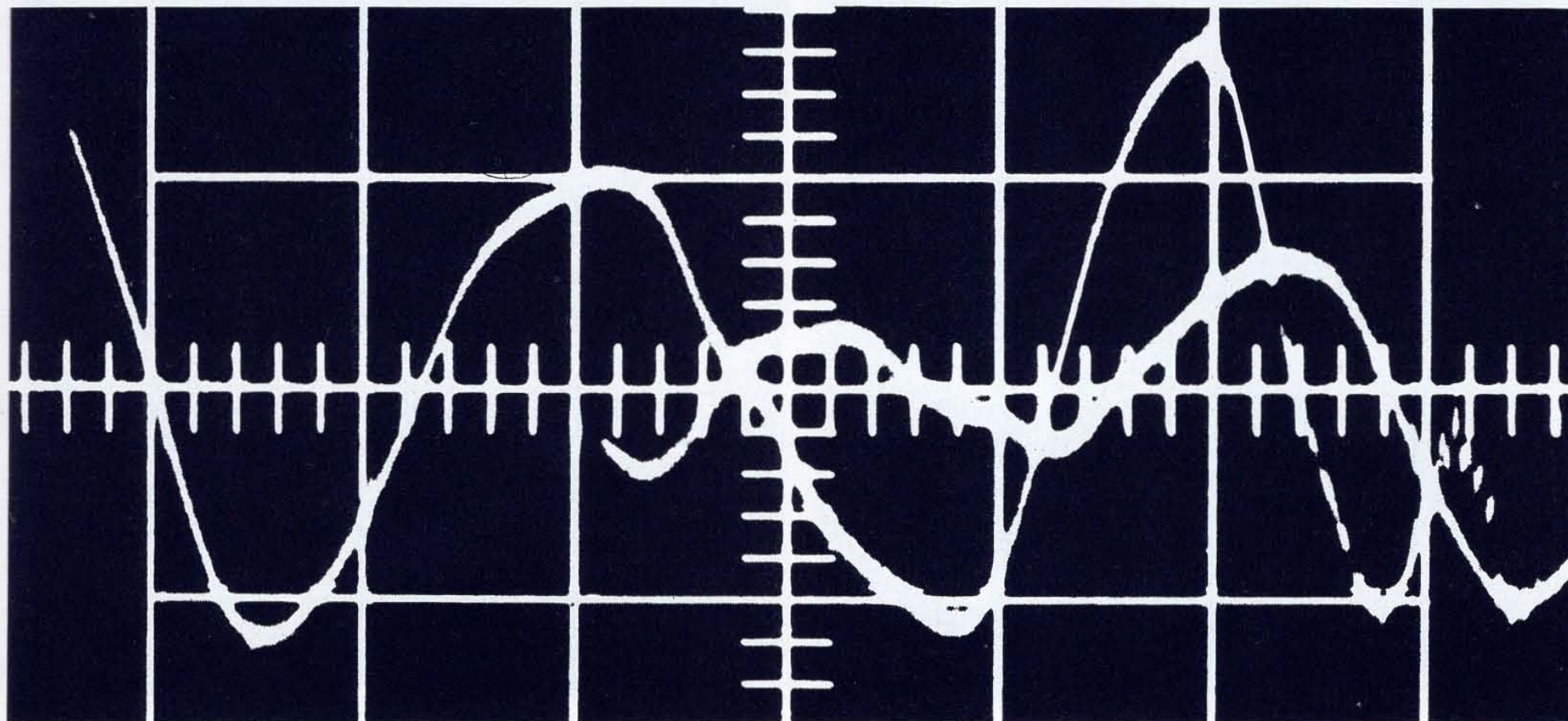

The Tele and Wide-angle Lens Units

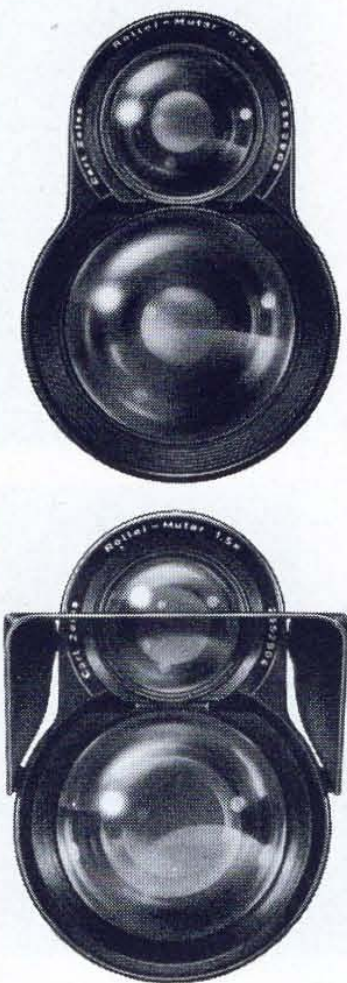

With its big image scale and large picture format the Rollei is equal to nearly all photographic jobs.

In special cases you may however want to use a different focal length. A long-focus lens enlarges the image scale of the subject, a shorter focal length includes a wider angle of view in the picture.

The Rollei-Mutar units are high quality optical attachments which change the standard focal length by a factor of 1.5 or 0.7 times, and modify the scale of reproduction and angle of view accordingly.

The Rollei-Mutar 1.5x converts the Rollei lens into a tele lens. It thus brings sport and action scenes, landscapes and distant details nearer to

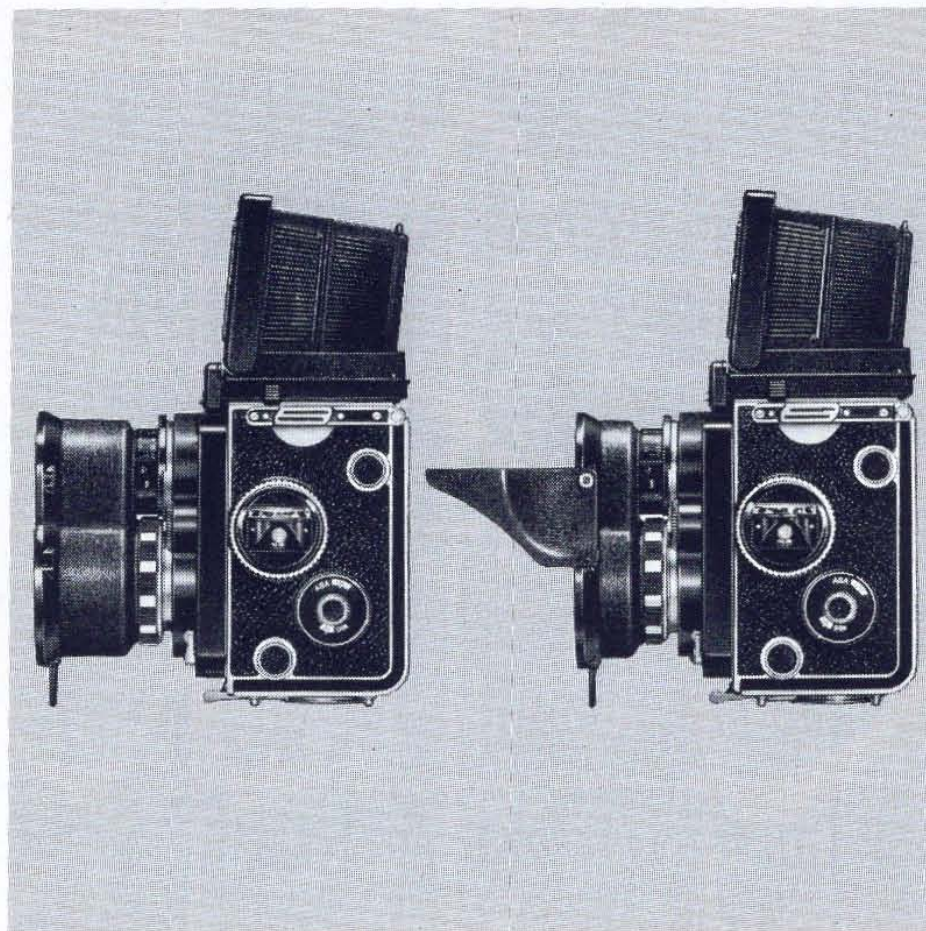

the camera. You can shoot from a greater distance and still record all detail on a larger scale.

The Rollei-Mutar 0.7x turns the Rollei into a wide-angle camera. It increases the field of view and reduces the required shooting distance. Even at close range the camera takes in the full subject; from a greater distance you have an additional field margin. That way you can easily cope with tall buildings, extended factory installations, broad landscapes and news shots in confined spaces.

The Rollei-Mutar units are twin optical systems which are mounted on the bayonet ring of the camera lens — instantly and simply like a filter. They modify only the focal length of the camera lens without affecting the aperture or the positive focusing facility. The finder image remains visible all the time.

Bayonet size	Lens	Focal Length	Angle of View	
			$2\frac{1}{4} \times 2\frac{1}{4}$ in. (6x6 cm.)	24x36 mm.
I ($2\frac{1}{4} \times 2\frac{1}{4}$ in.)	with Rollei-Mutar 0.7x	54 mm.	72°	43°
II (Not for Rollei-Magic or Rollei-Magic II)	without Rollei-Mutar	75 mm.	56°	32°
	with Rollei-Rollei-Mutar	109 mm.	40°	22°
III (Not for Tele-Rolleiflex)	with Rollei-Mutar 0.7x	57 mm.	69°	41°
	without Rollei-Mutar	80 mm.	53°	30°
	with Rollei-Mutar 1.5x	116 mm.	38°	21°

The Rollei-Mutar attachments have a size II bayonet mount because they were originally computed for the Planar f/3.5 lens.

Additional pairs of interchangeable adapter rings modify them for bayonet mount sizes I and III.

Required exposure value correction: — 0.5.

Accessories for the Rollei-Mutar units: lens hood; Rollei filters in special screw-in mount (size V); leather cases (for the Rollei-Mutars with lens hood in position), can also be combined to form a twin case for both Rollei-Mutar units.



Mutar comparisons:

above right:
wide-angle picture

below left:
normal picture

below right:
tele picture

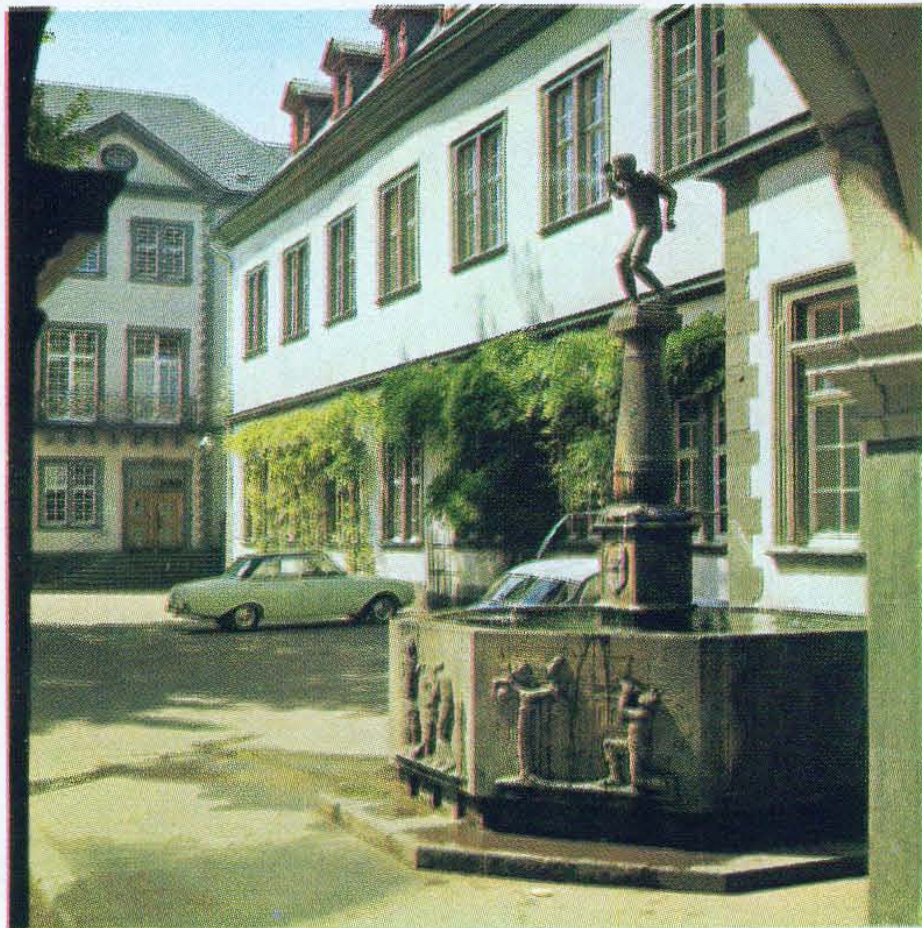

Cases and Containers

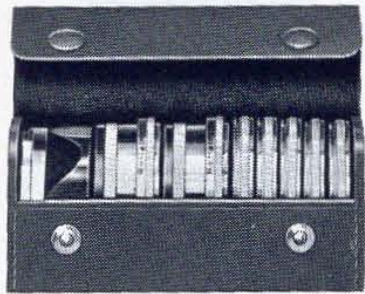

The Ever-Ready Case

is an elegant leather case available in different sizes with removable front for every Rollei.

Replacement Front for Ever-Ready Case

When you use the Rollei pentaprism on the Rolleicord, Rollei-Magic, Rolleiflex T, 3.5 F and 2.8 F, you don't need a second ever-ready case. You merely change the removable front for a special version with an appropriately modelled top.

Leather Case

with lens hood, two Rolleinar sets (1 and 2) and five filters; also available empty.

Leather Case

with lens hood and two filters; also available empty.

Metal Ever-Ready Case

This hermetically closing and water-tight light-alloy container protects the camera against extreme weather conditions, such as at high altitudes, in the tropics, during water sports and on expeditions. It has a hinged camera platform with a Rolleiflex-type quick release fitting. Available in two sizes for the Rolleiflex 4×4 and the 2¼×2¼ inch (6×6 cm.) models — Rolleicord, Rolleiflex T, 3.5 and 2.8. Complete with desiccant cartridge (also available separately) to absorb atmospheric moisture.

Other Accessories

Non-slip pads for the carrying strap. Different models of spare carrying straps to fit the various Rollei models. Spare plastic or chromium plated lens caps available in the different bayonet mount sizes. Protective leather cover for the exposure meter, fixes to the ever-ready case.

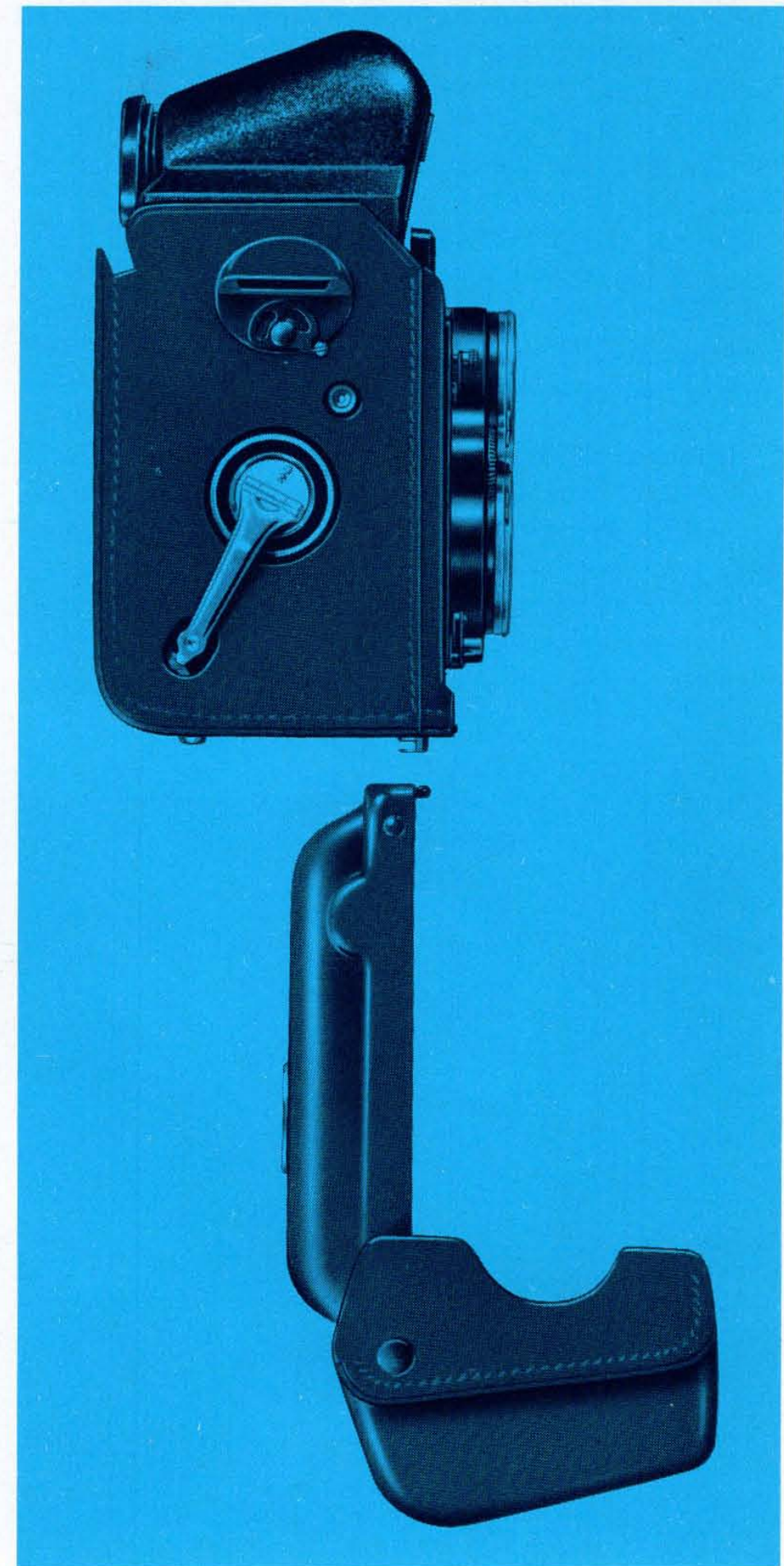

The Rolleimot Remote Release

The Rolleimot is an electric remote release for the $2\frac{1}{4} \times 2\frac{1}{4}$ inch (6×6 cm.) Rolleiflex and Rollei-Magic cameras. It consists of a transport and release system to release the shutter, advance the film and retension the shutter by remote control.

The Rollei is firmly mounted on the Rolleimot by the camera tripod bush. The release and film transport crank are linked to the unit. The motor is powered by four 1.5 volt batteries, or a 6 volt accumulator.

You operate your Rollei by a hand switch via a remote control cable which can be extended up to 650 feet (200 metres). Pressing the button releases the camera, letting go of the button gets it ready for the next shot. During the film transport cycle a red signal lamp lights up on the remote control switch. When it goes out, the camera is ready for the next exposure. The same lamp also indicates the end of the film.

The Rolleimot is particularly useful whenever you want to take a subject at fairly close range, but remain yourself out of sight. Examples are unobtrusive feature photography, technical records, especially in inaccessible or dangerous locations — and wild-life pictures out of doors.

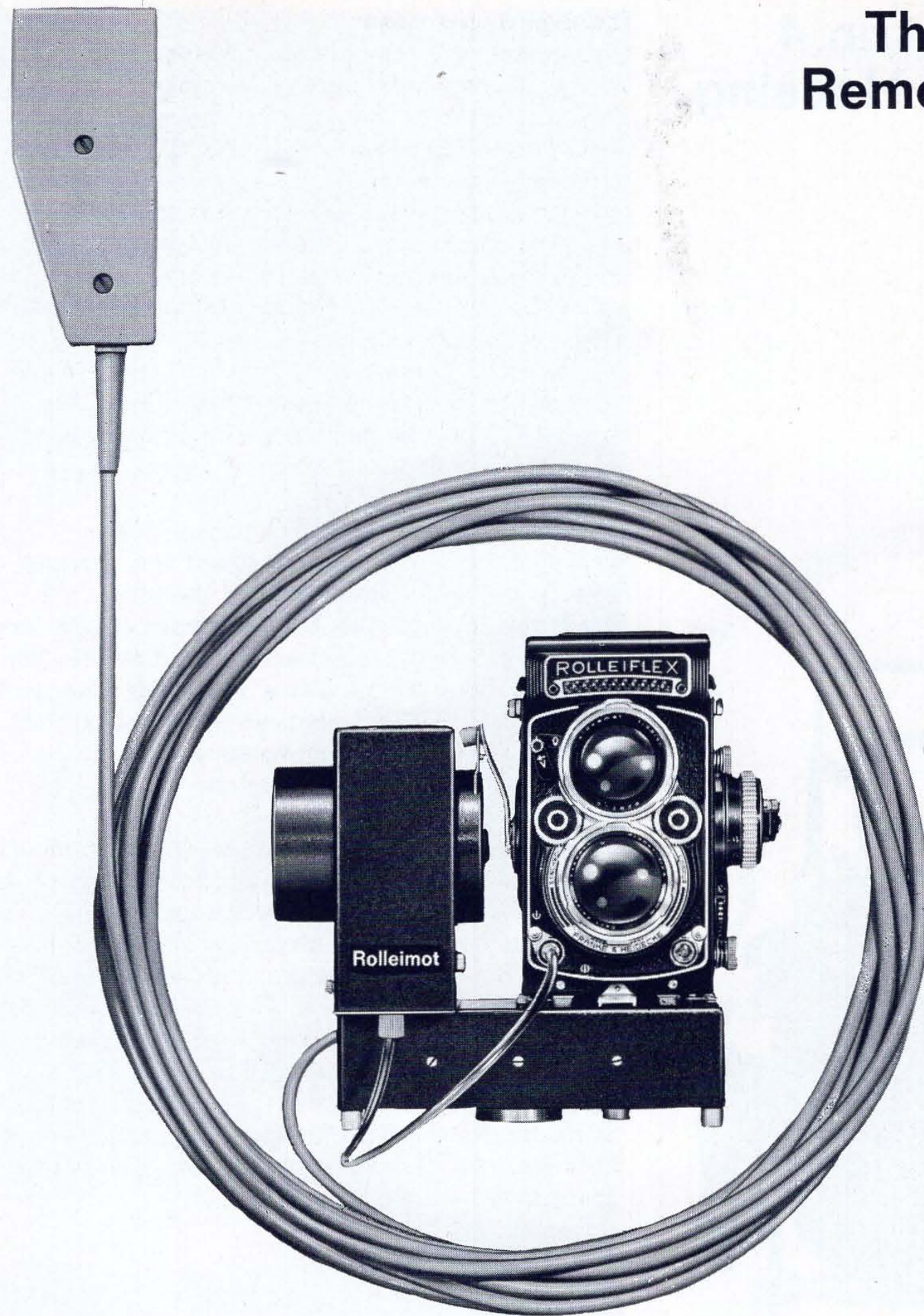

The Rolleimarin 4 Underwater Housing

The Rolleimarin is a non-corroding and pressure-proof camera housing suitable for diving depths down to about 55 fathoms (100 metres). It is intended for scientific, industrial and sportive applications of underwater photography with the Rolleiflex.

The Rolleiflex is specially suitable for underwater shooting since you can set all the controls in the customary way. The difference in the refractive indices between air and water does not affect accurate focusing: you check the image sharpness in the finder. At the low lighting levels under water and at the short subject distances involved there, the positive and reliable focusing system of the Rollei is a special asset.

The finder image is easily observed while swimming along. The shutter speed and aperture settings are in constant view for checking. The frame finder is adjustable to compensate for parallax at the appropriate subject distance. For rapid distance settings above and under water (with allowance for the different refractive index) the focusing knob carries two distance scales, calibrated in both feet and metres.

Even close-up shots are possible. A hinged mount in front of the lenses takes a special version of a Rolleinar set. This permits switching over the camera as required for close-ups or normal shots. The two Rolleinar sets with parallax compensation cover distances from 49 to 23 $\frac{3}{4}$ inches or 135 to 60 cm. (set 1), and from 23 $\frac{3}{4}$ to 15 $\frac{3}{4}$ inches or 60 to 40 cm. (set 2), measured from the front window of the Rolleimarin. If a filter is to be used all the time in the Rolleimarin 4, an unmounted filter disc can be inserted in the lens mount before diving, and held flat there.

For flash shots a special flash gun is available with battery-capacitor firing circuit. This has an Edison screw socket but will take S.C.C.-capped and capless bulbs with the aid of adaptors. To light up the full subject field even for close-up shots, the lamp head can be tilted and engages in three distinct positions. An additional flash unit can be mounted on the other side of the underwater housing to provide shadowless illumination of subject and to reduce the exposure time.

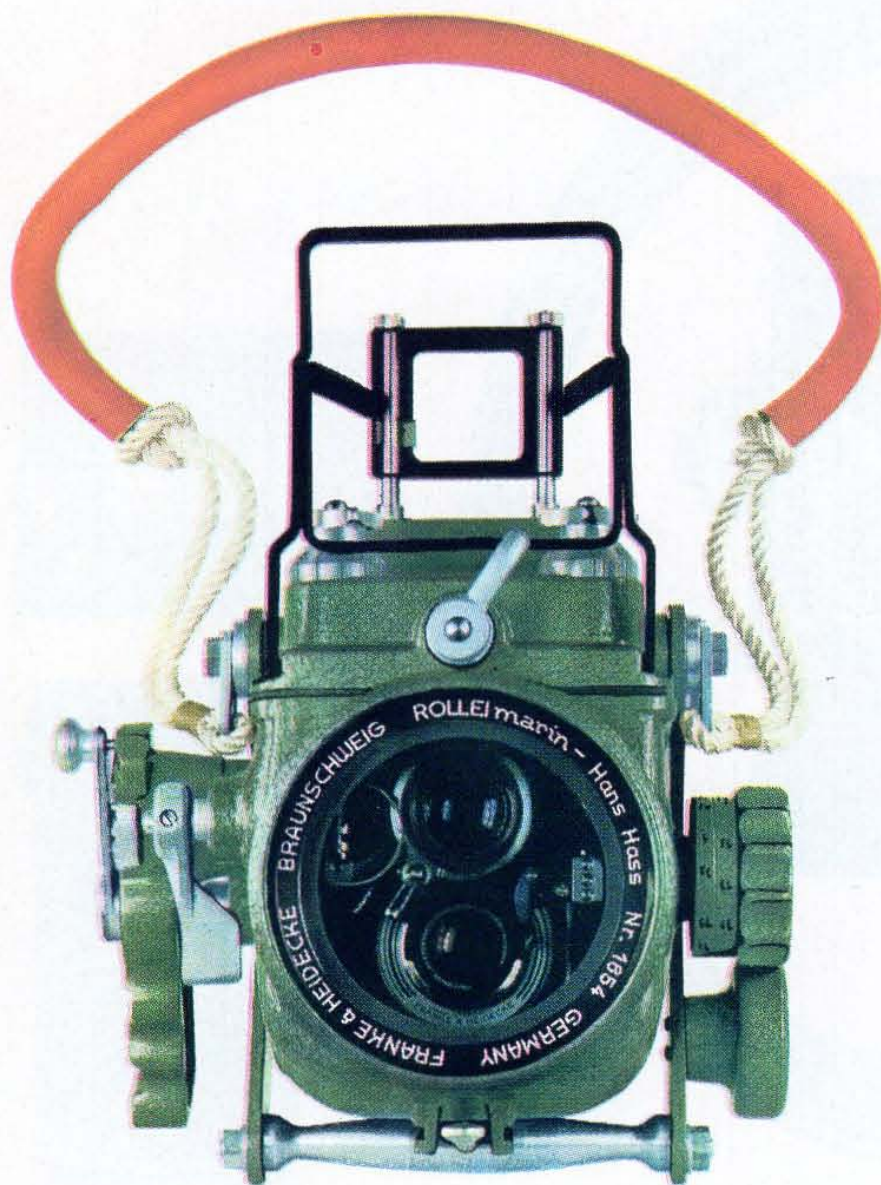



„Sea Anemone”
Kodak Ektachrome, 1/30 sec. at f. 8,
flash.

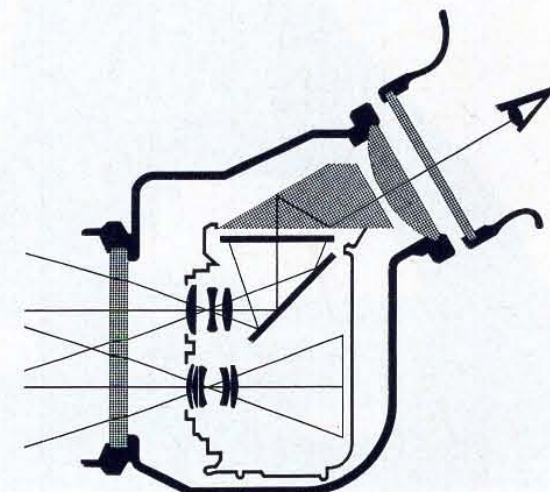

The Micro Attachment



This special attachment meets the requirements of the microscopist with a Rollei — and is universally adaptable to all applications of photomicrography. It extends the range of the Rollei beyond close-ups (with the Rolleinar lenses) to become more useful than ever for scientists, research workers, students and advanced amateurs.

The outfit consists of two parts: the Rollei micro tube for clamping to a microscope, and the Rollei microprism with focusing eyepiece for constant direct observation of the subject. Even with the micro tube — which is used alternately in front of the two camera lenses — you can take photomicrographs of static subjects after first focusing through the viewfinder system. With the microprism and tube combined the field of view and image sharpness can be checked even during the exposure. The Rollei can then cover all aspects of photomicrography. The micro tube is available with a bayonet ring in three different sizes, to match the lens mount diameter of the camera:

- I (6×6) for 2¼ × 2¼ inch (6×6 cm.) Rolleis with Tessar, Xenar or Triotar lenses (also for the Rolleiflex 4×4);
- II for the Rolleiflex with Planar or Xenotar f/3.5 lens;
- III for the Rolleiflex with Planar or Xenotar f/2.8 lens.

Spare bayonet rings are available separately so that you can use the same micro attachment with different Rollei cameras.

The special advantages of the Rollei for photomicrography include:

Optimum coverage (with an appropriate microscope eyepiece) of the circular microscope image by the square 2¼ × 2¼ inch (6×6 cm.) and 1⅝ × 1⅝ inch (4×4 cm.) Rollei formats.

Pinsharp definition and maximum detail reproduction to permit unlimited enlargement.

This is particularly important in colour micrography.

To obtain the full microscope magnification (relative to a standard viewing distance of 10 inches or 25 cm.) the Rollei negative requires additional enlargement. The degree of enlargement, according to the focal length used, is as follows:

Image size	2¼ × 2¼ in. (6×6 cm.)	1⅝ × 1⅝ in. (4×4 cm.)	
Focal length	80 mm.	75 mm.	60 mm.
Required enlargement (Diameters)	3.1 x	3.3 x	4.2 x

Example: With a microscope magnification of 100x a 2¼ × 2¼ inch negative taken with the 75 mm. lens records the image in the negative with a 100/3.3 = 30x magnification. A 3.3 diameter enlargement again restores the 100x magnification in the final print.



The Universal Projector



With this top-class unit projection becomes really easy.

You can show slides of all sizes: $2\frac{1}{4} \times 2\frac{1}{4}$ inches (6×6 cm.), $1\frac{5}{8} \times 1\frac{5}{8}$ inches (4×4 cm.), 24×36 mm., 28×28 mm., 18×24 mm., 12×17 mm., and any intermediate format. Your slide collection is not tied to any image size. It doesn't matter what camera you use, and you can show other people's slides as well.

The Rollei projector is supremely easy to operate. You direct the show from the midst of your audience. The remote control unit keeps track of the whole procedure: slide changing forward or backward (to repeat pictures already shown) and image sharpness.

There are seven lenses for the Rollei projector — including two special focal lengths: 45 mm. f/2.8 (for 12×17 mm. transparencies only) and 110 mm. f/2.8 (exclusively for $1\frac{5}{8} \times 1\frac{5}{8}$ inch and 24×36 mm. slides.)

The Vario-Heidosmat permits particularly impressive shows. This universal f/3.5 lens has a continuous zooming range from 110 to 160 mm. You simply make the picture larger or smaller. So you can control the final screen image size independently of the projection distance or the size of the room available.

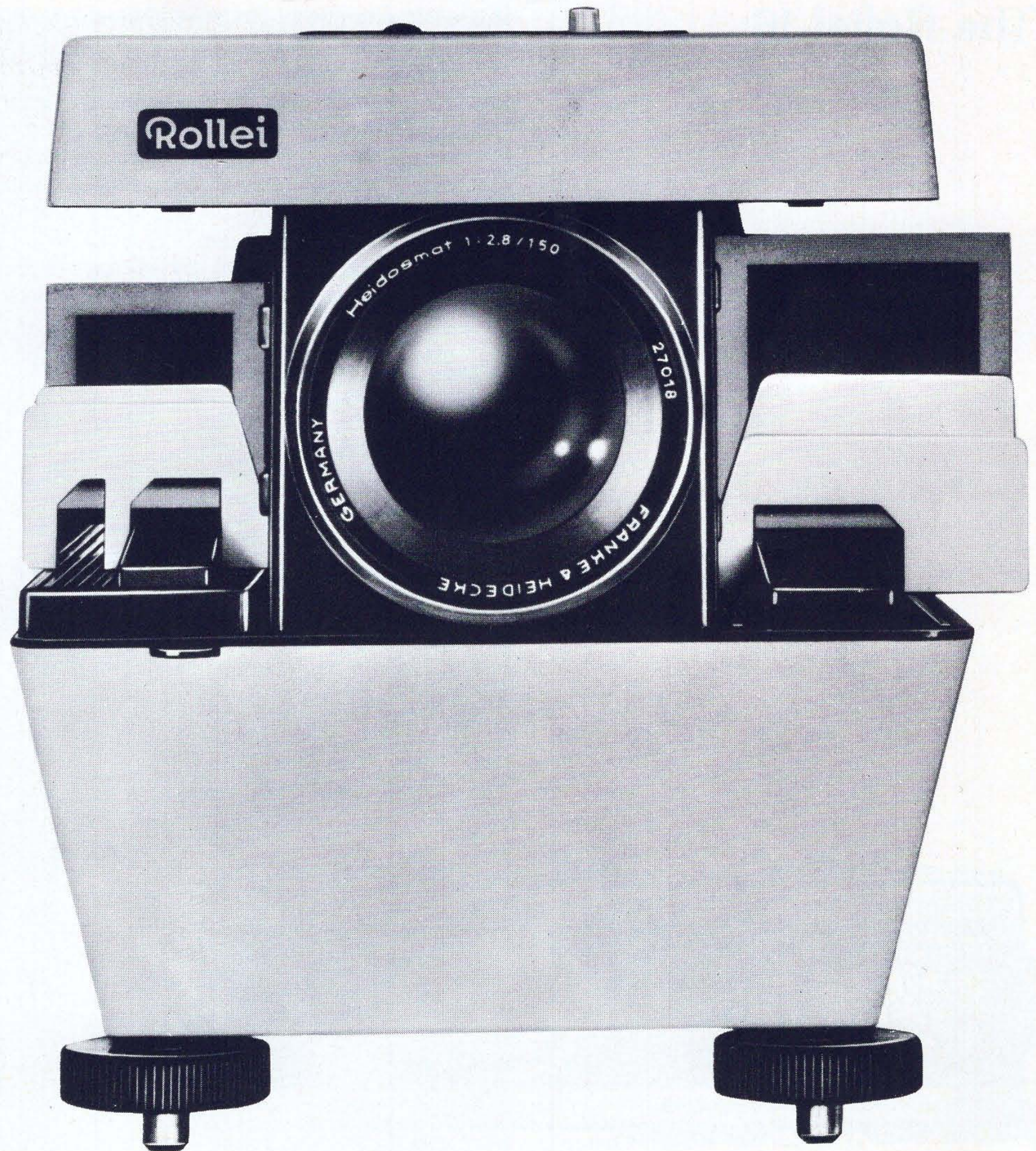

The Rollei 16

This automatic pocket Rollei is a special kind of practical accessory. It is practical, because you can always carry this camera with you. It is small and weights virtually nothing. So it supplements your larger Rollei whenever you come across something unusual: on walks and hikes, window shopping in town, at parties or on holidays. Wherever you go the Rollei 16 is really handy: in a lady's handbag and even in a car. (Honestly, how often have you missed potential pictures because you left your camera behind?)

You can take any shot with the Rollei 16. Many Rollei photographers have already got themselves this pocket Rollei as a second camera.

Here are its features in a nutshell: Image size 12×17 mm. 25 mm. Zeiss Tessar f/2.8 lens. Focusing range from infinity to 16 inches (0.4 metres). Programmed shutter with automatic exposure control to cover exposure times from 1/30 to 1/500 second and apertures from f/2.8 to f/22. Filter factor correction settings. Provision for manually set time exposures (B) and flash shots. Wide range of accessories, including tele and wide-angle Mutar lenses, giving three effective focal lengths: 16 mm. (65° angle), 25 mm. (45°) and 42 mm. (21°).

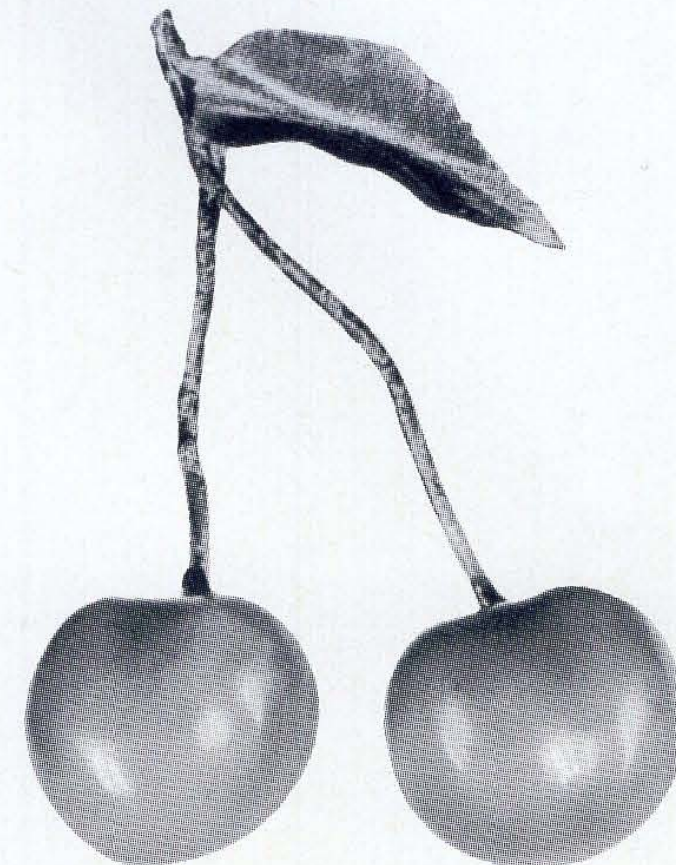

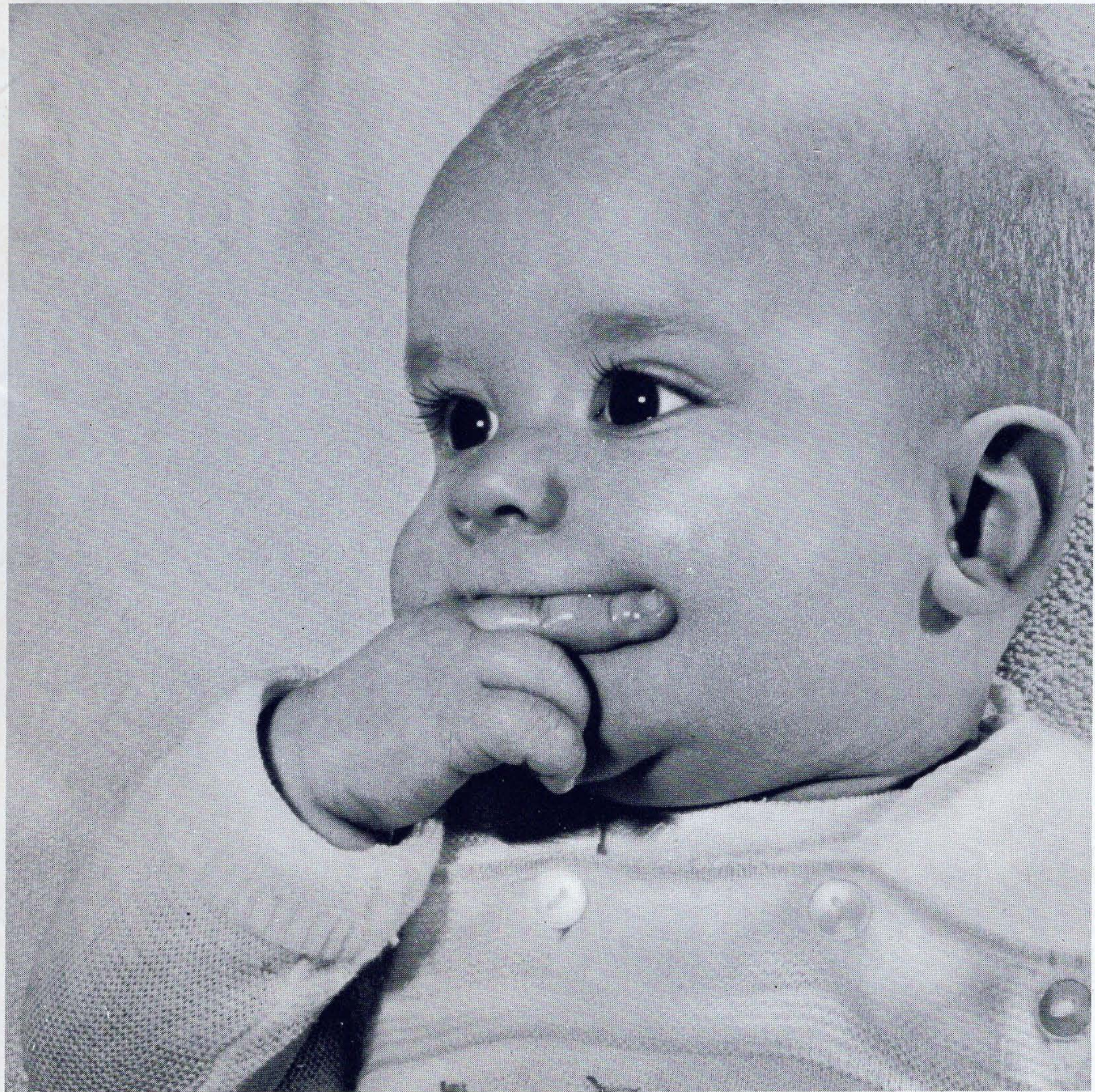

Original negative format 12 × 17 mm.



Ask your photo dealer for the prices of the useful accessories. When ordering accessories always quote the camera serial number and the lens number.

Go and see your photo dealer. He will be happy to advise you — without obligation.

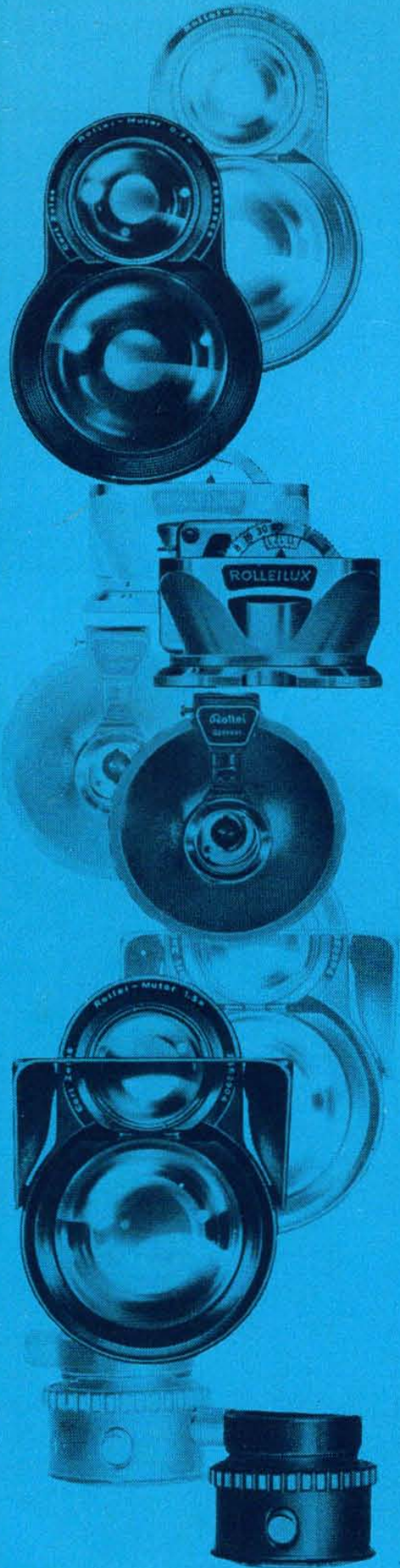

Honeywell

PHOTOGRAPHIC

We reserve the right to modify delivery, technical specifications and prices.

Rollei Werke, Franke & Heidecke, Braunschweig,
West Germany.

E 0365 Printed in Germany
D.B.P. and D.B.G.M. — Brev.s.g.d.g. — Foreign patents