

ZEISS  
IKON



# CONTAFLEX I

INSTRUCTIONS FOR USE



## THE CONTAFLEX I CONTROLS

- 1 Focusing mount
- 2 Focusing scale
- 3 Distance setting index
- 4 Depth of field scale

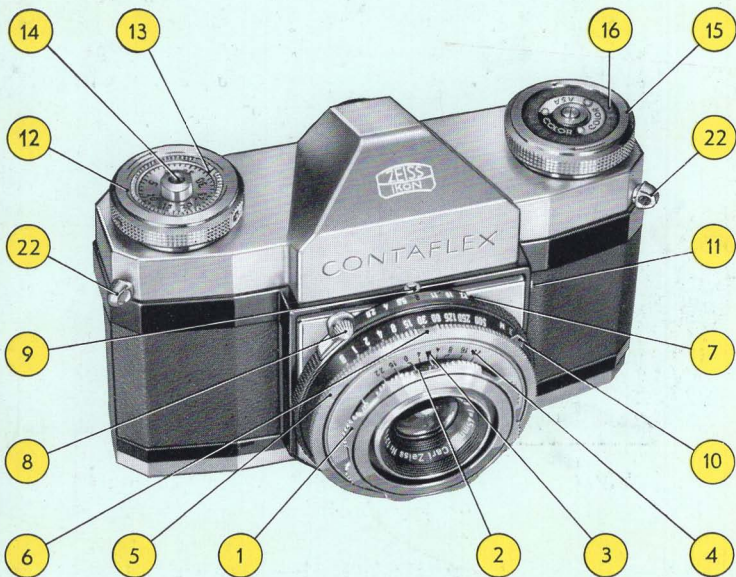

- 5 Shutter speed setting ring
- 6 Shutter speed setting index
- 7 Aperture ring
- 8 Aperture setting knob
- 9 Aperture setting index
- 10 Synchronizing lever

For further camera controls see page 42

## THE CONTAFLEX I

made by ZEISS IKON AG., STUTT GART, combines the advantages of a miniature with those of a reflex camera. Its design is based on many years of experience in the manufacture of precision cameras. While it has been produced for the advanced amateur, it is of equal value to the professional worker, the scientist, and the technical photographer.

The sensible lay-out of the various controls and scales, and the coupled shutter tensioning and film transport, are designed for efficient operation of this small and handy camera even under the most difficult conditions.

The large, bright, parallax-free finder is combined in one eyepiece with the range-finder systems. These, together with the outstanding performance of the world-famous 1 3/4 inch (45 mm) ZEISS TESSAR f/2.8 lens, ensure pin-sharp pictures every-time which will always give pleasure.

To make the most of all the new features



of your CONTAFLEX please study this instruction booklet carefully. While doing so, open out the front and back cover pages for easier comparison of the description with the illustrations of the camera.

Start by practising the various operations of picture taking without a film in the camera. If you are doubtful on any point, your photo dealer will be glad to help you with further advice and information.

We are sure that you have made a wise choice in buying the CONTAFLEX. We would like to share your enjoyment, and we shall appreciate it if you care to send us some of the outstanding pictures you have taken with your CONTAFLEX.

*The picture on page 2 of the cover was taken with the CONTAFLEX at  $\frac{1}{250}$  second at f 4 in bright sunlight.*

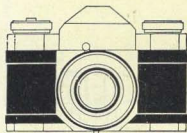

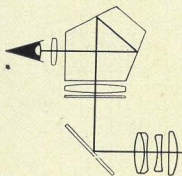

## CONTAFLEX I FEATURES

The most prominent feature is the *large bright finder* which shows the picture in almost natural size before you take it. A stepped Fresnel-type field lens evenly illuminates the parallax-free finder image right into the corners. You observe it through a pentaprism which shows an upright and right-way round picture at eye-level. The finder indicates the correct field of view even with the lens attachments or the supplementary lenses for close-up photography.

The *focusing system* with the split-image rangefinder and the ground glass screen ring within the finder measures the exact distance and automatically sets the lens.



The world-famous ZEISS TESSAR  $f/2.8$  lens with a focal length of  $1\frac{3}{4}$  inches (45 mm) yields pin-sharp images on black-and-white or colour film. It is of course colour corrected and coated.



The *Synchro-Compur shutter, model MXV*, has shutter speeds from 1 to  $\frac{1}{500}$  second

as well as a B setting for time exposures of any duration. The built-in flash contact permits synchronization with all types of flash at the fastest shutter speed. It is also fitted with a *self-timer*.

All settings are visible at a glance from above.

The bright, parallax-free, viewfinder and rangefinder system, the *spring-loaded pre-selector iris* and the coupled film transport and shutter tensioning mechanism make the camera ready for action at a moment's notice.

The camera takes 24 x 36 mm negatives on 35 mm miniature film available in standard daylight cassettes, daylight refills, dark-room refills, or as bulk film. With the *special cassettes* the film can be changed in daylight after any number of exposures without rewinding.

The *removable back* simplifies loading and unloading as well as cleaning of the camera.

The *all-metal body* guarantees the utmost mechanical precision of all components — the hall-mark of ZEISS IKON products.



## HANDLING THE CAMERA

### *Setting the Aperture*

Depress the button (8) and at the same time rotate the black milled ring (7) carrying the aperture scale until the required aperture number is opposite the index (9). If necessary, the diaphragm can also be set to intermediate values. When making some consecutive exposures it is recommendable to check the setting before each exposure. As the aperture ring clicks into position at each setting, you can even set the aperture in the dark by touch only. In that case start from one end position

2,8 ●  
4 ●  
5,6 ●  
8 ●  
11 ●  
16 ●  
22 ●

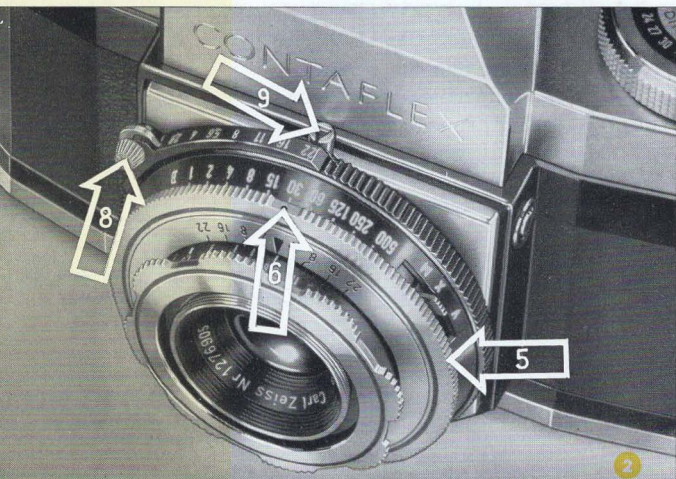



and count the clicks to the required setting. The aperture can be adjusted whether the shutter is tensioned or not (see next section).



### *Setting the Shutter Speed*

Rotate the chromium plated milled ring (5) until the black dot (6) is opposite the required speed figure (see Fig. 2). The milled ring clicks into position at each setting; this precludes intermediate speeds. The numbers indicate fractions of a second (thus 60 stands for  $\frac{1}{60}$  second, and so on). When set to B, the shutter remains open as long as the release button (14) is depressed (see page 20). For setting the self-timer see page 24.

To tension the Synchro-Compur shutter turn the winding knob (12) in the direction of the arrow **as far as it will** go. This at the same time advances the film by one frame. The coupling of the film transport and shutter tensioning makes double exposures and blank frames impossible. All shutter speeds can be set either before or after winding the film. Keeping the shutter tensioned does not harm it in any way.



*Important*

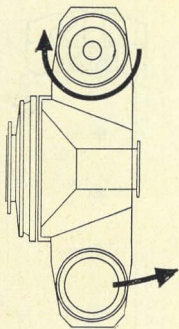

*A Useful Hint:* When winding the knob don't just twiddle it round with two fingers like a screw. A much more convenient and quicker way is to swing both hands simultaneously in opposite directions, with one hand holding on to the camera body and the other gripping the winding knob (Fig. 3).

When winding the shutter, please note that the winding knob (12) should be turned until a positive resistance is felt, otherwise the shutter may remain closed when operating upon being released.



## *Setting the distance*

The built-in coupled rangefinder system sets the camera to the correct distance. When you look through the finder eyepiece (20) you will see a clear circle enclosed by a ground glass screen ring in the centre of the field of view. This circle is cut in two by a horizontal line (Figs. 4 and 5). You can measure the subject distance in two ways:

- 1. Sight a vertical line (e. g. the edge of a wall, or a tree trunk) through the finder. On turning the focusing mount (1), the image in the upper half of the circle will move relative to the lower half. When the two halves of the image are exactly aligned, the lens is set to the correct distance.*
- 2. If the subject shows no prominent verticals, observe the image in the ground glass ring. Turn the focusing mount (1) to or fro until this image on the ground glass is pin sharp.*

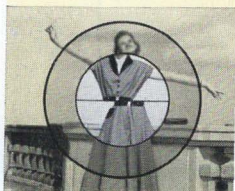
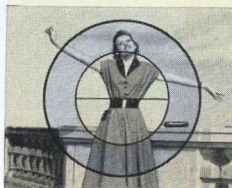
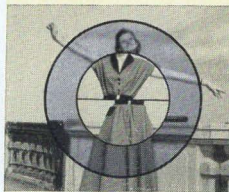

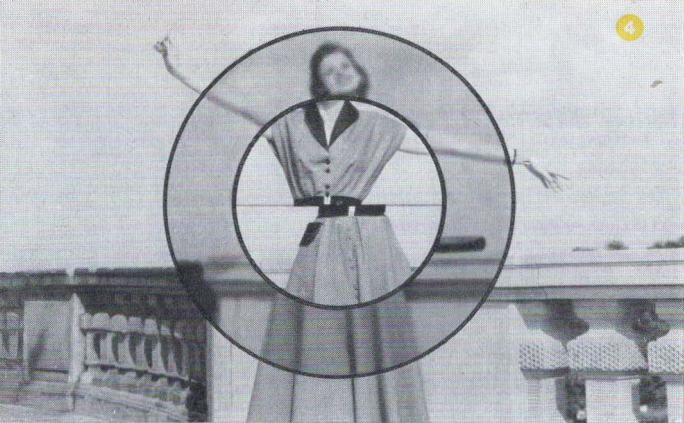

It is immaterial which method you use; in either case the lens is automatically set to the required distance.

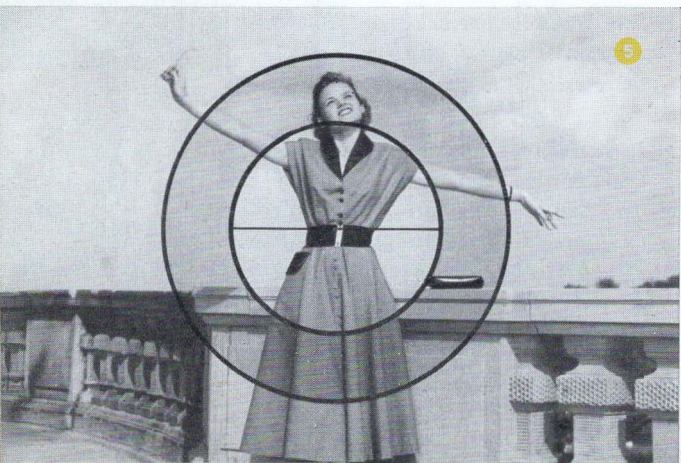

### *The Depth of field scale*

The sharp definition of the lens is not limited to subjects at the exact focused distance, but also covers a certain range in front of, and behind, this point. That zone of sharpness is comparatively small at full aperture ( $f/2.8$ ), but increases the more you stop down the lens.

The depth of field scale (4) shows the extent of this zone at various aperture settings. Two series of aperture numbers are engraved for this purpose to the left and right of the distance setting index (3). The figures on the focusing scale (2) opposite these aperture numbers then indicate the extent of the depth of field. For

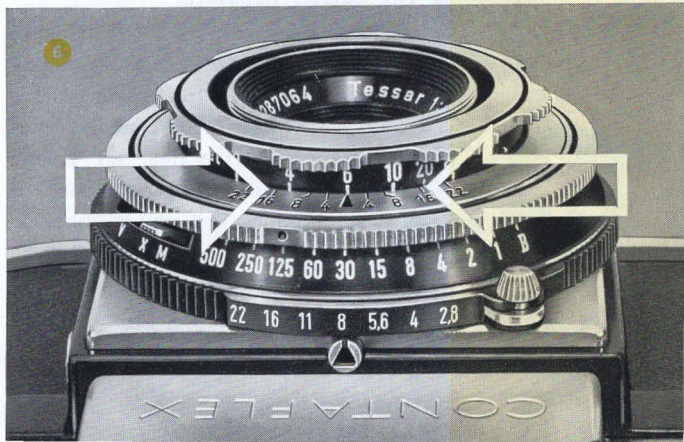
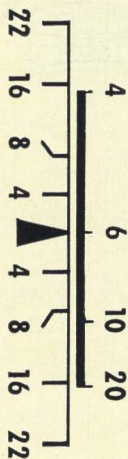



instance, with the lens set to 6 feet (Fig. 6), the left-hand figure 8 is opposite about  $4\frac{1}{2}$  feet, and the right-hand figure 8 opposite about 9 feet. Thus for a subject 6 feet away and with the lens stopped down to  $f/8$ , everything between about  $4\frac{1}{2}$  and 9 feet will be sharp. The table on page 16 gives more exact values.

You can equally go about it the other way round and measure with the range-finder the nearest and farthest points of the subject that have to be sharp. Then simply find the required aperture from the depth of field scale.

For technical reasons there is a second scale below the focusing scale (2), but it has no bearing on the operation on the CONTAFLEX.

### *The Correct Exposure*

can be obtained from tables or determined more accurately with the ZEISS IKON IKOPHOT RAPID photo-electric exposure meter. The exposure time (shutter speed) depends on the speed of the film, the general subject brightness, the aperture, and the factor of any filter that may be used. Do not stop down further than necessary to



make sure of the depth of field you want. Otherwise you may need long exposure times which increase the risk of camera shake, for the smaller the aperture the longer you have to expose. The ZEISS IKON IKOPHOT RAPID exposure meter directly shows the shutter speed corresponding to each aperture. A special model is available calibrated for the shutter speeds of the CONTAFLEX I.



*Remember these Basic Settings:*

Outdoor shots in bright sunshine, with 26° BSI (32 ASA) film:

Aperture  $f/8$

Shutter speed  $1/125$  second

Outdoor shots with overcast sky, with 26° BSI (32 ASA) film:

Aperture  $f/5.6$

Shutter speed  $1/60$  second

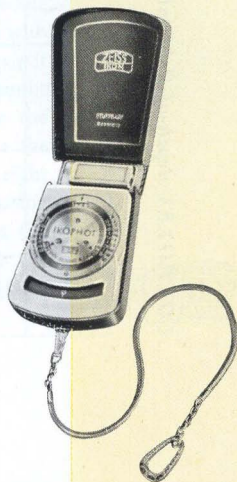

*CONTAFLEX depth-of-field table*

Dis- tance feet	Depth of field at aperture:						
	f: 2.8	f: 4	f: 5.6	f: 8	f: 11	f: 16	f: 22
∞	48' ∞	33'6" ∞	24' ∞	16'9" ∞	12'3" ∞	8'6" ∞	6'3" ∞
20'	14'1" 33'2"	12'5" 47'3"	10'10" 107'	9'2" ∞	7'6" ∞	6'1" ∞	4'9" ∞
10'	8'2" 12'1"	7'5" 13'9"	7'2" 18'4"	6'3" 22'11"	5'7" 46'3"	4'8" ∞	4' ∞
6'	5'9" 7'6"	5'7" 8'	4'7" 8'2"	4'1" 9'10"	3'8" 12'9"	3'1" 25'7"	3'2" ∞
4'	3'8" 4'4"	3'7" 4'1"	3'6" 4'8"	3'3" 4'11"	3'1" 5'7"	2'9" 6'11"	2'4" 9'1"
3'	2'10" 3'2"	2'8" 3'3"	2'7" 3'6"	2'6" 3' 8"	2'4" 4'	2'2" 4'9"	1'11" 6'1"



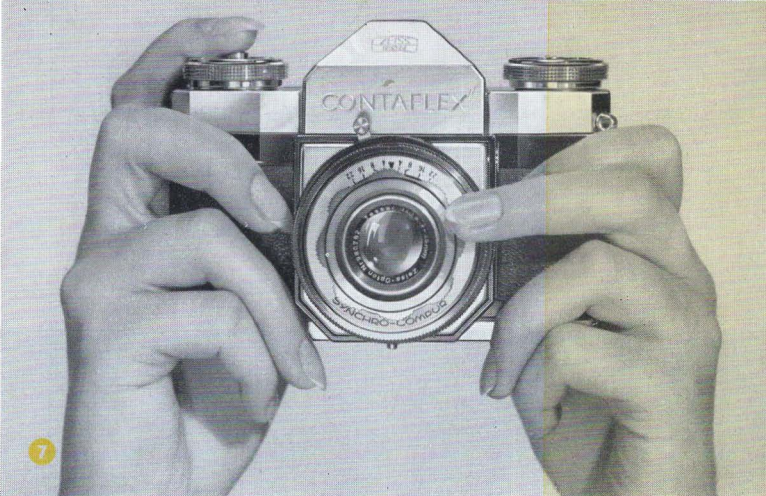

## TAKING THE PICTURE

### *Holding the camera*

Hold the CONTAFLEX perfectly still while exposing. Support the camera body with the palm of both hands and firmly grip it with the fingers (Fig. 7). Press the thumbs against the back of the camera. Use the second finger of the left hand to rotate the lens mount (1) for focusing, and the right index finger to press the release button (14). Press the elbows lightly against the body. You can use either the left or the right eye to look through the finder (Figs. 8 and 9).





This is the position for horizontal shots with the CONTAFLEX.

For upright pictures turn the camera through 90 degrees, and press the upper end gently against the forehead with the

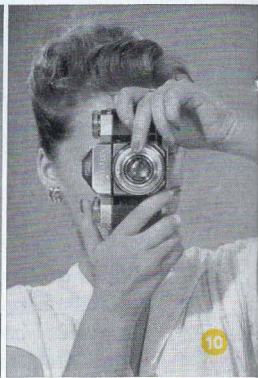
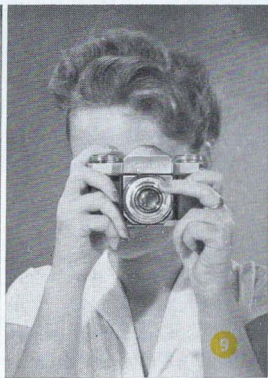

left hand. The second finger again operates the focusing mount (1). The right hand supports the camera from underneath, with the thumb on the release button (14). See Figs. 10 and 11.

Alternatively, you can take upright shots with the right hand end of the camera on top (Figs. 12 and 13). In this case the right index finger operates the release button (14), and the second finger of the

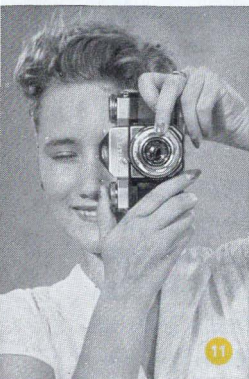

right hand the focusing mount (1). Use the left hand to support the CONTAFLEX from below. The illustrations on these pages show the various ways of holding the camera; so select the one that suits you best.



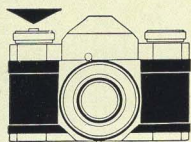
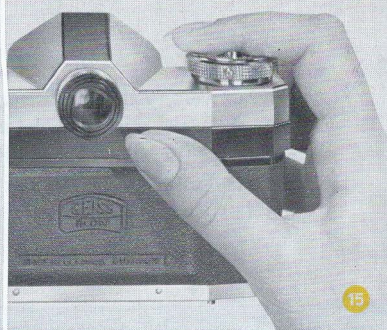
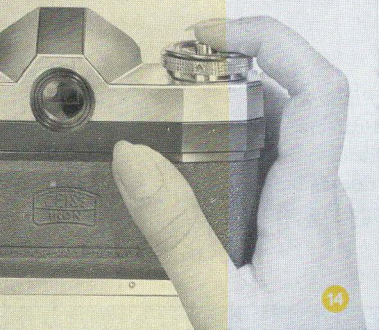

### *Releasing*

To release the shutter, press the release button (14). Use either the tip of the index finger (Fig. 14) or the first joint of the finger (Fig. 15), squeezing it downwards. This method of releasing is specially recommended, as experience has shown that it is least liable to cause camera shake. If by any chance the winding knob (12) was not wound to its fullest extent, thus advancing the film only part of the way, the shutter will not open when you press the release. This prevents double exposures.

## SPECIAL FEATURES OF THE CONTAFLEX I

### *The Finder*

The finder image is only visible after advancing the film and tensioning the shutter by the winding knob (12). This at the same time pushes down the mirror inside the camera; you know at a glance whether the camera is ready to shoot.

As long as you can see the large bright finder image, the lens aperture automatically remains fully open. This permits comfortable and accurate focusing. On pressing the release button the spring-loaded iris jumps to its pre-selected setting just before the shutter uncovers the film. The CONTAFLEX is the first camera to utilize this system. The finder always shows the correct field of view absolutely without any parallax error, even with the lens attachments or for close-ups with supplementary lenses. You can easily

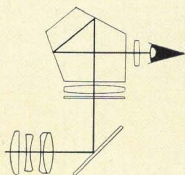



"follow" moving subjects with the camera, for you see the image at eye-level, upright, and the right way round. The black eye-piece mount (20) unscrews and will take suitable correction lenses (Order No. 902) to compensate for defects of vision. Even if you normally wear spectacles you can therefore observe the field of view and the rangefinder without glasses.

### *Zone Focusing*

To save time in focusing action subjects, a zone focus setting is provided. Set the aperture to the red figure 8 and the distance to 20 feet, also marked in red (Fig. 16). Everything from 9 feet to infinity will now be sharp. According to the lighting conditions, set the shutter to  $1/30$ ,  $1/60$ , or  $1/125$  second.

Another useful way of dealing with action subjects is as follows. For instance, if you want to get a shot of



children at play, set the aperture and shutter speed, and focus the lens at the most suitable distance. Now watch the view in the finder, and approach the subject until the two halves of the image in the rangefinder field coincide, or the picture is sharp on the ground glass ring. Then just check the view once more, and release.



### *Exposures from a Tripod*

The CONTAFLEX can be mounted on a tripod (Fig. 17) by means of the tripod bush (21). A ball-and-socket head or similar tripod head is required for upright photographs. To avoid camera shake, use a cable release (see page 37); this screws into the threaded socket in the release button (14). Always make exposures at shutter speeds slower than  $1/30$  second and time exposures from a tripod or other solid support.

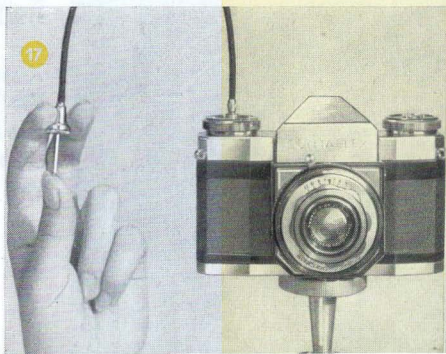

## *Flash Shots and the Self-Timer*

The speed-synchronized Synchro-Compur shutter model MXV can be connected to any flash gun. The synchronizing lever (10) has three settings (Fig. 18).

*With the lever set to X* the shutter closes the firing circuit at the instant when the blades are fully open. This is the correct setting for electronic flash units.

*With the lever set to M* the shutter closes the firing circuit before the blades are open; the delay corresponds to the firing delay of most flash bulbs. The M-setting therefore synchronizes flash bulbs up to the fastest shutter speeds.

*Setting the lever to V* brings the self-timer into action. On pressing the release button (14) the mirror moves out of the way and the iris jumps to its pre-selected aperture. The selftimer mechanism then takes about 8 seconds to run down, after which it automatically releases the shutter at the set speed. The self-timer

will not work with time exposures (with the shutter set to B). With the self-timer in operation, the shutter will synchronize flash units in the same way as at the X-setting. **Always tension the shutter by winding the knob (12) before you set the synchronizing lever to V.**

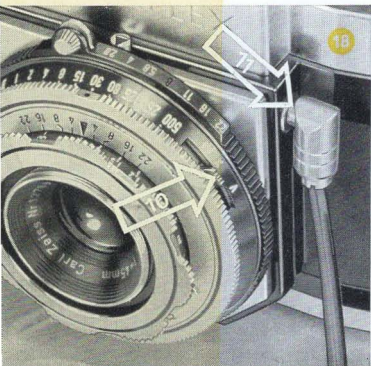



To take a flash shot, move the synchronizing lever (10) to the required setting. Plug the cable from the flash unit into the flash socket (11) on the camera (Fig. 18), and insert the flash bulb. Pressing the release button (14) fires the flash bulb in synchronization with the shutter, or sets off the self-timer mechanism. The table below shows the shutter speeds suitable for the different types of flash at the M-, X-, and V-setting of the synchronizing lever.

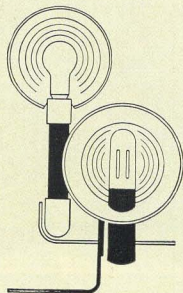

Flash	Synchronizing Lever Set To	
	X or V	M
Osram XM 1, S O XM 1B, S OB XP XO S 2	1-1/30	1/60-1/500
	1-1/30	1/60-1/125
	1-1/60	-
	1-1/30	-
	1-1/15	1/30-1/500
	1-1/15	1/30-1/500
Philips Pf 1, Pf 3, Pf 14, Pf 25, Pf 60 Pf 100	1-1/30	1/60-1/500
	1-1/15	1/30-1/60
General Electric No. 5, No. 11, No. 22 SM No. 50	1-1/30	1/60-1/500
	1-1/125	-
	1-1/15	1/30-1/60
	1-1/15	1/30-1/60
Sylvania Bantam 8, 0, 2, 25C, Press 40 Press 2B, 25, 25B, 40B Press SF Press 3, 3B	1-1/30	1/60-1/500
	1-1/30	1/60-1/125
	1-1/125	-
	1-1/15	1/30-1/60
	1-1/15	1/30-1/60
Electronic Flash Units	1-1/500	-

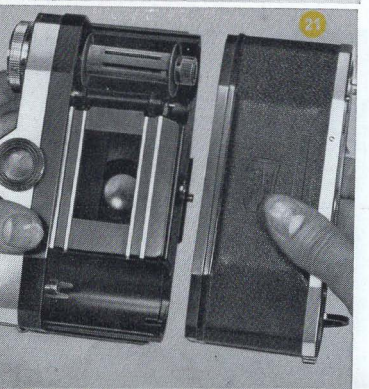
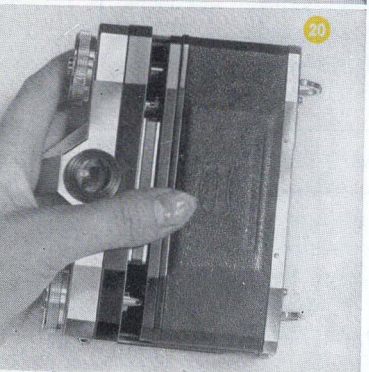
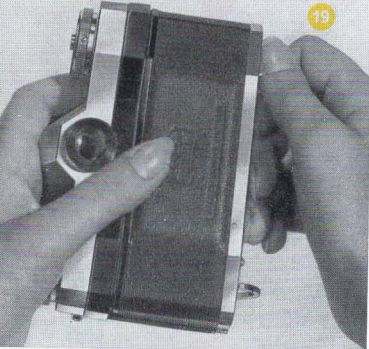

## LOADING AND

### *Opening the Camera*

Hold the **CONTAFLEX** in your left hand with the lens pointing downwards, and the finder housing against the palm of the hand (Fig. 19). Place the thumb on the camera back (18). Lift the locking keys (19) in the bottom of the **CONTAFLEX** with the right hand and turn them to the right or left. Slightly push down the camera back with the left thumb (Fig. 20), and lift off with the right hand (Fig. 21).

### *Loading*

First introduce the beginning of the film into the long slot and hook it to the small nose (fig. 22). When using bulk film the beginning of the film must for this purpose be cut obliquely (fig. 23).

## UNLOADING

Then insert the cassette in the lower chamber so that the slotted shaft of the rewind knob engages the core of the cassette spool. Insert the take-up spool in the upper chamber (Fig. 24). Now wind the film up on the take-up spool until the transport sprocket engages the film perforations at both sides (Fig. 25). Hold the film in contact with the transport sprocket with the left thumb, place the camera back into its grooves from above (Fig. 26), and slide it up to close the camera completely. Turn the locking keys (19) in the bottom of the *CONTAFLEX*, and fold them down. With the back in position, the keys can only be folded down when the back is properly pushed home. Finally wind the knob (12) and release

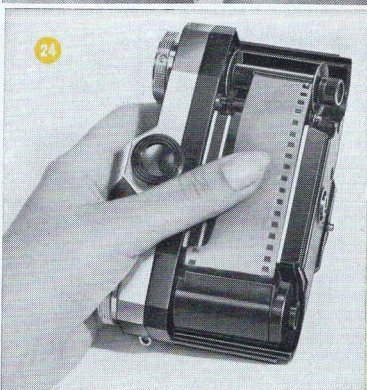
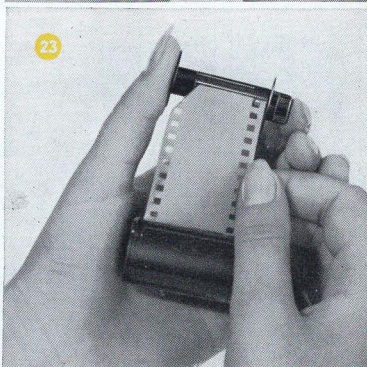
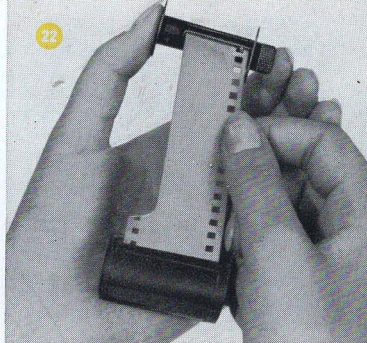

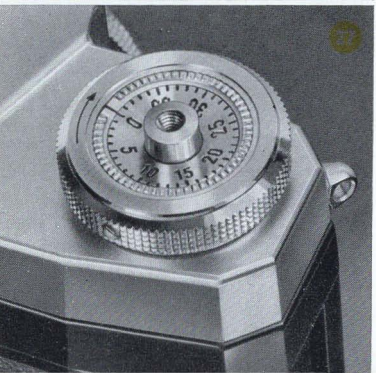
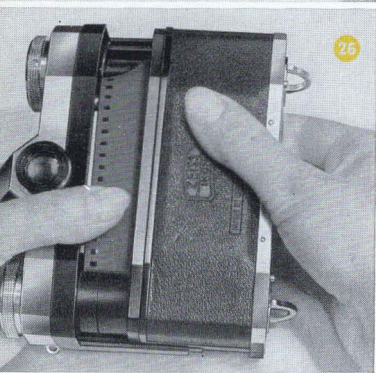
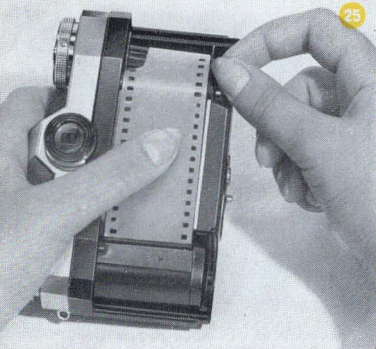

the shutter twice to wind up the exposed film leader on to the take-up spool and to bring a length of unexposed film into position behind the film aperture.

During film transport the rewind knob (15) must rotate in the opposite direction to the arrow engraved on it. This indicates that the film is advancing properly. When using bulk film or 20-exposure cassettes the film may unroll itself inside the cassette, and the rewind knob will not rotate for the first few frames. In that case turn the rewind knob in the direction of the arrow until you feel some resistance to show that the film has been loaded correctly. This is also a way of telling whether there is any film in the camera at all.

Turn the milled film counter disc (13) to No. 0 (you can turn it in either direction), and the CONTAFLEX is ready for the first exposure (Fig. 27).



### *The Special Cassettes*

The CONTAFLEX also takes the same special cassettes as the CONTAX. You can work from the cassette to the take-up spool, or from cassette to cassette. The CONTAX cassette consists of two shells and a centre spool. To open it, press the locking button, turn the inner and outer shells against each other until their slots coincide, and pull apart (Fig. 28).

The cassette will take darkroom refills, daylight refills, or bulk film. When working with a take-up cassette the film must only be hooked on the spool of the feed cassette. If the film is to be rewound, the end should be firmly fixed to the feed spool. In that case push the narrow tongue through the short slot of the core so that it protrudes from the long slot. Now introduce the tongue once more into the small slot, retain it with your thumb and pull the film taut (Fig. 29). Then wind the film up on the spool.



28

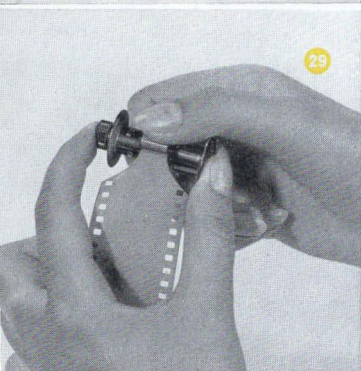

29

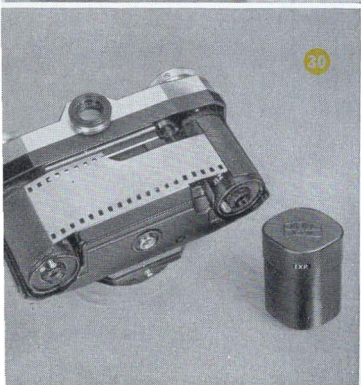

30

Insert the full spool, with the milled spool knob in front, into the inner shell of the cassette, and push the outer shell over it. The film end should then protrude through the superimposed slots of the shells. Turn the inner and outer shells against each other until they lock and the word "zu" appears. When working with two cassettes (Fig. 30) there is no need to rewind the film. It can also be unloaded after any number of exposures together with the take-up cassette in broad daylight. But advance the film by two frames before opening the camera. This two-cassette system is specially useful if you want to change over frequently from black-and-white film to colour and vice versa. When inserting the cassettes in the feed or take-up chambers make sure that the locating pegs of the

cassettes engage in the corresponding grooves of the camera body. Turning the locking keys of the camera back automatically opens or closes the cassettes.

Every cassette is supplied in a special container. The lid carries a small window and can be fitted in two positions. When storing an exposed cassette in the container, fit the lid in such a way that the marking "Exp." is visible through the window.



### *The Film Indicator*

To show the type of film loaded into the CONTAFLEX I, the rewind knob (15) carries a film indicator. This can be set to daylight type colour film, artificial light type colour film, or black-and-white film, and the appropriate speed of each. To adjust the indicator, turn the inner disc (16) so that the

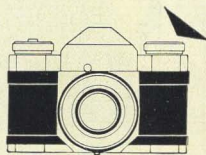

31

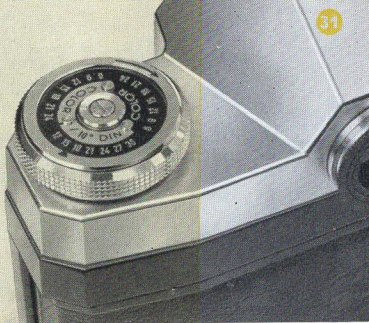

index mark of the outer ring points to the type and speed of the film in the camera (Fig. 31).

### *Unloading*

If the camera is loaded with a standard film cassette, the film must be rewound before unloading. Depress the reversing button (17) underneath the camera, and rewind the film into the feed cassette by turning the rewind knob (15) in the direction of the arrow (Fig. 32). When a take-up cassette is used in place of the take-up spool, there is no need to rewind the film. In that case the film may also be changed after any number of exposures in broad daylight; just advance the film and release the shutter twice after

the last exposure in order to get the last exposed frame into the take-up cassette.

32



Then open the **CONTA-FLEX** as described on page 26 and take out the standard or special



cassette with the exposed film. Be sure to remove immediately from the camera any fragments that might have come off the film.

## ACCESSORIES

### *The Ever-Ready Case*

The practical ever-ready case (Fig. 33) protects the CONTAFLEX against damage. The camera is held in the case by a screw and need not be removed for picture taking. The case will also hold the CONTAFLEX with a filter, the accessory shoe, and the lens attachment holder. The lid of the case is pivoted and swings out of the way when taking upright shots. The upper part of the case will also accommodate two filters (without their container).

### *Carrying Strap*

To enable you to carry the CONTAFLEX round your neck without the ever-ready case, a carrying strap is available. This is fitted with safety hooks to hook into the two eyelets (22).



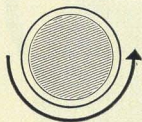
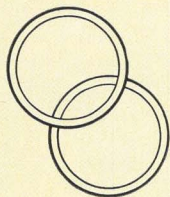

### *Filters*

ZEISS IKON precision filters are available for special effects in yellow, yellow-green, orange, red, IKOLOR-A and -B and as ultra-violet filters. They screw into the lens mount (27 mm diameter) or slip over the lens attachment TELESKOP (55 mm diameter, see page 37). With filters the exposure must be increased by the corresponding filter factor which is engraved on the mount of all ZEISS IKON precision filters.

### *The CONTAPOL Polarizing Filter*

The CONTAPOL polarizing filter, screwed into the lens mount, eliminates disturbing reflections from shiny surfaces of the subject. You can observe the effect of the polarizing filter in the finder. When rotating the CONTAPOL take care not to change the distance setting accidentally. A lens hood or supplementary lens or both can be mounted on top of the CONTAPOL. For further details see the instructions enclosed with the polarizing filter.

### *PROXAR Lenses for Close-ups*

The CONTAFLEX lens focuses down to a distance of 3 feet. For nearer subjects coated ZEISS PROXAR supplementary lenses are available which slip over the camera lens (mount diameter 28.5 mm). The finder will still show the correct field of view without any parallax error, and the CONTAFLEX can be focused in the same way as described on page 11. There are four PROXAR lenses with focal lengths of  $39\frac{1}{2}$  inches (100 cm) for subjects down to  $19\frac{3}{4}$  inches (50 cm),  $19\frac{3}{4}$  inches (50 cm) for subjects between  $19\frac{3}{4}$  and  $11\frac{3}{4}$  inches (50 to 30 cm),  $11\frac{3}{4}$  inches (30 cm) for subjects down to 9 inches (22.5 cm), and 8 inches (20 cm) for distances down to  $6\frac{1}{4}$  inches (16 cm). The table on page 36 gives details of the subject distances, the scale of reproduction, and the field covered. The distances are measured from the front edge of the supplementary lens mount to the subject. An aperture of  $f/8$  usually yields sufficient depth of field.

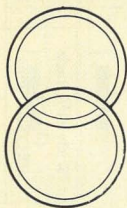

**Focusing Table for PROXAR Supplementary Lenses**

	Lens set to (feet)	Subject Distance	Reduction 1:	Field size
With 39 <sup>1</sup> / <sub>2</sub> inch (100 cm) PROXAR lens	inf.	3' 3 <sup>1</sup> / <sub>2</sub> "	21	1' 7" × 2' 5"
	20	2' 9 <sup>1</sup> / <sub>2</sub> "	18	1' 4 <sup>1</sup> / <sub>4</sub> " × 2' 3 <sup>1</sup> / <sub>4</sub> "
	10	2' 5 <sup>1</sup> / <sub>2</sub> "	16	1' 2 <sup>1</sup> / <sub>2</sub> " × 1' 10"
	6	2' 1 <sup>1</sup> / <sub>2</sub> "	13	11 <sup>3</sup> / <sub>4</sub> " × 1' 6"
	4	1' 9"	11.5	10 <sup>1</sup> / <sub>2</sub> " × 1' 4"
	3	1' 6 <sup>1</sup> / <sub>2</sub> "	9.5	8 <sup>1</sup> / <sub>2</sub> " × 1' 1"
With 19 <sup>3</sup> / <sub>4</sub> inch (50 cm) PROXAR lens	inf.	1' 7 <sup>3</sup> / <sub>4</sub> "	11.1	10 <sup>3</sup> / <sub>4</sub> " × 1' 3 <sup>1</sup> / <sub>4</sub> "
	20	1' 6"	10	9" × 1' 1 <sup>3</sup> / <sub>4</sub> "
	10	1' 5"	9	8" × 1' 1 <sup>1</sup> / <sub>2</sub> "
	6	1' 3 <sup>1</sup> / <sub>2</sub> "	8	7 <sup>1</sup> / <sub>4</sub> " × 11"
	4	1' 1 <sup>1</sup> / <sub>2</sub> "	7.5	6 <sup>3</sup> / <sub>4</sub> " × 10 <sup>1</sup> / <sub>4</sub> "
	3	1' 3 <sup>1</sup> / <sub>4</sub> "	7	6 <sup>1</sup> / <sub>4</sub> " × 9 <sup>1</sup> / <sub>2</sub> "
With 11 <sup>3</sup> / <sub>4</sub> inch (30 cm) PROXAR lens	inf.	1' 1 <sup>5</sup> / <sub>16</sub> "	7.38	6 <sup>11</sup> / <sub>16</sub> " × 10 <sup>1</sup> / <sub>8</sub> "
	20	1' 3 <sup>3</sup> / <sub>8</sub> "	6.96	6 <sup>1</sup> / <sub>4</sub> " × 9 <sup>1</sup> / <sub>2</sub> "
	10	11 <sup>13</sup> / <sub>16</sub> "	6.65	6" × 9 <sup>3</sup> / <sub>16</sub> "
	6	11 <sup>1</sup> / <sub>8</sub> "	6.19	5 <sup>9</sup> / <sub>16</sub> " × 8 <sup>3</sup> / <sub>16</sub> "
	4	10 <sup>1</sup> / <sub>4</sub> "	5.69	5 <sup>1</sup> / <sub>8</sub> " × 7 <sup>13</sup> / <sub>16</sub> "
	3	9 <sup>1</sup> / <sub>2</sub> "	5.24	4 <sup>3</sup> / <sub>4</sub> " × 7 <sup>3</sup> / <sub>16</sub> "
With 8 inch (20 cm) PROXAR lens	inf.	7 <sup>7</sup> / <sub>8</sub> "	4.43	4" × 6 <sup>3</sup> / <sub>32</sub> "
	20	7 <sup>21</sup> / <sub>32</sub> "	4.30	3 <sup>7</sup> / <sub>8</sub> " × 5 <sup>13</sup> / <sub>16</sub> "
	10	7 <sup>13</sup> / <sub>32</sub> "	4.16	3 <sup>25</sup> / <sub>32</sub> " × 5 <sup>3</sup> / <sub>4</sub> "
	6	7 <sup>3</sup> / <sub>32</sub> "	3.97	3 <sup>9</sup> / <sub>16</sub> " × 5 <sup>15</sup> / <sub>32</sub> "
	4	6 <sup>23</sup> / <sub>32</sub> "	3.75	3 <sup>3</sup> / <sub>8</sub> " × 5 <sup>5</sup> / <sub>32</sub> "
	3	6 <sup>3</sup> / <sub>8</sub> "	3.55	3 <sup>7</sup> / <sub>32</sub> " × 4 <sup>7</sup> / <sub>8</sub> "

The field size is calculated for a useful image area of 23×35 mm

### *Lens Attachments*

The ZEISS IKON TELESKOP increases the effective focal length of the CONTAFLEX lens 1.7 times. Like in a telescope, the subject is brought near and recorded in large size. The stereo attachment STERITAR-A extends the scope of the CONTAFLEX to cover the interesting field of stereo photography. Both attachments are simply mounted in front of the lens with the aid of the attachment holder. No accessory finders are required.

### *The Lens Hood*

This prevents flare and veiling in against-the-light shots. In bad weather it also protects the lens against rain or snow. The ZEISS IKON lens hood can also be mounted on top of filters or PROXAR lenses. The mount diameter required is 28.5 mm, or 55 mm for use with the TELESKOP screw mount.

### *The Cable Release*

At slow shutter speeds and for time exposures a cable release is advisable (see Fig. 17 on page 23). This screws into the threaded socket in the release button (14). The ZEISS IKON cable release is fitted with a lock to keep the shutter open for long time exposures with the shutter set to "B".

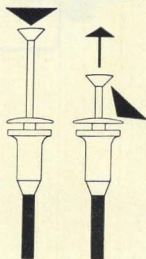
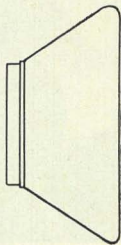

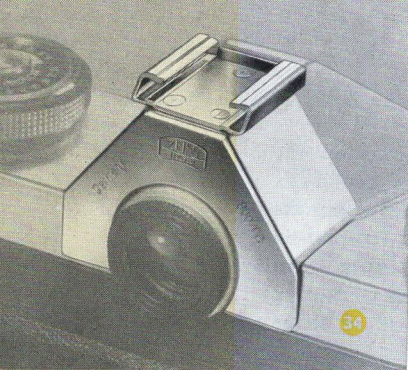

### *The Accessory Shoe*

An accessory shoe can be fixed to the CONTAFLEX for mounting various accessories on the camera. Unscrew the black mount of the finder eyepiece (20), place the accessory shoe over the eyepiece opening, and screw the

black mount back again to hold the shoe in place (Fig. 34).

### *Colour Photography*

The outstanding quality and colour correction of the ZEISS TESSAR lens ensure particularly fine colour shots with the CONTAFLEX I. Since colour films have a very limited exposure latitude as compared with black-and-white film, the exposure must be really accurate in colour photography. There the ZEISS IKON IKOPHOT RAPID photo-electric exposure meter (see illustration on page 15) is very useful. Ask your photo dealer for a detailed free leaflet.

### *Copying*

A special tripod head is available for using the CONTAFLEX with the CONTAX

copying outfits. To make focusing easier, a rightangle viewing telescope can be screwed over the finder eyepiece.

### *Flash Shots*

The ZEISS IKON IKOBLITZ 0 and folding IKOBLITZ flash guns are specially suitable for flash shots with the CONTAFLEX. Preferably use the ZEISS IKON right-angle plug (see Fig. 18 on page 24) to connect the flash units to the flash socket (11) of the camera.

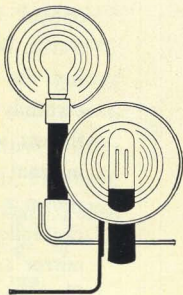

### *Artificial Light Exposures*

The MOVILUM universal lighting unit provides artificial light of any required intensity (Fig. 35). It can be fitted with two, four, or even six reflectors. As the lamps are individually adjustable, all kinds of lighting effects are possible.

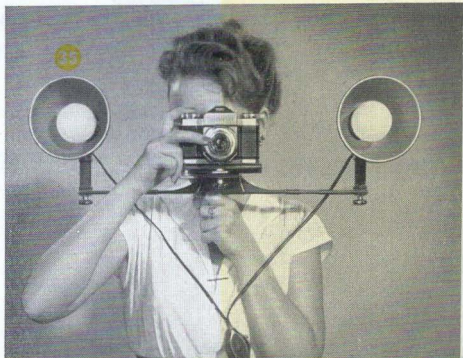

## *The Inside Story*

You will probably want to know more about what goes on inside your CONTAFLEX, and how this masterpiece of optical and mechanical precision engineering really works. But please don't satisfy your curiosity by attacking the camera with a screw driver or pliers — it certainly won't do your CONTAFLEX any good! Nevertheless we should like to give you some idea of the internal anatomy of your camera, and have therefore shown a cross-section of it on the last page. There you can follow the path of the light from the lens via the mirror and finder system to the eye. The letters of the illustration indicate the following details:

- a *Winding knob with film counter and release button*
- b *Pentaprism*
- c *Finder eyepiece*
- d *Condenser lens*
- e *Fresnel field lens with ground glass screen ring and split-image rangefinder*
- f *Mirror*
- g *Capping plate*
- b *Film track*
- i *Film pressure plate*
- k *Removable back*
- l *Tripod bush*
- m *Spring-loaded pre-selector iris*
- n *Diaphragm shutter*
- o *1<sup>3</sup>/<sub>4</sub> inch (45 mm) ZEISS TESSAR f 2.8 lens*



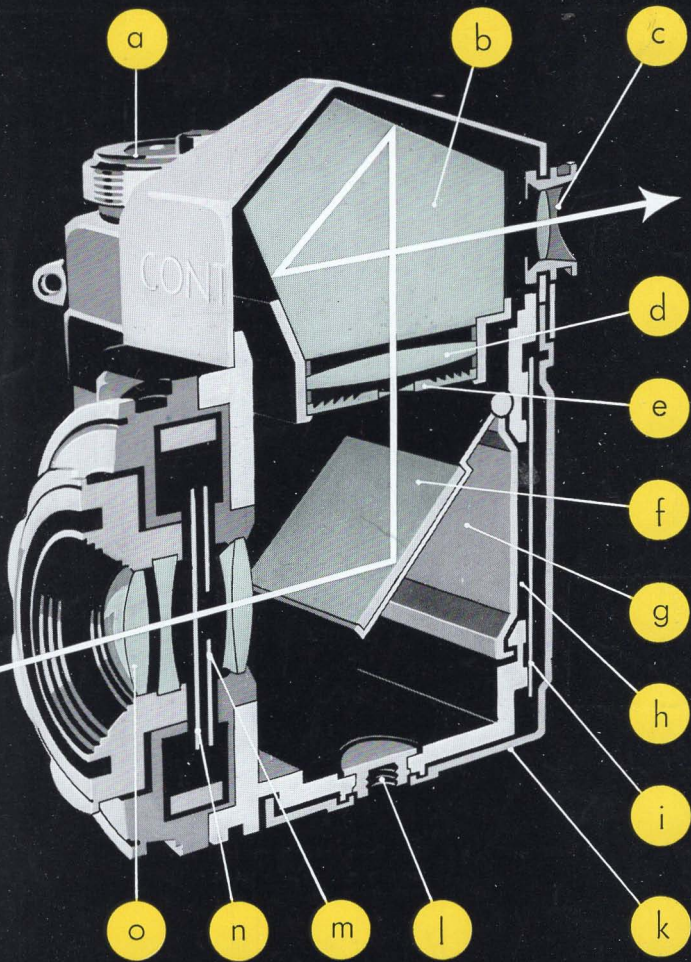

## THE CONTAFLEX I CONTROLS

- 11 Flash socket
- 12 Winding knob
- 13 Film counter disc
- 14 Release button
- 15 Rewind knob

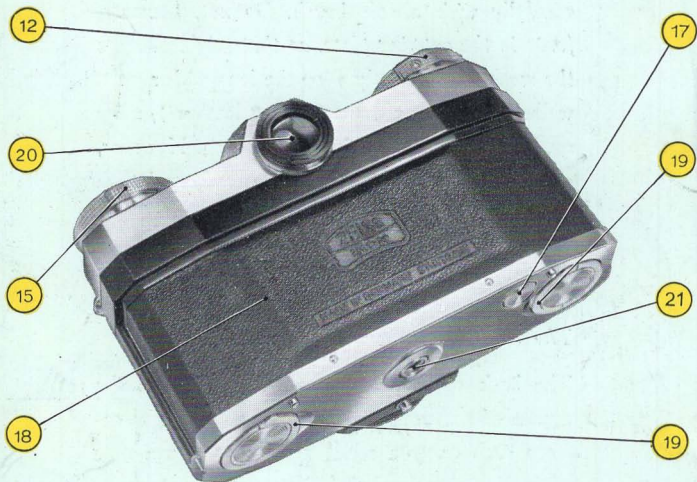

- 16 Film indicator
- 17 Reversing button
- 18 Removable camera back
- 19 Locking keys of camera back
- 20 Finder eyepiece
- 21 Tripod bush
- 22 Eyelets for carrying strap

The numbers refer partly to Fig. 1 on page 3 of the front cover

### *Care of the CONTAFLEX*

From time to time clean the film track, the cassette chambers, and the back of the CONTAFLEX carefully with a soft brush. *Do not, however, force in the capping plate, as that might damage the mechanism.* Gently wipe the lens with a soft, wellwashed piece of linen (but not leather!); after removing any dust with a soft brush. However, clean the lens only if it is really necessary. Polish the chromium plated outside fittings of the camera occasionally with a soft linen rag.

### *The Serial number*

The back of every CONTAFLEX, as well as the mount of the ZEISS TESSAR lens built into the camera each carry a serial number. Make a note of both these numbers of your CONTAFLEX, as they may be of material help in tracing the camera if lost or stolen.

*Technical improvements may result in slight departures from this description in the details of the camera.*

ZEISS IKON AG. STUTTGART

