

CODE NO. ITEM
3-31101-21 Canon AZ 318M w/lens 10-30mm
f/1.8 in case

Canon

AUTO ZOOM 318M



The Compact Super 8 with a Big Handful of Features



- **Type:** 8mm movie camera using Super 8 film cartridges
- **Picture Size:** 5.4x4.0mm
- **Lens:** 10-30mm f/1.8 zoom, with 3:1 zoom ratio; 11 elements in 9 groups
- **Macro-Filming Mechanism:** Close-up filming is possible by setting the zooming ring at the "M" mark. Camera-to-subject distance is 22.5cm (8⁷/₈"') from film-plane indicator. Subject field at this distance is 10.4x7.5cm (4¹/₈"'x2¹⁵/₁₆"')
- **Focusing:** by estimation; distance scale and two snapshot marks indicated
- **EE Mechanism:** automatic aperture setting coupled to film speed and filming speed
- **Exposure Meter:** through-the-lens metering system using CdS photocell
- **Metering Range:** ASA 160, f/1.8, 18fps to ASA 25, f/22, 18fps
- **Film Speeds:** Automatically set with insertion of film cartridge.
tungsten-type film: ASA 40 or 160
daylight-type film: ASA 25 or 100
- **CCA Filter:** built in Color Conversion A (CCA) filter makes

possible the use of tungsten-type film under daylight conditions; under tungsten light conditions, cancel the CCA filter with CCA Filter Cancellation Adapter

- **Filming Speeds:** 18fps and single-frame
- **Film Drive:** by high performance micromotor
- **Zooming:** power drive zooming coupled to film drive (zooming by power possible only while shutter is being released); zooming speed, approx. 5.5 sec. manually operated zooming possible
- **Power Source:** three 1.5V penlight (AA) batteries, used in common for film drive and metering; under normal temperature conditions, 7 cartridges of film can be shot using manganese batteries, 14 can be shot using alkaline batteries
- **Footage Counter:** counts up to 50 ft. Automatically resets when the cartridge is removed.
- **Release Socket:** for cable release used for single-frame exposures
- **Grip:** Folding-type trigger grip prevents accidental shutter release.
- **Size:** 172x80.6x60mm (6³/₄"'x3³/₁₆"'x2³/₈"')
- **Weight:** 470g (1 lb. 9⁹/₁₆ oz.) With battery

SELLING POINTS

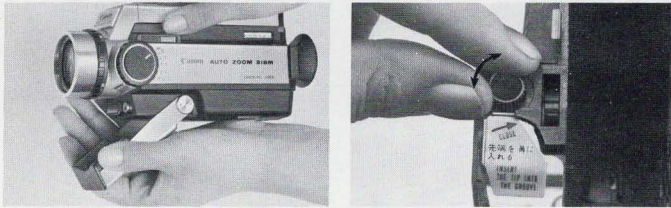

EXTREMELY COMPACT AND LIGHT WEIGHT

- a. For the greatest in portability, the Canon AZ 318M is the most compact Super 8 camera Canon makes. With its folding trigger grip, it can be carried or stored almost anywhere, making it an ideal Super 8 for traveling.
- b. The trigger grip features a special shutter release guard to prevent accidental shooting or battery drain.

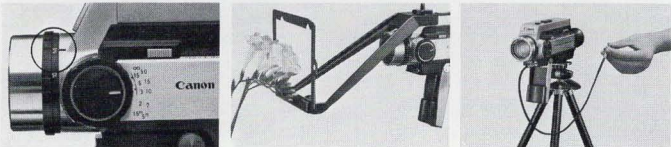

CONVENIENT OPERATION FOR CLOSE-UP FILMING

- a. Macro filming is simplified with the 318M by using the optional Macro Frame, which outlines the subject area for the ultimate in fixed-distance photography of small objects. By simply turning the zooming ring, fixed-focus close-up photography can be done as close as 22.5cm (8⁷/₈"') from the film plane.

SINGLE-FRAME FILMING

- a. Using Canon Release 30 or 50, single-frame filming is possible for animation or titling requirements, or for "time lapse" photography of such subjects as blooming flowers, etc.

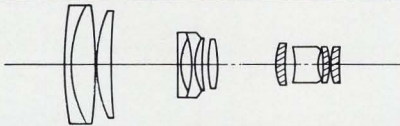

FAST, SHARP CANON ZOOM LENS (10-30mm)

- a. The 318's new 3:1 zoom lens is especially compact, sharp and contrasty. Its exclusive Canon Spectra Coating insures the highest in optical excellence.

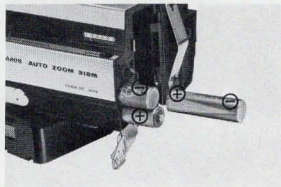

COMMON POWER SOURCE

- a. Three penlight batteries control the 318's metering, film drive and zooming. This advantage prevents gradual deterioration of performance due to failure of separate power supplies. When the three cells fail, all functions stop uniformly, preventing waste of film.

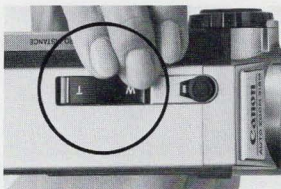

AUTOMATIC POWER OR MANUAL ZOOMING

- a. Smooth power zooming from 10 to 30mm. This type of smooth operation is essential for professional-looking movies. For special applications, manual zooming is possible.

Under exposure warning mark

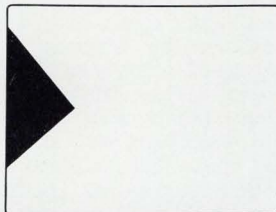

SINGLE-LENS REFLEX VIEWING WITH WARNING MARKS

- a. Since the user sees through the taking lens, he will always know just what's being filmed. In the viewfinder a red under exposure warning mark tells the user when to use additional lighting or a Canon Neutral Density filter for proper exposure.
- b. A yellow mark inside the viewfinder indicates to the user that the camera's macro shooting mode is in use.

Long distance snapshot mark

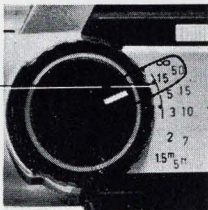

Close distance snapshot mark

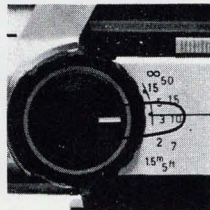

SIMPLE, FAST FOCUSING WITH TWO SNAPSHOT MARKS

- a. Since depth-of-field is great with the AZ 318M, the 3.5m and 14m distance positions on the distance scale will prove excellent focus for the majority of subjects.



Screw the CCA Filter Cancellation Adapter



SHOOTING WITH ARTIFICIAL LIGHT

- a. When using a lighting unit capable of screwing directly into the CCA Filter Cancellation Adapter Socket, it is not necessary to use the CCA Filter Cancellation Adapter.

NOMENCLATURE

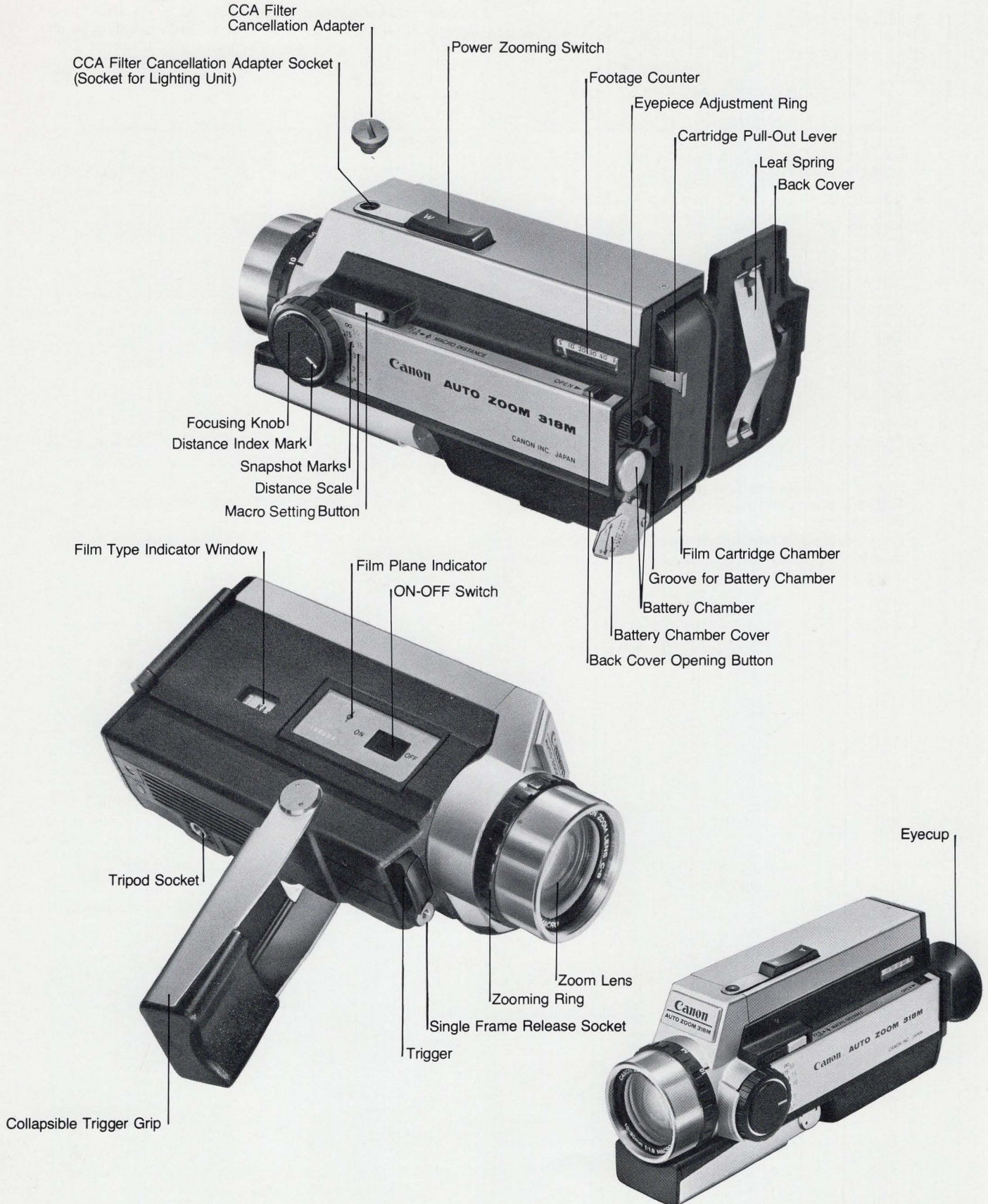

ACCESSORIES

| CODE NO. | DESCRIPTION |
|------------|---|
| 5-39111-00 | Chest Pod |
| 4-26401-00 | Macro Frame for AZ318M |
| 5-63061-00 | Release 30 |
| 5-63062-00 | Release 50 |
| 4-20601-20 | Copystand 4 |
| 33-8621 | Socket Cover for Filter Cancellation Adaptor for AZ318M |
| 33-8804 | Filter Cancellation Adaptor AZ318M |
| 33-8622 | Lens Cap 45mm for AZ318M |
| 4-60881-00 | Carrying Case for AZ318M |
| 5-61021-00 | Wrist Strap 2 |
| 4-10486-21 | Cine Projector S-400 |

PLEASE NOTE: For further information on Canon Super-8 accessories, please refer to the last page in this section.

For information on filters available for Canon Super 8 cameras, please see section 2 of the Sales Guide.