

## THE PHOTOMACROGRAPHY GROUP

- Most versatile and comprehensive photomacrographic system
- Permits photography at magnifications up to 16.5X
- Includes a macro lens designed specifically for 1-to-1 reproduction, ideal for slide duplication (Olympus exclusive)
- Open-aperture exposure makes outdoor photomacrography convenient
- Can be used with OM Motor Drive 1, Winder 1 and Camera-Regulated Auto Flash 310
- Perfect for specialized indoor close-ups
- Ideal for reproducing photographs and documents
- OM-2's OTF (off-the-film) fully automatic exposure control compensates for bellows extensions, light loss, etc.

## PHOTOMACROGRAPHY GROUP

Designed for specialists in the field of photomacrography, this group includes Epi- and Trans-Illuminators for high-intensity and shadowless illumination, a set of four Zuiko Macro Lenses (for complete information, see Lens Group), plus a slide copier, bellows, stands, and a wide variety of holders, frames, lighting equipment, extension tubes, filters, and reflectors.

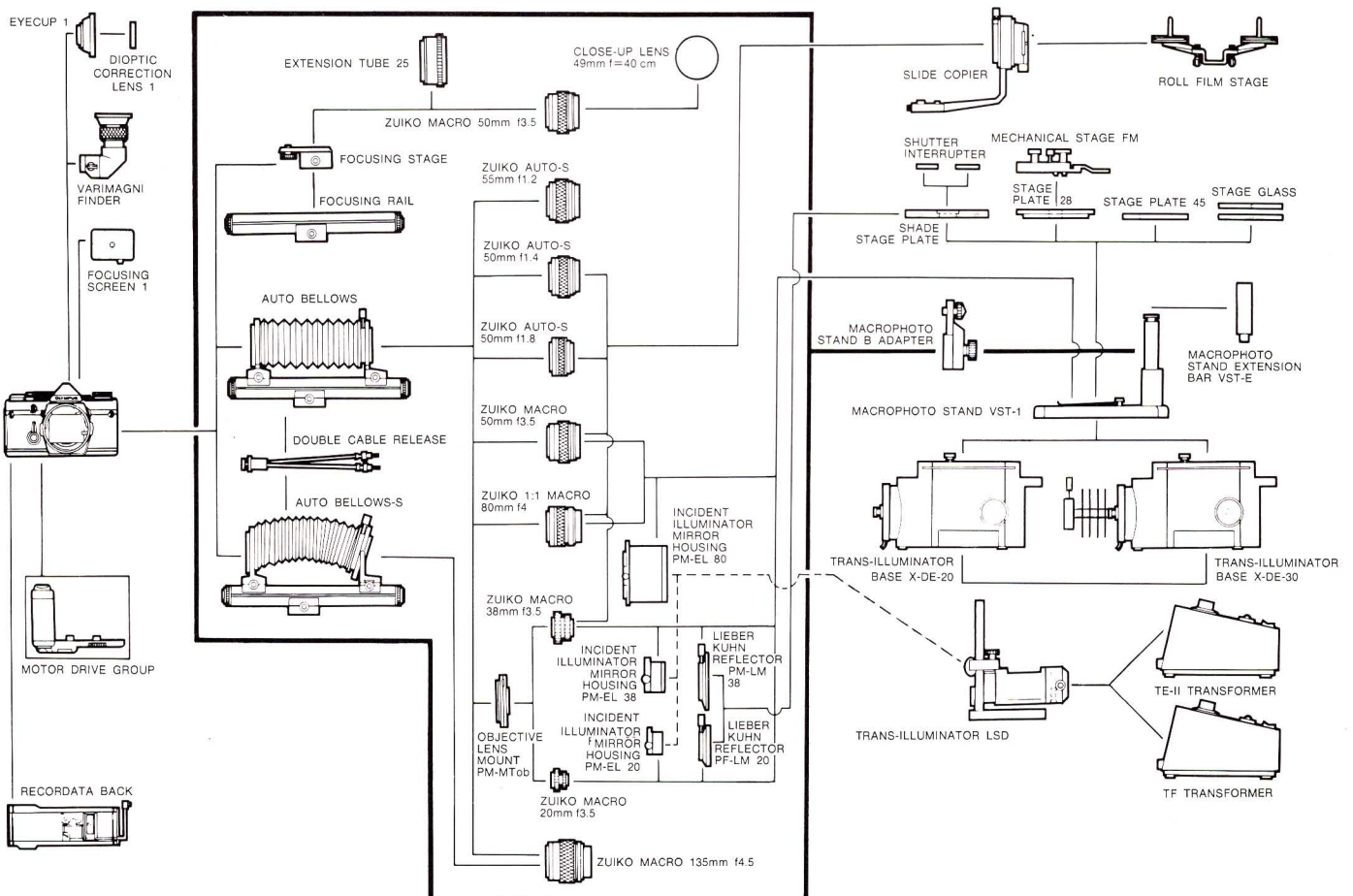
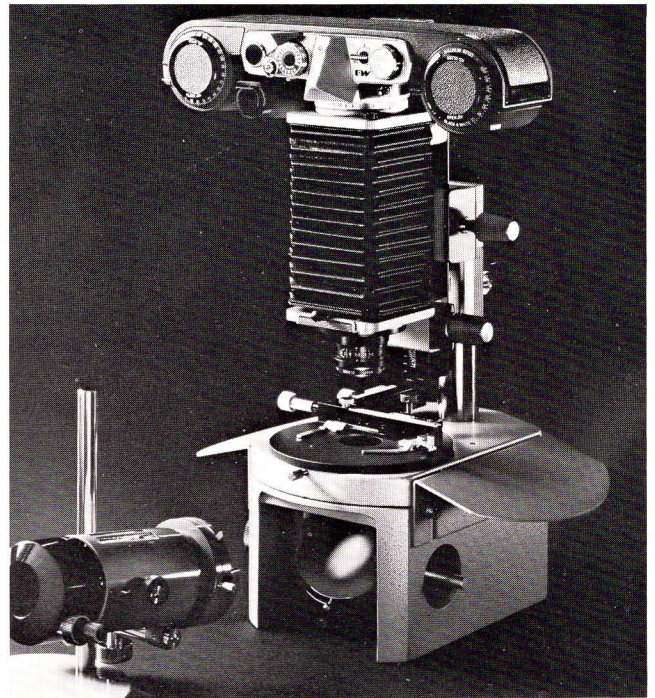

## SLIDE COPIER

For use with the Auto Bellows to copy transparencies in color or black and white. Provides a solid and optically correct platform for slide duplication. Slide or filmstrip is placed behind the detachable diffusion glass on the copier. The 1:1 Macro 80mm F4 lens is recommended for best results when using the Slide Copier, although the standard lenses and the Macro 50mm f3.5 are usable. When the standard f1.2 lens is used, Adapter Ring 55→49mm must be attached between lens and copier.

### ORDERING INFORMATION

**Slide Copier**  
Stock No. 104-111

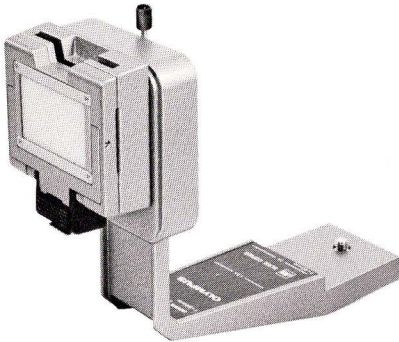

## ROLL FILM STAGE

Used with auto bellows and slide copier for duplicating from roll film.

### ORDERING INFORMATION

**Roll Film Stage**  
Stock No. 104-112

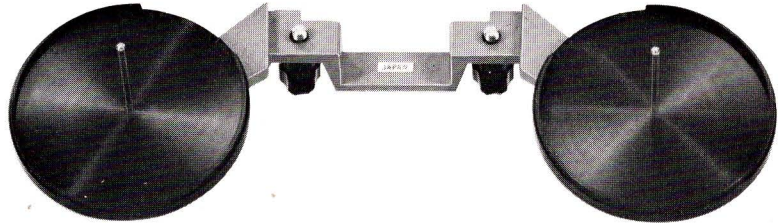

## OBJECTIVE LENS MOUNT PM-MT ob

This specially designed lens mount adapter is used to mount either 38mm f3.5 Zuiko Macro Lens or 20mm f3.5 Zuiko Macro Lens to the auto bellows.

**ORDERING INFORMATION**  
**Objective Lens Mount PM-MT ob**  
Stock No. 104-220



## PHOTOMACROGRAPHIC STAND VST-1

Designed for use with the trans-illuminator base for photographing with transmitted light. Comes with round frosted stage plate (black at back) for incident light and two retaining clips. Additional stage plates are available for virtually all forms of photomacrographic lighting needs.

**ORDERING INFORMATION**  
**Macrophoto Stand VST-1**  
Stock No. 104-120

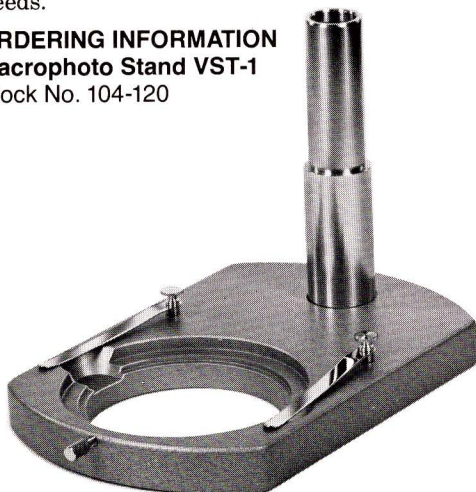

## PHOTOMACROGRAPHIC STAND EXTENSION BAR VST-E

Will extend the post of the Photomacrographic Stand VST-1 in cases where the post is not sufficiently long to provide desired lens to subject distance.

**ORDERING INFORMATION**  
**Photomacrographic Stand  
Extension Bar VST-E**  
Stock No. 104-121



## PHOTOMACROGRAPHIC STAND B ADAPTER

Designed to support bellows or focusing rail on Photomacrographic Stand VST-1.

**ORDERING INFORMATION**  
**Macrophoto Stand B Adapter**  
Stock No. 104-121



## AUTO BELLOWS

Complete unit consists of bellows, focusing rail and focusing tripod block. Auto Bellows is placed between camera body and lens providing required lens extension for photomacrographic work. With Double Cable Release, the diaphragm automatically stops down to preselected aperture at moment of exposure. Preset lever enables viewing depth of field prior to taking picture. Focusing and magnification can be adjusted independently for maximum versatility. Bellows extension scale is imprinted on rail. All OM System lenses (except 20mm, 38mm and 80mm photomacro lenses) can be used without affecting automatic stop down exposure mechanism. Generally photomacrographs at magnifications greater than life size should be taken with lens reversed. Auto Bellows provides removable lens mounting board enabling reversal of lens without removal of lens from the lens board. Screw-in type knobs lock bellows along rail for positive focusing and single knob provides for fine camera position adjustments without moving stable support.

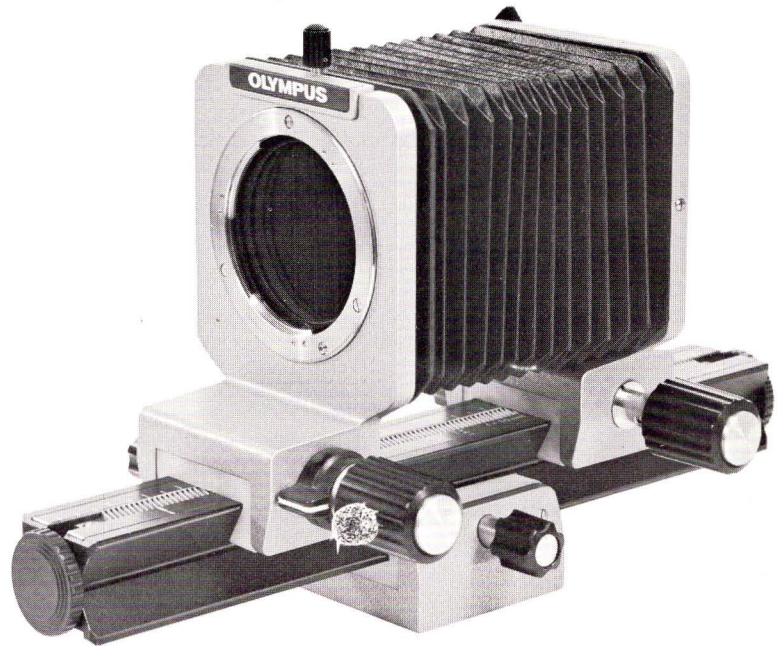

### ORDERING INFORMATION

#### Auto Bellows

Stock No. 104-100

## DOUBLE CABLE RELEASE

Used with Auto Bellows for synchronizing lens diaphragm operation with camera shutter release. Ring lock for long exposures is built-in.



### ORDERING INFORMATION

#### Double Cable Release

Stock No. 104-110

## FOCUSING RAIL

Specially designed to mount on tripod, copy stand or Photomacrographic Stand B Adapter. Single knob provides for fine camera position adjustments without moving screw-type stable support. Bellows extension scale imprinted on rail.

### ORDERING INFORMATION

#### Focusing Rail

Stock No. 104-113

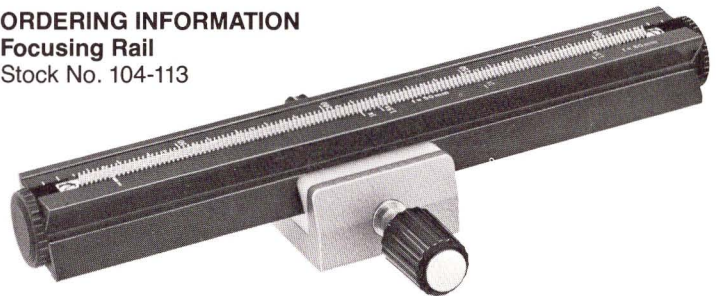

## FOCUSING STAGE

Allows mounting camera on focusing rail. Convenient means of shifting camera position back and forth or from left to right.



### ORDERING INFORMATION

#### Focusing Stage

Stock No. 104-114

## TRANS-ILLUMINATOR BASE X-DE

Designed to support Photomacrographic Stand VST-1 and reflect light from beneath the subject by a combination plano and concave mirror. Light source can be natural, but Trans-Illuminator LSD delivers best results. This type of lighting allows viewing the subject more clearly, and is particularly helpful with transparent subjects. Wooden handrests and a built-in 100-volt, 20- or 30-watt trans-illuminator.

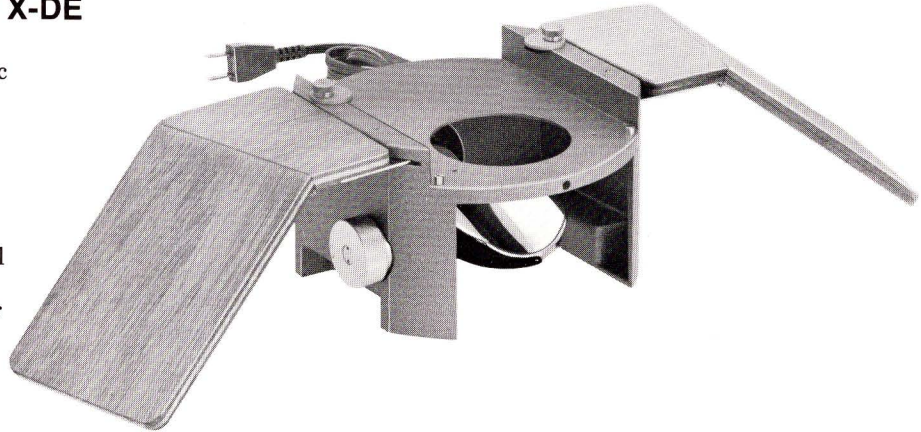

### ORDERING INFORMATION

**Trans-Illuminator Base X-DE (30 watt)**  
Stock No. 104-140

**Bulb for X-DE Illuminator (30 watt)**  
Stock No. 104-146

**Trans-Illuminator Base X-DE (20 watt)**  
Stock No. 104-141

**Bulb for X-DE Illuminator (20 watt)**  
Stock No. 104-145

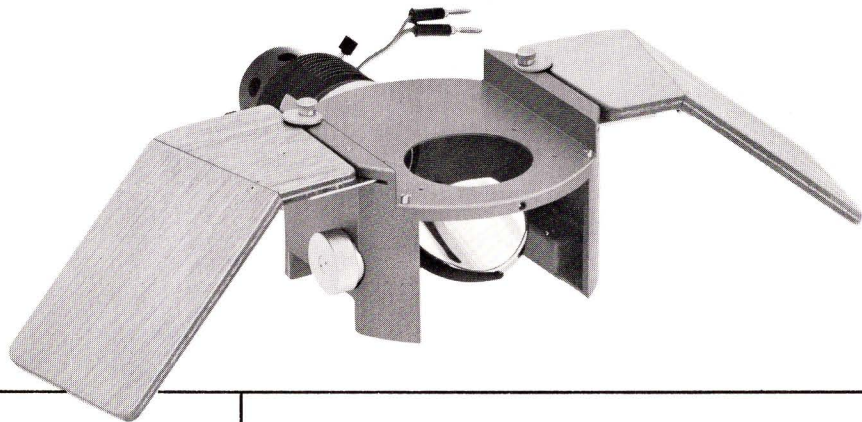

## CENTERING MIRROR PM-ELCS

For use with these PM-EL units for accurate centration or for use with the Trans-Illuminator Base X-DE.

### ORDERING INFORMATION

**Centering Mirror PM-ELCS**  
Stock No. 104-213

## BLUE FILTERS

Square, designed for use with Trans-Illuminator LSD.

### ORDERING INFORMATION

**Blue Clear Filter for LSD (45mm x 60mm)**  
Stock No. 104-143

**Blue Frosted Filter for LSD (45mm x 60mm)**  
Stock No. 104-144

**STAGE PLATES FOR  
PHOTOMACROGRAPHIC STAND VST-1**

**STAGE GLASS (clear)**

Clear stage plate for use with both incident and transmitted light. Color backgrounds can be placed underneath to add contrasts, etc.

**ORDERING INFORMATION**

**Stage Glass (clear)**  
Stock No. 104-130

**STAGE GLASS (opaque white)**

Opaque white stage glass for use with Photomacrographic Stand VST-1. Provides white backgrounds to contrast with dark subjects.

**ORDERING INFORMATION**

**Stage Glass (opaque white)**  
Stock No. 104-131

**STAGE PLATE 45**

Similar to stage plate 28 except with a 45mm center hole. Black finish. Compatible with trans-illuminators or epi-illuminators.



**ORDERING INFORMATION**

**Stage Plate 45**  
Stock No. 104-133

**STAGE PLATE 28**

Can be used with both incident and transmitted light. 28mm center hole. Black finish. Can be used with mechanical stage FM.



**ORDERING INFORMATION**

**Stage Plate 28**  
Stock No. 104-132

**MECHANICAL STAGE FM**

Provides for fine positioning adjustments with pinpoint accuracy. Travels in 52mm x 26mm range. Auxiliary scale indexed in .1mm. For use with stage plate 28.

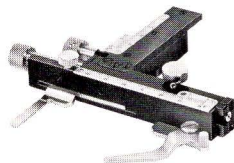

**ORDERING INFORMATION**

**Mechanical Stage FM**  
Stock No. 104-135

**SHADE STAGE PLATE WITH INTERRUPTERS**

Transparent stage glass with 22.9mm hole in center to accept either black or white insert on which subject is placed. Provides compatible light transmission for Lieberkühn reflectors. Inserts included.



**ORDERING INFORMATION**

**Glass Shade Stage Plate**  
Stock No. 104-134

**TRANS-ILLUMINATOR LSD**

A universal type Trans-Illuminator for use with Photomacrographic Stand VST-1 (with or without X-DE Base). When the Lieberkühn Reflector is added, vertical light is also available. Uses a 6-volt, 30-watt bulb. The condenser travels 18mm by rack and pinion for converging, diverging and parallel adjustments of light. Variable aperture for controlling beam width and filter holder for 45mm color correcting, polarizing and neutral density filters.

**ORDERING INFORMATION**

**Trans-Illuminator LSD**

Stock No. 104-142

**Bulb for LSD Illuminator (30 watt)**

Stock No. 104-146



**TRANSFORMER—MODEL TF**

Variable 0 to 8 volt transformer (without meter) for use with X-DE Base or the LSD Trans-Illuminator.

**ORDERING INFORMATION**

**Transformer—Model TF**

Stock No. 104-150



**TRANSFORMER—MODEL TE-II**

Variable 0 to 12 volt transformer with meter to assure consistent light intensity and color temperature for use with X-DE Base or the LSD Trans-Illuminator.

**ORDERING INFORMATION**

**Transformer—Model TE-II**

Stock No. 104-151

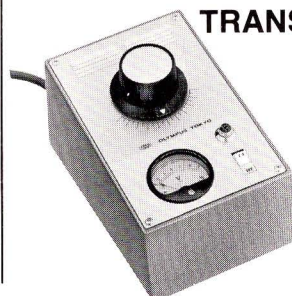

**LIEBERKÜHN REFLECTORS  
PM-LM38 AND PM-LM20**

When used with the LSD trans-illuminator, these reflectors provide for photomicrographs with surprisingly good penetration and lack of shadows. When an insert disc is placed in the center of the stage plate, the light passes around the disc and is reflected onto the subject. Use PM-LM38 with Zuiko 38mm macro lens, PM-LM20 with Zuiko 20mm macro lens.

**ORDERING INFORMATION**

**Lieberkühn Reflector PM-LM20**

Stock No. 104-200

**Lieberkühn Reflector PM-LM38**

Stock No. 104-201



**INCIDENT ILLUMINATOR  
MIRROR HOUSING  
PM-EL20, PM-EL38 and PM-EL80**

A half-mirror built in the housing reflects light into a port in the bottom to evenly illuminate the subject. The PM-EL80 is used with Zuiko 80mm and 50mm macro lenses; the PM-EL38 with the Zuiko 38mm macro lens; the PM-EL20 with the Zuiko 20mm macro lens.

**ORDERING INFORMATION**

**Incident Illuminator Mirror Housing**

**PM-EL20**

Stock No. 104-210

**PM-EL38**

Stock No. 104-211

**PM-EL80**

Stock No. 104-212

**The OM Photomicrography System:  
HOW IT FITS TOGETHER**

Item	Required Accessories	Optional Accessories
Bellows (104-100)	Double Cable Release (104-110)	
VST-1 (104-120)	Bellows (104-100) and Double Cable Release (104-110) VST-E (104-122) B Adapter (104-121) OR Focusing Rail (104-113) and Focusing Stage (104-114) VST-E (104-122) B Adapter (104-121)	X-DE-30 (104-140) X-DE-20 (104-141) LSD (104-142) Stage Glass Trans. (104-130) Stage Glass Opaque (104-131) Mechanical Stage FM (104-135) Shade Stage Plate (104-134) Varimaghi Finder (104-300)
X-DE-30 (104-140)	TF Transformer (104-150) or TE 11 Transformer (104-151) VST-1 (104-120)	
LSD (104-142)	TF Transformer (104-150) or TE 11 Transformer (104-151)	
Mechanical Stage FM (104-135)	Stage Plate 28 (104-132)	
20mm f3.5 Macro Lens (103-700)	PM-MT ob (104-220) Bellows (104-100)	Lieberkühn PM-LM (104-200) Mirror Housing PM-EL 20 (104-210)
38mm f3.5 Macro Lens (103-710)	PM-MT ob (104-220) Bellows (104-100)	Lieberkühn PM-LM 38 (104-201) Mirror Housing PM-EL.38 (104-211)
50mm f3.5 Macro Lens (103-720)		Mirror Housing PM-EL-80 (104-212)
80mm f4.0 Macro Lens (103-730)	Bellows (104-100)	Mirror Housing PM-EL-80 (104-212)