

Macro Mechanism Widens the Possible Applications in 16mm Movie Making

Canon SCOOPIC 16M

16mm Camera with Six-Time Zoom Lens

English Edition



Fast, Versatile Canon Scoopic 16M, Recorder of Facts

6-Time Zoom Lens 12.5–75mm (1/2"–3"), T2.5 (F1.8)

Scoopic 16M has a 6-time zoom lens, consisting of 12 components, 16 elements and affords a fast lens speed of T2.5. Focal length range from 12.5 to 75mm. The object is kept in focus throughout the entire zooming. You can get sharp pictures and true color reproduction. The finder is a parallax-free single-lens reflex type. All matted focus glass assures easy focusing. An aperture opening button is provided to introduce light on the finder before shooting, thus facilitating focusing. Further, you can obtain such useful reference as T/stops and under-exposure and over-exposure warning marks. The finder shutter prevents incidence of light through the finder when you take pictures with your eye off the eyecup.

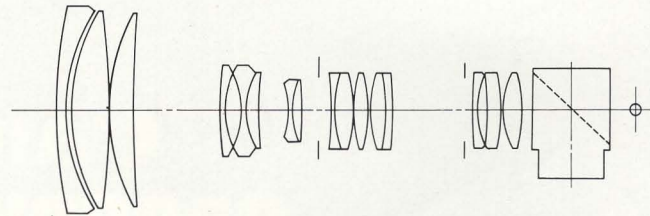

Close-up to As Close As 80mm (3 1/8")

Scoopic 16M is the world's first 16mm camera to have incorporated a macro shooting mechanism. By turning the MACRO ring, you can take a close-up shot of an object, a mere 80mm away from the lens front. You can photograph titles or copy literature without any additional close-up lens.

Multi-Focus Shooting

As you turn the zoom ring from wide-angle to telephoto or vice versa on MACRO, the position in focus changes in one take. This characteristic affords you a special effect where object distance can continuously change from MACRO to infinity or vice versa.

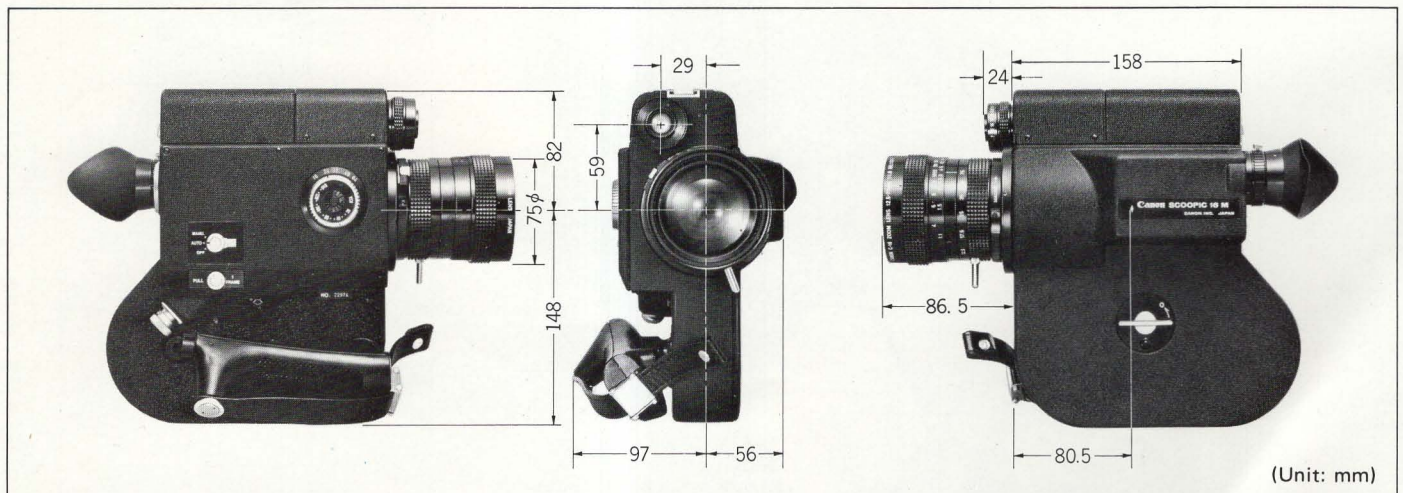
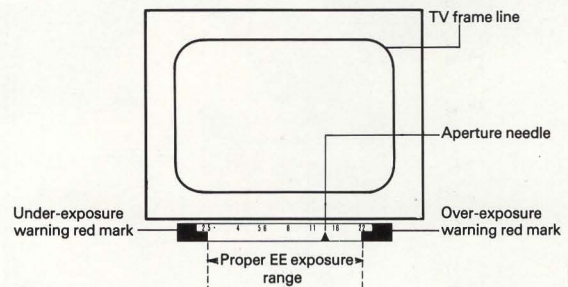

Canon SCOOPIC 16M

Optimum Exposure under Any Weather Condition

Exposure is determined by a responsive and shock-proof servo circuit EE mechanism. The electronic circuit (bridge circuit) immediately analyzes the amount of light reaching a CdS photocell of high sensitivity and automatically controls exposure. Of course, you need not correct exposure even if you change film speed or filming speed (except for single-frame shot). A servomotor promptly adjusts two iris diaphragms installed on the CdS cell side and on the lens side. The Electric Eye operates over a wide film range of ASA 20–640.

Six Filming Speeds of 1 to 64fps

You can select any filming speed among 1, 16, 24, 32, 48 and 64 fps. The shutter opens to 170 degrees. These filming speeds and shutter opening give the following exposure time:

Filming speed, fps	16	24	32	48	64
Exposure time, sec.	1/34	1/51	1/68	1/102	1/136

The Electric Eye does not work for single-frame picture shot. But you can get optimum exposure if you let the Electric Eye operate at 16 fps and set the obtained aperture value. The electronic governor eliminates half opening of the shutter blades and assures perfect single frame shot free from jumping. The frame counter shows the number of frames exposed.

Semiautomatic Film Loading System

Film loading is semiautomatic. Insert the film leader in the guide and the film will automatically thread its way into the takeup spool. The film loop is C-shaped to ensure the fitting of film on the aperture plate, a rational design to make use of film elasticity, resulting in shock-proof and noiseless operation. The film-cutter is built-in to cut off the end of the film leader at a right angle for smooth loading. Power comes from a nickel-cadmium battery. You can charge the battery in 5 hours. On one full charging, you can shoot sixteen rolls of 100 ft (30.5m) film at 24 fps.

- | | |
|---------------------------|-------------------------|
| 1. Pressure plate | 8. Sprocket |
| 2. Film holder | 9. Sprocket |
| 3. Film guide | 10. Film guide |
| 4. Takeup spool shaft | 11. Guide roller |
| 5. Film guide | 12. Takeoff spool shaft |
| 6. Film cutter | |
| 7. Film guide release pin | |

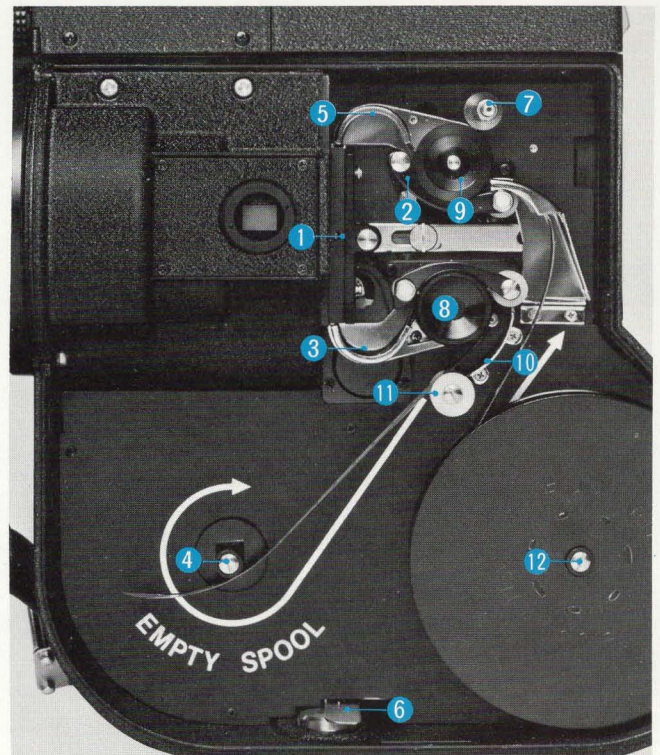

Canon's Scoopic 16M is a refined version of the Scoopic 16 which has enjoyed worldwide popularity as the finest Japanese-made 16mm camera. We achieved the longer durability, greater mobility and wider applicability and have come up with a new camera which requires no complicated operations.

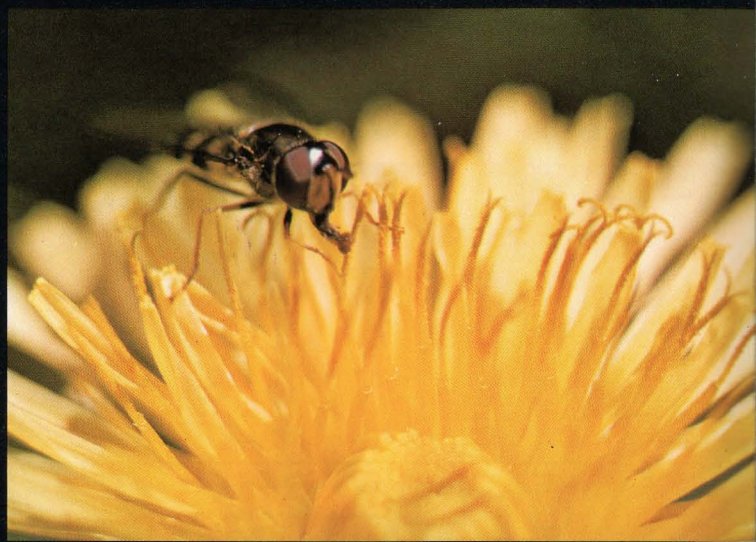

- High-performance lens with 6 : 1 zoom ratio and a fast T2.5 (F1.8).
- The first 16mm camera to incorporate macro shooting mechanism
- Shock-proof servo EE mechanism of quick response
- Wider filming speeds of 16, 24, 32, 48, 64 fps and single frame shot
- Fast, accurate semiautomatic film loading
- Easy-to-hold grip
- Accessory shoe convenient for mounting movie light
- Numerous accessories to provide versatility

Canon Scoopic 16M will meet your requirements for moviemaking in news, medical, industrial or any other field.

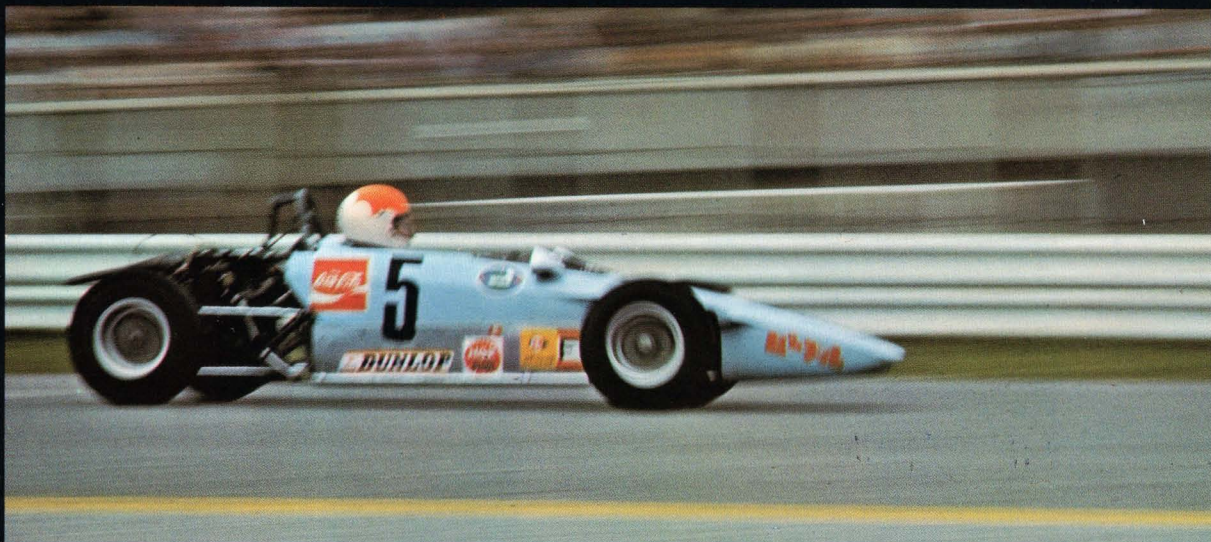
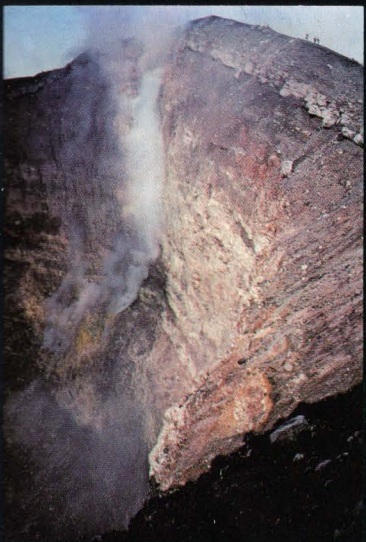

1. CdS window
2. Accessory shoe
3. Zoom lens

5. Focus ring
6. Manual aperture setting scale
7. Manual aperture control ring
8. Macro ring

9. Eyepiece adjusting ring setscrew
10. Eyepiece adjusting ring

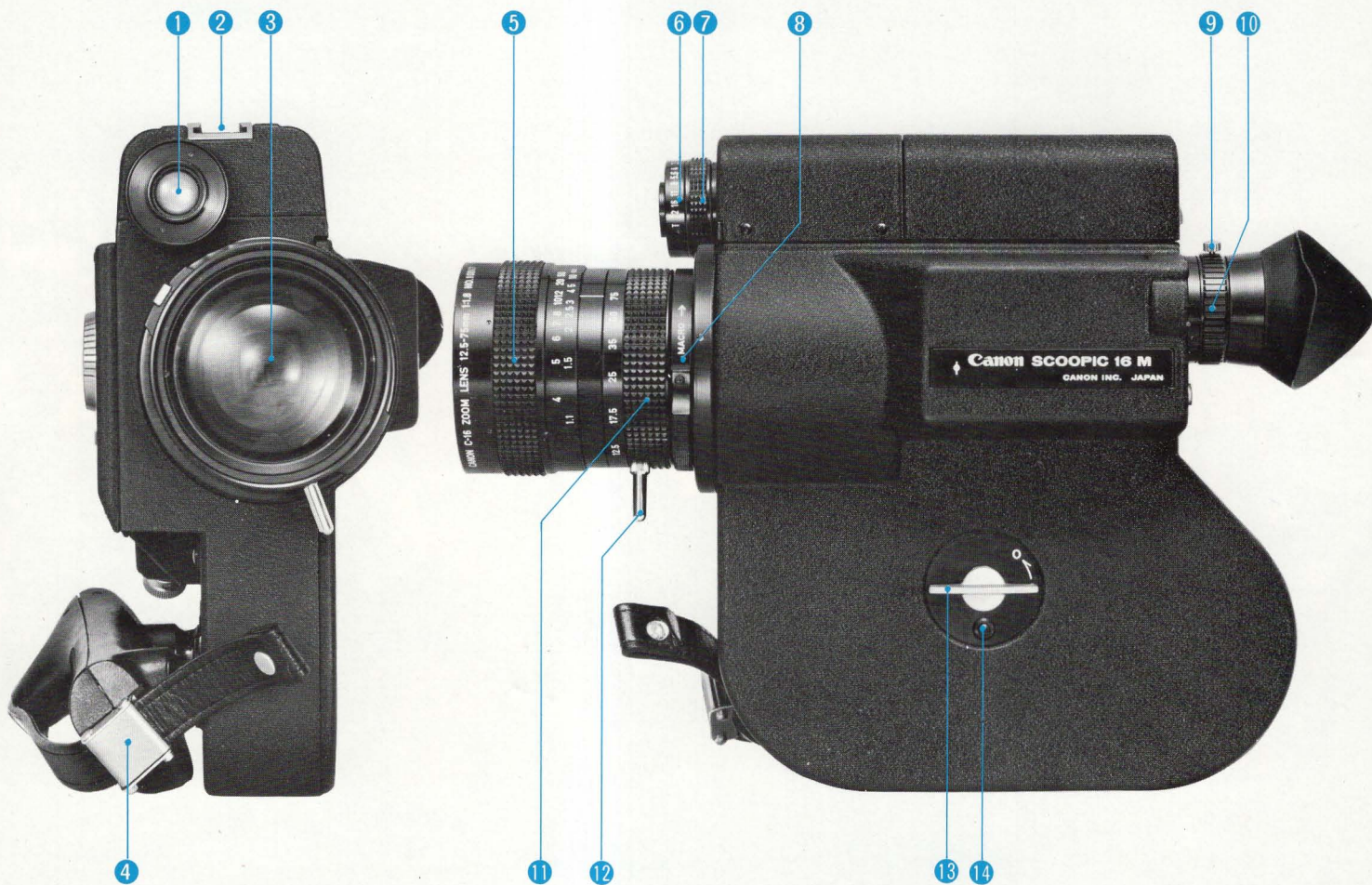

4. Handstrap fastener

11. Zoom ring
12. Zoom lever

13. Side cover knob
14. Side cover lock button

Accessories

● Battery Charger S-12

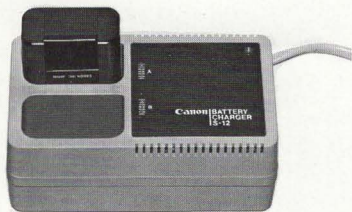

Recharge the battery when the needle of the battery checker stays within the red region. You can recharge it in 5 hours at 20–25°C (68–77°F). The battery can be recharged in time proportional to the number

of rolls of film shot on it; e.g., about two hours is required to recharge a battery from which eight rolls of film are taken.

● Carrying Case



Options

● External Battery Box

For filming in a cold area, put the battery in the external battery box and keep it warm with your body temperature. Thus, battery performance is kept unchanged. The external battery box proves most effective at 0°C or lower.

● Close-up Lenses

Two kinds of close-up lenses are available for enlarging and copying.

- 15. Eyecup
- 16. Finder eyepiece
- 17. Battery chamber
- 18. Battery chamber lock button
- 19. Frame counter
- 20. Footage counter

- 28. Power supply switch
- 29. Single frame shot knob
- 30. Filming speed selector
- 31. Film speed dial
- 32. Macro ring lock release knob

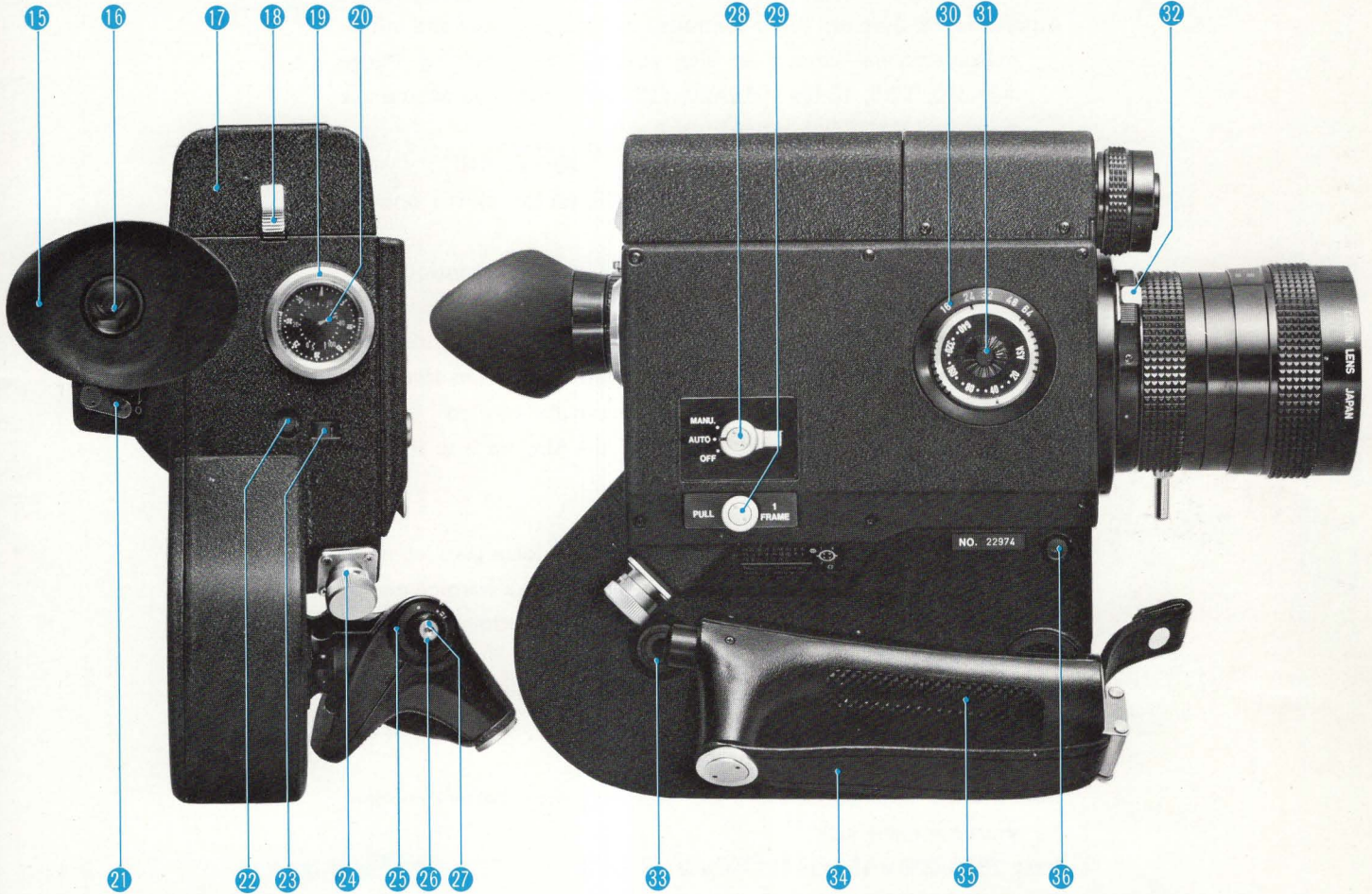

- 21. Finder shutter lever
- 22. Battery checker button
- 23. Battery checker
- 24. External power supply connector

- 25. Running lock scale
- 26. Shutter button
- 27. Release socket

- 33. Film feed indicator
- 34. Handstrap
- 35. Handgrip
- 36. Aperture opening button

• Filters

Filters for black and white film which give varieties of expression and clear pictures. ND filters which reduce intensity of light. Color conversion filters which correct color temperature.

UV, Y1*, Y3, R1, SKY, CCA, CCB, NDB ND4

* screw-in type only

* Use this 4-time ND EE-correction filter on the CdS window for compensation in EE shooting.

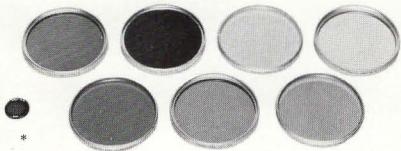

Composition

Scopic 16M camera body	1
Nickel-cadmium battery S-12	1
75mm lens cap	1
72mm lens hood	1
Battery charger S-12	1
Carrying case	1

Specifications

- Type:** 16mm EE mechanism movie camera with macro zoom lens
- Film:** 16mm single or double perforated film of 100 ft. (30.5m)
- Lens:** Focal length 12.5–75mm ($\frac{1}{2}$ "–3"), zoom ratio 6:1, lens speed T2.5 (F1.8), 16 elements in 12 components, front thread 72mm ($2\frac{3}{16}$ ") P 0.75, outer diameter 75mm (3"), minimum object distance 1.1m ($3'7\frac{5}{16}$ ") from film plane, range of macro-operation 80–750mm ($3\frac{1}{8}$ "– $2'5\frac{1}{2}$ ") from front vertex, multipoint focus is possible
- Automatic EE System:** Servo-controlled by CdS photocell and micro-motor, manual control is also possible, EE Coupling Range ASA640, T2.5, 16 fps – ASA20, T22, 64 fps not coupled to single frame and MACRO shooting
- Film Speed:** ASA 20 .. 40 .. 80 .. 160 .. 320 .. 640
(25 32) (50 64) (100 125) (200 250) (400 500)
- Filming Speed:** Single frame, 16, 24, 32, 48, 64 fps, shutter opening angle 170°
- Film Drive:** By a built-in DC micromotor, speed is controlled by electronic governor
- Power Source:** An exclusive 12 V NiCd battery for film drive and automatic aperture control, a fully charged battery runs 16 rolls of 100 ft. film at 24 fps., external batteries can also be used
- Film Loading:** Semi-automatic, just insert the film tip into the film guide, with film cutter
- Zoom & Focus:** Manual
- Viewfinder:** Single-lens reflex type with all-matted focus glass, contains TV frame line, T/stop scales, over/under exposure warning marks, aperture needle, eyepiece is adjustable (–4 to +2diopter), with eyepiece shutter to prevent the backflow of light
- Footage Counter:** Counts exposed footage, automatically returns to "S" when side cover is opened, frame counter, 40 frames in one rotation (1 ft.)
- Others:** Film slack correction knob, accessory shoe, battery checker, shutter running lock
- Size:** 287 x 230 x 153mm ($11\frac{5}{16}$ " x $9\frac{1}{16}$ " x 6")
- Weight:** 3.3 kg (7.3 lbs.)
Set 8.5 kg (18.7 lbs.)
- Battery Charger:** Input voltage selector 100, 110, 120, 200, 220 and 240 V, charging time 5 hours at normal temperature

Canon

CANON INC. 9-9, Ginza 5-chome, Chuo-ku, Tokyo 104, Japan

U.S.A.

NEW YORK — CANON U.S.A., INC.
10 Nevada Drive, Lake Success, Long Island, N.Y. 11040, U.S.A.

MANHATTAN — CANON U.S.A., INC.
600 Third Avenue, New York, N.Y. 10016, U.S.A.

CHICAGO — CANON U.S.A., INC.
457 Fullerton Avenue, Elmhurst, Illinois 60126, U.S.A.

LOS ANGELES — CANON OPTICS & BUSINESS MACHINES CO., INC.
123 East Paularino Avenue, Costa Mesa, California 92626, U.S.A.
CANON OPTICS & BUSINESS MACHINES CO., INC.
3113 Wilshire Blvd., Los Angeles, California 90010, U.S.A.

CANADA
TORONTO — CANON OPTICS & BUSINESS MACHINES CANADA LTD.
3245 American Drive, Mississauga, Ontario, L4V 1B8, Canada

EUROPE, AFRICA
& MIDDLE EAST
AMSTERDAM — CANON AMSTERDAM N.V.
Gebouw 70, Schiphol Oost, Holland

CENTRAL &
SOUTH AMERICA
PANAMA — CANON LATIN AMERICA, INC.
Apartado 7022, Panamá 5, República de Panamá