



BROOKS[®]

BURLEIGH BROOKS INC.



44 BURLEWS COURT
HACKENSACK, NEW JERSEY 07601

Telephone: (201) 489-1300

NEW YORK CITY DEALERS CAN DIAL DIRECT ON BRYANT 9-9085



WEST COAST

219 S. SAN PEDRO STREET
LOS ANGELES, CALIFORNIA 90012

Telephone: (213) 624-5128

SUPER CAMBO VIEW CAMERAS

The Ultra-advanced Large-Format System
for Professionals and Serious Amateurs

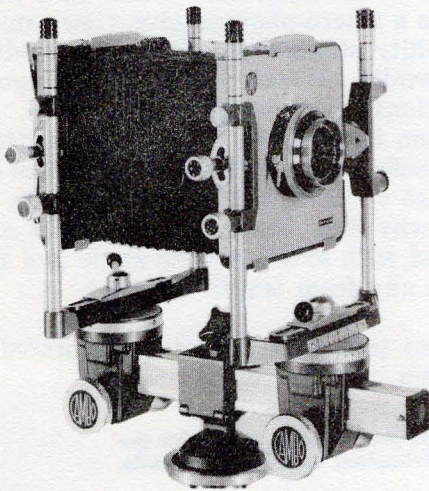

Model I (2¼ x 3¼")

- ★ Full corrective capability
- ★ 4 x 5, 5 x 7, 8 x 10" all use the same lensboard and front standard accessories
- ★ Tilt and swing adjustments on *optical axis*
- ★ Rugged, yet lightweight
- ★ Unique modular construction
- ★ Folds flat for easy storage and portability
- ★ Five models: 2¼ x 3¼", 4 x 5", 5 x 7" and two 8 x 10" models

Name a problem in large-format studio photography and the remarkable Super Cambo system masters it. Offering unmatched flexibility with rugged construction to exacting precision standards, this versatile system provides the widest range of set-up possibilities.

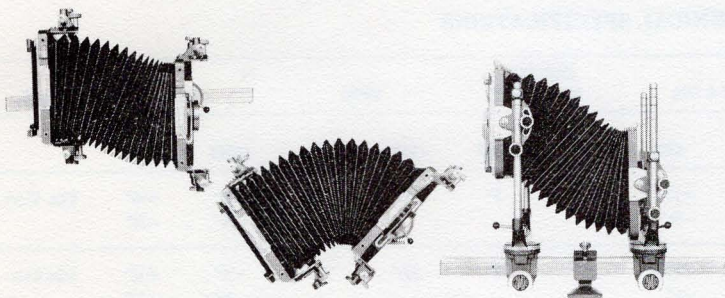

Complete Corrective Capability — Front and rear standards have right-hand focusing knobs with locking knobs on the left, and each has its own spirit level for accuracy. All movements on the camera are equipped with click-stop centering marks to assure precise alignment. Focusing can be done at either standard. Three means of perspective correction are supplied (1) widest range of possible tilts and swings at both lens stage and camera back, (2) flexible lateral movements, and (3) wide-range camera tilt at the mounting head. Rugged, polished monorails available in lengths from 8" to 40"

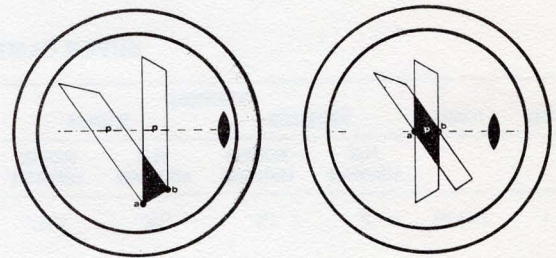

All swings and tilts around optical axis — With many cameras, tilts and swings affect the image in the ground glass; moving it about or losing it completely. This necessitates relocating and refocusing the image. In the Super Cambo, the image remains centered and the focus remains sharp and precise, regardless of the degree of tilt and swing. Reason is the advanced design in which both tilts and swings are pivoted around a central point — the optical axis. (Some cameras rely on a pivoting point at the base of their standards which only provide off axis adjustments.)

BURLEIGH BROOKS INC.

SUPER CAMBO VIEW CAMERAS

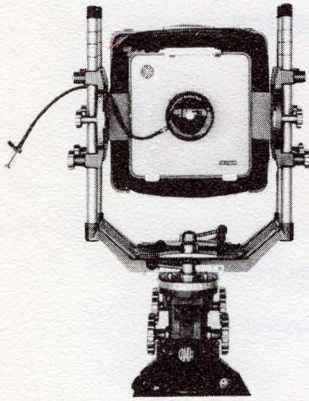

Super Wide Angle Camera

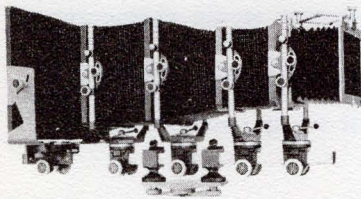

As Macro Camera

Versatile modular design — In addition to functioning as a view camera, the Super Cambo may also be used as a super wide-angle camera or as a macro-photographic view camera. This remarkable flexibility stems from its unique modular construction which permits an extremely wide range of interchangeable operations and special combinations. Unlimited bellows extension is achieved by adding additional camera standards and bellows. Interchangeable bellows and standards enable the use of various film formats with one basic camera. That's why the Super Cambo ranks as a *system* — it can be used with extreme wide angle and tele-photo lenses, as well as any focal length between.

There is no view camera task that cannot be mastered by the Super Cambo System.

Note: Schneider lenses are the perfect team-mates for the Super Cambo camera. See Schneider catalog for details.

SUPER CAMBO TECHNICAL SPECIFICATIONS

MODEL	FORMAT	DIMENSIONS*				RISE & FALL		HORIZONTAL DISPLACEMENT		SWING		TILT		WEIGHT
		COMPRESSED FLAT LENSBOARD	COMPRESSED RECESSED LENSBOARD	EXTENDED FLAT LENSBOARD	EXTENDED RECESSED LENSBOARD	FRONT	BACK	FRONT	BACK	FRONT	BACK	FRONT	BACK	
I	2¼ x 3¼	2"	1¾"	11¾"	11¾"	+1⅞" -¾"	+1⅞" -¾"	2"	2"	360°	360°	+30° -30°	+30° -30°	6 lbs. 10 ozs.
II	4 x 5	3"	2"	17⅞"	16⅞"	+2⅞" -1"	+2⅞" -1"	2"	2"	360°	360°	+30° -30°	+30° -30°	9 lbs. 6 ozs.
III	5 x 7	3"	2"	21¼"	20¼"	+2⅞" -1"	+2¾"	2"	2"	360°	360°	+30° -30°	+30° -30°	11 lbs.
IV	8 x 10	4⅞"	3⅞"	29½"	28½"	+2⅞" -1"	+4¾"	2"	2"	360°	-45° +45°	+30° -30°	+30° -30°	15 lbs. 7 ozs.
IVB	8 x 10	4⅞"	3⅞"	29½"	28½"	+2⅞" -1"	0"	2"	0"	360°	-45° +45°	+30° -30°	+30° -30°	15 lbs. 7 ozs.

*Measured from Lensboard to Film Plane

BURLEIGH BROOKS INC.

NEW FROM SUPER CAMBO

Your choice of either a single or double base control lock on each of your Cambo Camera Standards.

Single Lock (Std.)

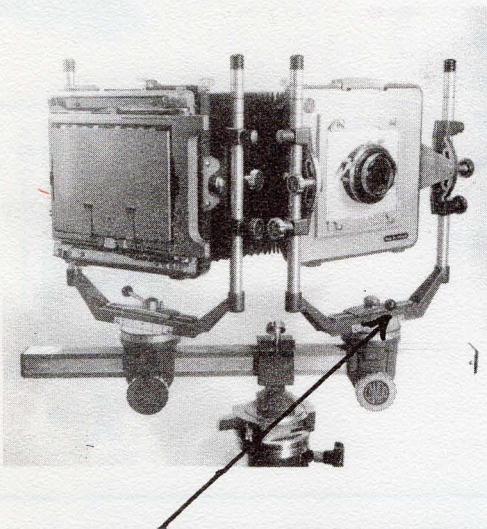

A single locking lever controls both the lateral and swing movements of the Camera Standard.

Double Lock (New)

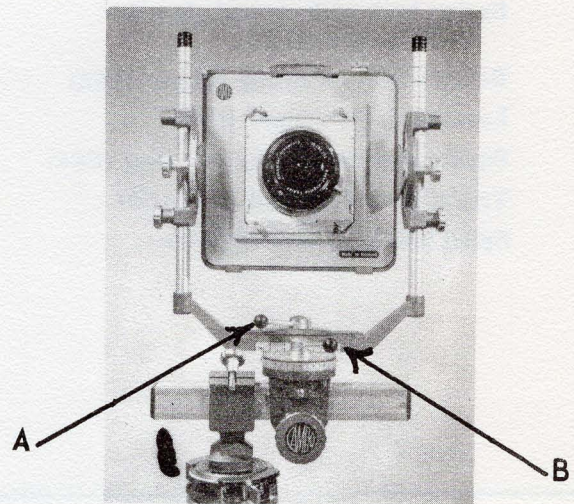

Locking lever A controls lateral movement.
Lever B controls swing movement.

The single lock system of the Super Cambo Camera has proven itself to be a most effective control for the camera standards. It offers quick locking control of both the lateral and swing movements of the standards. However, there are photographers who prefer separate locks for each of these movements. The new double locking system of the Super Cambo Camera provides this feature. When ordering your Cambo Camera please specify "with single lock" or "with double lock" on the order. See price list for price information on Cambo Cameras with the new double lock system.

2 1/4 x 3 1/4 SUPER CAMBO VIEW CAMERA

**2 1/4 x 3 1/4" Super Cambo View Camera
Model I Complete** *(Specify Single or Double Lock.)*

Catalog No.
14/2x3C1

Consists of:

Front standard (holds lensboard) (C61)	14/C61
Rear standard (holds spring back) (C61)	14/C61
Spring back with ground glass for double holders (C60)	14/C60
Bellows with mounting flanges (C62)	14/C62
Lensboard, 4 7/8" square (C63)	14/C63
Square monorail track, 11 1/2" long (C64)	14/C64
Tripod mounting head, fixed (C9)	14/C9
Spirit levels, set of 3 (C56/3)	14/C56/3

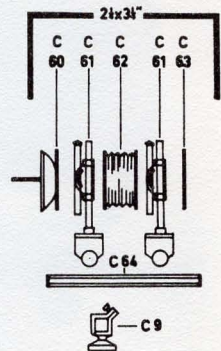
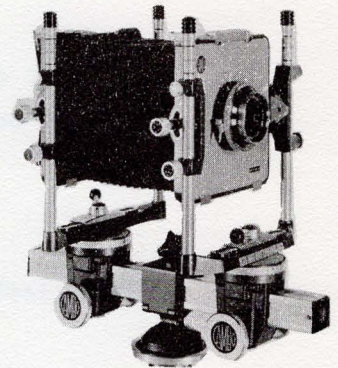

4 x 5 SUPER CAMBO VIEW CAMERA

**4 x 5 Super Cambo View Camera
Model II Complete** *(Specify Single or Double Lock.)*

Catalog No.
14/4x5C2

Consists of:

Front standard (holds lensboard) (C5)	14/C5
Rear standard (holds spring back) (C5)	14/C5
Spring back with ground glass for double holders (C1)	14/C1
Bellows with mounting flanges (C6)	14/C6
Lensboard, 6 1/16" square (C7)	14/C7
Square monorail track, 17 1/2" long (C10)	14/C10
Tripod mounting head, fixed (C9)	14/C9
Spirit levels, set of 3 (C56/3)	14/C56/3

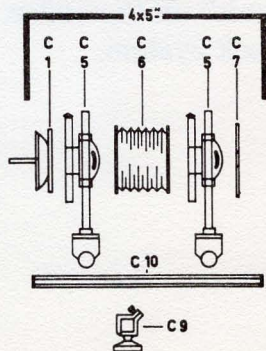

5 x 7 SUPER CAMBO VIEW CAMERA

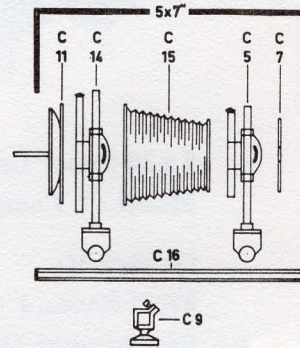
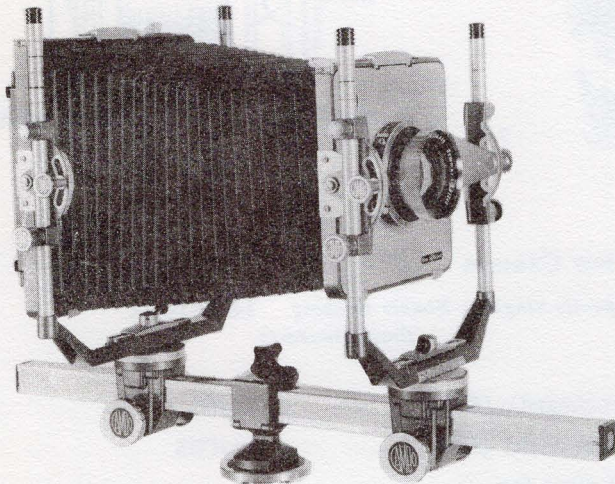

5 x 7 Super Cambo View Camera

Model III Complete (*Specify Single or Double Lock.*)

Catalog No.

14/5x7C3

Consists of:

Front standard (holds lensboard) (C5)	14/C5
Rear standard (holds spring back) (C14)	14/C14
Spring back with ground glass for double holders (C11)	14/C11
Bellows with mounting flanges (C15)	14/C15
Lensboard, 6 $\frac{7}{16}$ " square (C7)	14/C7
Square monorail track, 21 $\frac{1}{4}$ " long (C16)	14/C16
Tripod mounting head, fixed (C9)	14/C9
Spirit levels, set of 3 (C56/3)	14/C56/3

BURLEIGH BROOKS INC.

8 x 10 SUPER CAMBO VIEW CAMERAS 2 MODELS

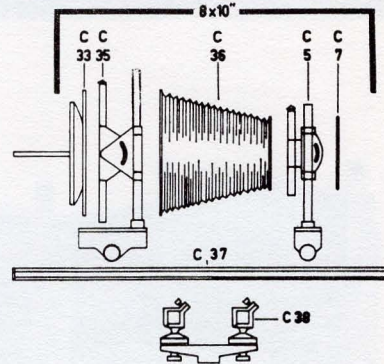
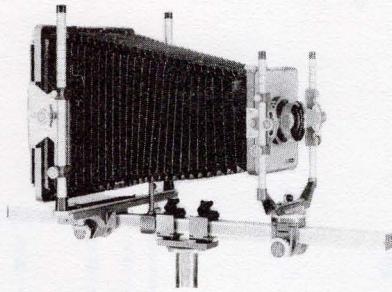

8 x 10 Super Cambo View Camera **Catalog No.**
Model IV Complete (*Specify Single or Double Locking* **14/8x10C4**
Front Standard)

Consists of:

Front standard (holds lensboard) (C5)	14/C5
Rear standard (holds spring back) (C35)	14/C35
Spring back with ground glass for double holders (C33)	14/C33
Bellows with mounting flanges (C36)	14/C36
Lensboard, 6 $\frac{7}{16}$ " square (C7)	14/C7
Square monorail track, 30" long (C37)	14/C37
Tripod mounting head, (heavy duty) fixed (C38)	14/C38
Metal bellows support (C19)	14/C19
Spirit levels, set of 3 (C56/3)	14/C56/3

8 x 10 Super Cambo View Camera **Catalog No.**
Model IVB Complete (*Specify Single or Double Locking* **14/8x10C4B**
Front Standard)

Same as Model IV, but with rear standard (C35B) which has tilt and swing movements only — no lateral, rise or fall movements.

Consists of

Front standard (holds lensboard) (C5)	14/C5
Rear standard (holds spring back) (C35B)	14/C35B
Spring back with ground glass for double holders (C33)	14/C33
Bellows with mounting flanges (C36)	14/C36
Lensboard, 6 $\frac{7}{16}$ " square (C7)	14/C7
Square monorail track, 30" long (C37)	14/C37
Tripod mounting head, (heavy duty) fixed (C38)	14/C38
Metal bellows support (C19)	14/C19
Spirit levels, set of 3 (C56/3)	14/C56/3

BURLEIGH BROOKS INC.

SUPER CAMBO ACCESSORIES

Front Standard Accessories

Lensboard—Flat

For Camera:
 $2\frac{1}{4} \times 3\frac{1}{4}$ " — $4\frac{7}{8}$ " square 14/C63
 4×5 , 5×7 8×10 " — $6\frac{7}{16}$ " square 14/C7
For use on 5×7 " rear standard— $8\frac{1}{16}$ " square 14/C98



Lensboard—Recessed

For Camera:
 $2\frac{1}{4} \times 3\frac{1}{4}$ " — $4\frac{7}{8}$ " square 14/C72
 4×5 , 5×7 8×10 " 14/C42
Rear standard for 5×7 " 14/C99

Linhof Lensboard Adapter

Accepts lenses on Linhof lensboards for mounting on Super Cambo. No dismantling of mounted lens required.

For Camera:
 4×5 , 5×7 , 8×10 " 14/C93

Graphic Lensboard Adapter

Same as above but for mounted Graphic lenses. 14/C94

Lenshood—Standard

Square bellows type. Can be adjusted and locked in any position. Easily mounted or removed from camera.

For Camera:
 $2\frac{1}{4} \times 3\frac{1}{4}$ " 14/C67
 4×5 , 5×7 8×10 " 14/C8

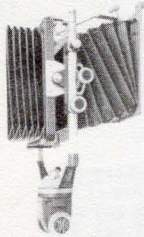

Lenshood—Deluxe with filter holder.

Same as above but with filter holder for 4 " square filters, vignettors, and other front of lens devices.

For Camera:
 $2\frac{1}{4} \times 3\frac{1}{4}$ " 14/C68
 4×5 , 5×7 , 8×10 " (New swing up design) 14/C100

Filter Holders only for filter holder lenshood

For $2\frac{1}{4} \times 3\frac{1}{4}$ " deluxe lenshood 14/C79

For 4×5 , 5×7 8×10 " deluxe lenshood 14/C89

Rear Standard Accessories

Bracket for Viewing Hood

A convenient support for cloth viewing hoods. Easily mounted or removed from camera.

For Camera:
 $2\frac{1}{4} \times 3\frac{1}{4}$ " 14/C73
 4×5 , 5×7 " 14/C4
 8×10 " 14/C34

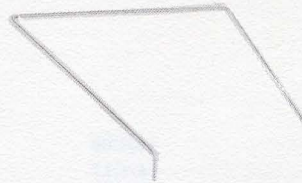

Roll Film Adapter Backs

For use with Graphic type roll film holders
Standard Type—with removable ground glass panel.

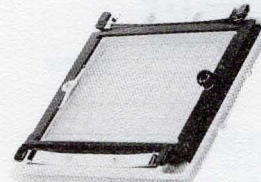

For Camera:
 $2\frac{1}{4} \times 3\frac{1}{4}$ " 14/C65
 4×5 " 14/C59
 4×5 " (For $2\frac{1}{4} \times 3\frac{1}{4}$ " Graflex Roll Film Holder) 14/C91
 5×7 " 14/C49
 8×10 " 14/C53

Deluxe Rack-Over Type with sliding ground glass panel.

For Camera:
 4×5 " 14/C40
 5×7 " 14/C41

Reducing Backs

To Reduce
From —to:
 4×5 " — $2\frac{1}{4} \times 3\frac{1}{4}$ " 14/C3
 5×7 " — 4×5 " 14/C47
 5×7 " — $2\frac{1}{4} \times 3\frac{1}{4}$ " 14/C48
 8×10 " — 5×7 " 14/C51
 8×10 " — 4×5 " 14/C50
 8×10 " — $2\frac{1}{4} \times 3\frac{1}{4}$ " 14/C52

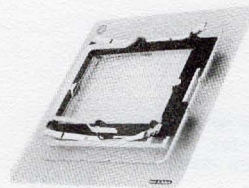

Dividing Backs

For taking three exposures on a single sheet of film. Used for identification purposes.

For Camera:
 $2\frac{1}{4} \times 3\frac{1}{4}$ " — 3 exposures on $2\frac{1}{4} \times 3\frac{1}{4}$ " film 14/C75
 4×5 " — 3 exposures on 4×5 " film 14/C81
 4×5 " — 3 exposures on $2\frac{1}{4} \times 3\frac{1}{4}$ " film 14/C82
 5×7 " — 3 exposures on 4×5 " film 14/C83
 5×7 " — 3 exposures on $2\frac{1}{4} \times 3\frac{1}{4}$ " film 14/C84

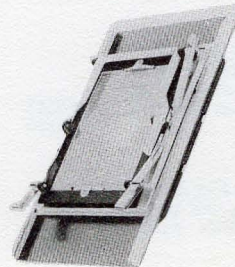

SUPER CAMBO ACCESSORIES

Special Bellows and Bellows Accessories

Wide Angle Bellows

Finest soft and supple leather accordion construction. Provides for full utilization of the cameras movements with extreme wide angle lenses. Will not sag into lens axis.

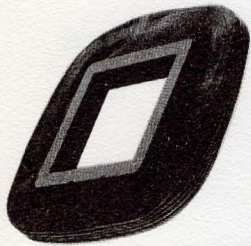

For Camera:

2 1/4 x 3 1/4"	14/C69
4 x 5"	14/C17
5 x 7"	14/C18
8 x 10"	14/C80

Bellows—Tapered from 4 x 5" to 2 1/4 x 3 1/4" connects 4 x 5" standards to 2 1/4 x 3 1/4" standards 14/C76

Bellows—Tapered from 8 x 10" to 5 x 7" connects 8 x 10" (C35) standards to 5 x 7" (C14) standards 14/C97

Bellows—Parallel from 5 x 7" to 5 x 7" connects two 5 x 7" (C14) standards 14/C96

Bellows Support

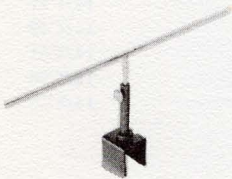

Supplied with 8 x 10" models. Provides support for sagging bellows. Mounts on monorail. For all cameras 14/C19

Special Monorails and Monorail Accessories

Monorails—Special Lengths
Available in lengths from 4" to 40" in multiples of 4 inches. Specify length when ordering 14/C45
Length



Connection Clamp For Monorails
Connects two rails end to end for extreme bellows extension. 14/C101

Tripod Mounting Heads

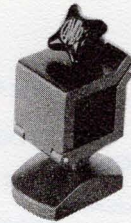

Standard Type—Fixed
Supplied with all models except 8 x 10" 14/C9

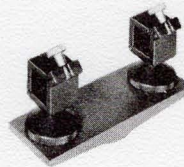

Heavy Duty Type—Fixed
Supplied with 8 x 10" models. Double mounting heads provide rigid support. 14/C38



Revolving Type—Universal Joint Design. Provides full tilting movements for camera on tripod. For all cameras. 14/C55

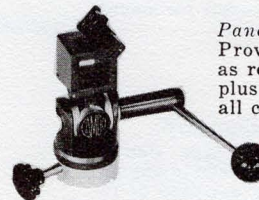

Panorama and Tilting Head
Provides full tilt movements as revolving type head above, plus full pan movements. For all cameras. 14/C95

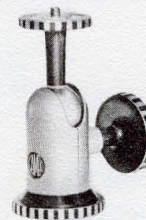

Universal Ball-Joint Tripod Head
Provides full movement of a camera through an arc of 180° with absolute lock in any position. Weighs only 7 ozs. Single locking knob locks both swivel head and panning base. For cameras up to 4 x 5" size. 14/CB11

Miscellaneous

Spirit Level 14/C56

Blank Adapter Plate For 8 x 10"
For special applications. Can be machined to accept a wide variety of instruments or accessories. Lensboards are used for this purpose with camera models 2 1/4 x 3 1/4" to 5 x 7" 14/C87

Extenders
Upright for 4 x 5 camera 14/C85

Replacement Ground Glasses—Ruled

<i>For camera:</i>	
2 1/4 x 3 1/4"	14/C74
4 x 5"	14/C43
5 x 7"	14/C44
8 x 10"	14/C54

SUPER CAMBO CARRYING CASES

Fibre Cases

These attractive cases of grey aero fibre construction are extremely light weight and rugged. Foam lined where needed, the cases are compartmentized to best utilize all available space.

Compact Model

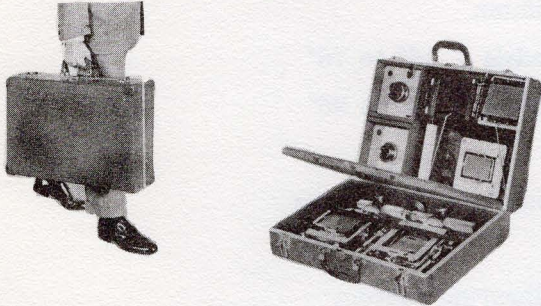

The ideal case for the traveling Cambo photographer. Divided in half with a foam padded separator, one side of case holds flat lying camera, other side holds a generous assortment of lenses and/or accessories.

L W H

Size 23" x 7 $\frac{1}{4}$ " x 15 $\frac{1}{2}$ "

Weight: 9 $\frac{1}{2}$ lbs.

For 2 $\frac{1}{4}$ x 3 $\frac{1}{4}$, 4 x 5 or 5 x 7

14/C20A

Conventional Model

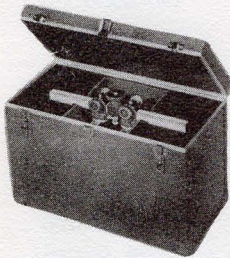

This case holds camera in inverted position completely assembled for immediate use. The two end compartments provide ample storage space for lenses and/or accessories.

L W H

Size 22 $\frac{1}{4}$ " x 10 $\frac{3}{4}$ " x 12 $\frac{3}{4}$ "

Weight: 8 lbs.

For 2 $\frac{1}{4}$ x 3 $\frac{1}{4}$ or 4 x 5

14/C20B

Deluxe Metal Cases

These cases are offered to those photographers who require the extra protection afforded by the metal construction.



Conventional view camera case design similar to 14/C20B case described above. Camera is carried in inverted position completely assembled for immediate use. DeLuxe compartmentized interior plus heavy duty reinforced metal construction insures full protection for camera, lenses and accessories.

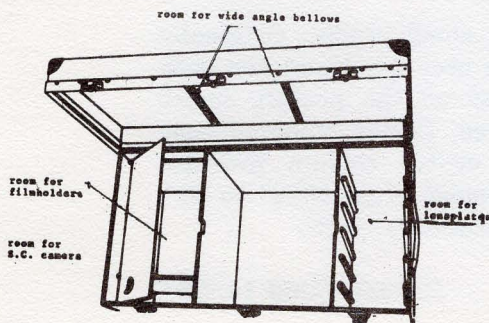

L W H Weight

For 2 $\frac{1}{4}$ x 3 $\frac{1}{4}$ 16 $\frac{1}{2}$ " x 9 $\frac{1}{2}$ " x 13 $\frac{1}{2}$ " 11 lbs. 14/670

4 x 5 22 $\frac{1}{2}$ " x 11" x 15 $\frac{1}{2}$ " 16 lbs. 14/C20

5 x 7 24" x 12 $\frac{3}{4}$ " x 16" 18 lbs. 14/C21

8 x 10 31" x 16 $\frac{3}{4}$ " x 18 $\frac{1}{2}$ " 35 lbs. 14/C39

BURLEIGH BROOKS INC.

SUPER CAMBO

STUDIO CAMERA STANDS

These high quality precision camera stands bring into the large camera studio a degree of camera mobility that normally would be associated with small format cameras. The ease with which these large stands can be maneuvered about the studio and adjusted for camera position is truly remarkable. Interchangeable counter balances assure proper balancing of camera(s) for smooth, effortless control.

Standard Model

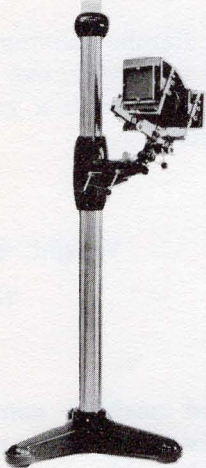

— Specifications —

- Satin chrome finished 5" steel column
- Camera level adjustments — Models I 16" to 76"
Models II 16" to 96"
- Nylon bearings
- Continuous 360° rotation of camera around column
- Fully adjustable stand head
- Bases equipped with locking ballbearing casters

Standard Model	Height	Weight	Catalog Code
(illustrated above)	7 ft.	170 lbs.	14/SSTI
	9 ft.	180 lbs.	14/SSTII

DeLuxe Model

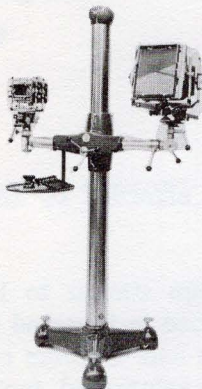

Same features as above Standard Model, but with gear driven laterally adjustable camera mounting arms which permit side-to-side adjustment of camera(s). This feature eliminates the necessity of re-positioning the column stand when an adjustment to either side is needed. Camera can be extended a full 30" from column. Sliding arm equipped with camera mounts at both ends for simultaneous use of two cameras. Conveniently mounted 16" accessory shelf included.

Height	Weight	Catalog Code
7 ft.	200 lbs.	14/AST I
9 ft.	210 lbs.	14/AST II

Compact Model



The ideal camera stand for the small studio. Originally designed for identification camera use, this stand has been acclaimed by many photographers as the perfect choice whenever space must be considered. Caster mounted base provides mobility Gear driven center column provides smooth, fast camera level adjustment from 39½" to 61" Supplied complete with 12" x 12" accessory shelf.

Weight: Approximately 85 lbs.

Catalog Code 14/BST

BURLEIGH BROOKS INC.

SUPER CAMBO

Multishot camera

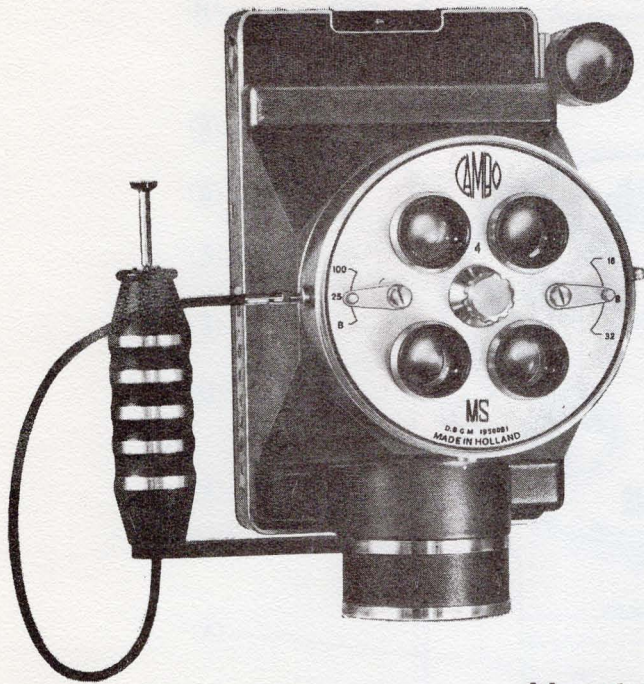

USES:

A Polaroid® filmpack

PROVIDES:

four identical or
different photographs
in 15 seconds

saves you money

saves you time

gives satisfaction to
your clients

Polaroid® is a registered trade mark of the Polaroid Corporation, Cambridge, Mass., U.S.A.

like this or like that

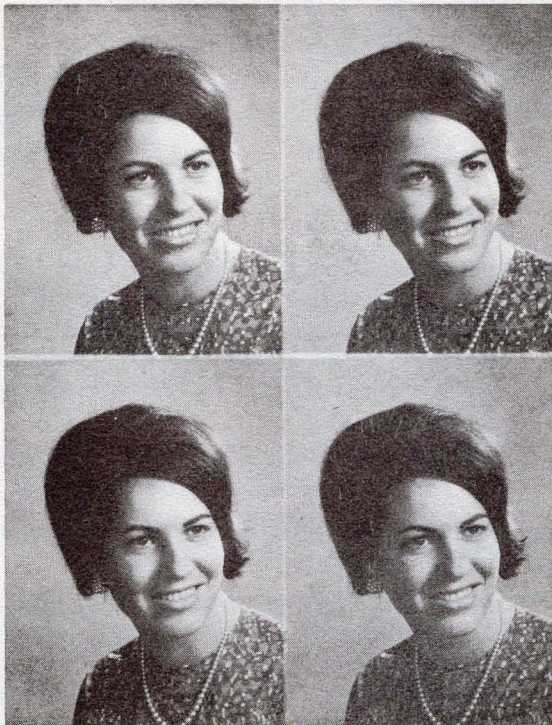

IN 15
SECONDS



actual size

BURLEIGH BROOKS INC.

SUPER CAMBO

Multishot camera

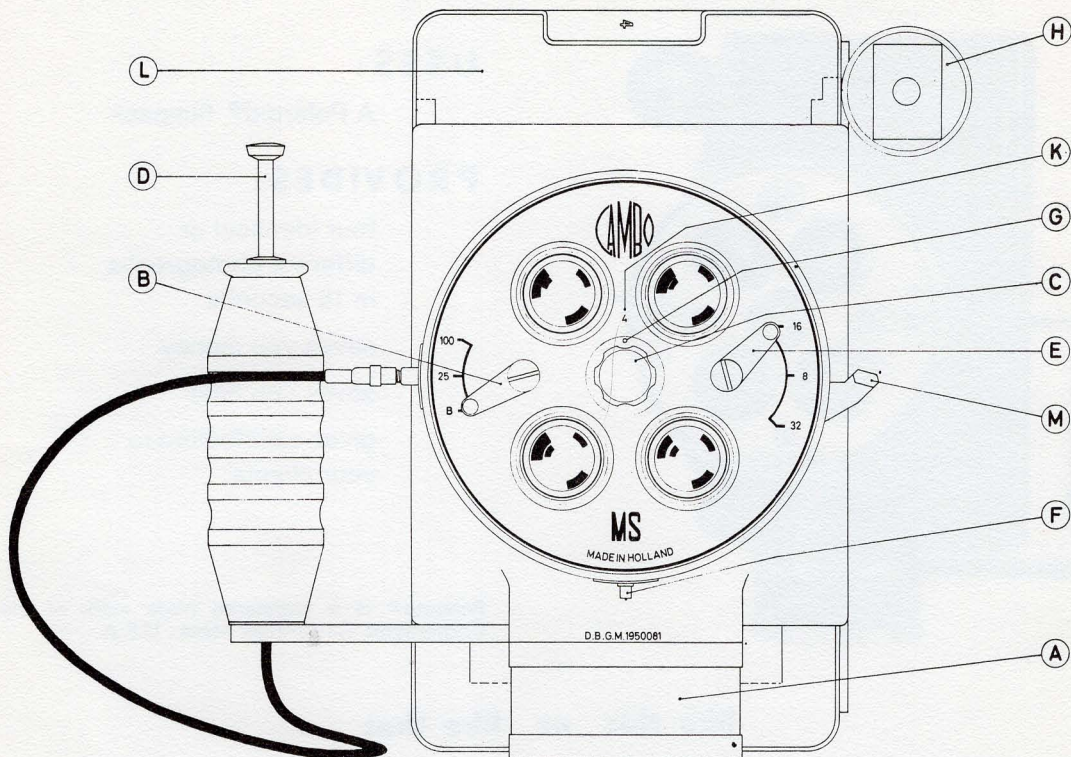

- | | | |
|--|-----------------------------------|------------------------------------|
| A. Base with $\frac{3}{8}$ Whit thread | E. Lever to adjust iris diaphragm | K. Marker for four identical views |
| B. Lever to adjust shutter speed | F. Flash contact | L. Polaroid® magazine |
| C. Selector knob | G. Red spot | M. Shutter cocking lever |
| D. Cable release | H. View-finder | |

The Cambo MS camera is fitted with four Radionar lenses made by Jos. Schneider-Bad Kreuznach. These four identical lenses have an aperture of f:8 and a focal length of 125mm, and are factory matched before mounting.

The camera has a fixed focus distance of 1.25m from the subject to be taken. Thanks to the considerable depth of focus of the lenses, it is possible to take a subject between 1 and 1.5m from the camera and so obtain the correct size photograph.

The camera is provided with a Polaroid® magazine (L) in which Polaroid Land® film packs are used: type 107 for black and white pictures and type 108 for colour pictures, both of these sufficient for taking eight shots.

(The time required for developing black and white photographs is 15 seconds, for colour photographs one minute)

The shutter mounted in the MS camera was developed especially for this camera. There are two shutter speeds: 1/25 sec and 1/100 sec + time exposure, all of them adjusted by lever (B). Con-

sidering the purpose of this camera, this is largely sufficient. The synchronized shutter (F) follows the principle of a roller-blind shutter and is mounted between lenses. The iris diaphragm developed for this special purpose, is adjusted by lever (E) and has three positions, i.e. 8 - 16 - 32, whereas intermediate positions are possible.

The view-finder (H) is adjusted to a fixed distance of 1.25 m. The base of the camera is provided with a $\frac{3}{8}$ Whit thread (A).

The shutter is cocked by lever M, and triggered by the cable release (D) mounted in the handgrip.

When the red spot (G) of button (C) is opposite figure 4 (K) on the cover plate, four identical photographs are taken. In addition to this, the Cambo MS camera offers the possibility of taking four different pictures. This is done by turning button (C) with red spot (G) so that it points to the first lens. In this position the shutter only fires on the lens selected. The next three pictures are taken in the same way.

The weight of the Cambo MS camera is 2.5 kg.

BURLEIGH BROOKS INC.

SUPERCAMBO VIEW CAMERAS - 2¼" X 3¼" STANDARD MODEL



<u>CATALOG NO.</u>	<u>DESCRIPTION</u>	<u>SUGGESTED LIST</u>	<u>NET TO DEALER</u>
CAM/014/2X3C1	2¼" x 3¼" SUPERCAMBO View Camera, Model I, Complete - - - - - Consists of: Front standard (holds lens board) - C61 Rear standard (holds spring back) - C61 Spring back with ground glass for double holders - C60 Bellows with mounting flanges - C62 Lens board, 4-7/8 x 4-7/8 in. - C63 Square monorail track, 11½ in. long - C64 Tripod mounting head, fixed - C9 Spirit levels, set of 3 - C56/3	\$ 270.00	\$ 202.50
<u>INDIVIDUAL PARTS AND ACCESSORIES FOR 2¼" X 3¼" SUPERCAMBO I</u>			
CAM/014/C61J	Standards, two required; one for front (holds lens board) one for rear (holds spring back) - C61 - each - - - - -	\$ 111.00	\$ 83.25
CAM/014/C60J	2¼" x 3¼" Spring back with ground glass - C60 - - - - -	28.00	21.00
CAM/014/C62J	Bellows with mounting flanges - C62 - - - - -	15.00	11.25
CAM/014/C69J	Wide angle bellows - C69 - - - - -	38.00	28.50
CAM/014/C63J	Lens board, 4-7/8 x 4-7/8 in. - C63 - - - - -	3.00	2.25
CAM/014/C72J	Recessed lens board - C72 - - - - -	8.00	6.00
CAM/014/C64J	Square monorail track, 11½ in. long - C64 - - - - -	8.00	6.00
CAM/014/C45J	Additional square monorail - special order - from 4 inches to 40 inches - C45 - per 4 inches - - - - -	4.00	3.00
CAM/014/C09J	Tripod mounting head, fixed - C9 - - - - -	13.00	9.75
CAM/014/C55J	Revolving mounting head, universal joint - C55 - - - - -	35.00	26.25
CAM/014/C95J	Panoram and tilting head - C95 - - - - -	52.00	39.00
CAM/014/C67J	Special lens hood, bellows type - C67 - - - - -	45.00	33.75
CAM/014/C68J	Special lens hood, bellows type with filter holder - C68 - -	87.00	65.25
CAM/014/C79J	Filter frame for special lens hood - C79 - - - - -	14.00	10.50
CAM/014/C75J	Dividing back for 3 exposures on 2¼" x 3¼" - C75 - - - - -	115.00	86.25
CAM/014/C65J	Adapter back with removable ground glass panel, for use with roll film holder - C65 - - - - -	33.00	24.75
CAM/014/C73J	Metal bracket for focusing cloth - C73 - - - - -	3.00	2.25
CAM/014/C74J	Ruled ground glass - 2¼" x 3¼" - C74 - - - - -	4.00	3.00
CAM/014/C56J	Spirit level - C56 - - - - -	2.00	1.50
CAM/014/C70J	*Carrying Case - C70 - - - - -	----	----

*in preparation

Prices Subject To Change Without Notice.

BROOKS • BURLEIGH BROOKS INC.

SUPERCAMBO VIEW CAMERAS 4" X 5" STANDARD MODEL

<u>CATALOG NO.</u>	<u>DESCRIPTION</u>	<u>SUGGESTED LIST</u>	<u>NET TO DEALER</u>
CAM/014/4X5C2	4" x 5" SUPERCAMBO View Camera, Model II, Complete - - - - - Consists of: Front standard (holds lens board) - C5 Rear standard (holds spring back) - C5 Spring back with ground glass for double holders - C1 Bellows with mounting flanges - C6 Lens board, 6-7/16 in. square - C7 Square monorail track, 17½ in. long - C10 Tripod mounting head, fixed - C9 Spirit levels, set of 3 - C56/3	\$ 295.00	\$ 221.25
<u>INDIVIDUAL PARTS AND ACCESSORIES FOR 4" X 5" SUPERCAMBO II</u>			
CAM/014/C05J	Standards, two required; one for front (holds lens board) one for rear (holds spring back) - C5 - each - - - - -	\$ 117.00	\$ 87.75
CAM/014/C01J	4" x 5" Spring back with ground glass - C1 - - - - -	33.00	24.75
CAM/014/C43J	Ruled ground glass, only - 4" x 5" - C43 - - - - -	5.00	3 75
CAM/014/C06J	Bellows with mounting flanges - C6 - - - - -	23.00	17.25
CAM/014/C17J	Wide angle bellows - C17 - - - - -	46.00	34.50
CAM/014/C19J	Metal bellows support - (prevents sagging) - C19 - - - - -	15.00	11.25
CAM/014/C07J	Lens board 6-7/16 in. square - C7 - - - - -	4.00	3.00
CAM/014/C42J	Recessed lens board - C42 - - - - -	8.00	6.00
CAM/014/C10J	Square monorail track, 17½ in. long - C10 - - - - -	11.00	8.25
CAM/014/C45J	Additional square monorail - special order - from 4 inches to 40 inches; per 4 inches - C45 - - - - -	4.00	3 00
CAM/014/C09J	Tripod mounting head, fixed - C9 - - - - -	13.00	9 75
CAM/014/C55J	Revolving mounting head, universal joint - C55 - - - - -	35.00	26 25
CAM/014/C95J	Panoram and tilting head - C95 - - - - -	52.00	39 00
CAM/014/C08J	Special lens hood, bellows type - C8 - - - - -	49.00	36.75
CAM/014/C13J	Special lens hood, bellows type, with holder for 4" x 4" filters - C13 - - - - -	96.00	72 00
CAM/014/C89J	Filter frame for special lens hood - C89 - - - - -	15.00	11 25
CAM/014/C40J	Adapter back, rack-over type with sliding ground glass, for use with roll film holder - C40 - - - - -	122.00	91 50
CAM/014/C92J	Ruled ground glass, only, for C40 back - C92 - - - - -	5.00	3.75
CAM/014/C59J	Adapter back with removable ground glass panel, for use with roll film holder - C59 - - - - -	43.00	32.25
CAM/014/C91J	Reducing adapter back with removable ground glass panel for 2¼" x 3¼" Graflex roll holder - C91 - - - - -	58.00	43.50
CAM/014/C93J	Adapter for Linhof lens board - C93 - - - - -	21.00	15.75
CAM/014/C94J	Adapter for Graphic lens board - C94 - - - - -	21.00	15.75
CAM/014/C81J	Dividing back for 3 exposures on 4" x 5" - C81 - - - - -	135.00	101.25
CAM/014/C03J	Reducing back, 4" x 5" to 2¼" x 3¼" - C3 - - - - -	58.00	43.50
CAM/014/C82J	Dividing back for 3 exposures on 2¼" x 3¼" - C82 - - - - -	123.00	92 25
CAM/014/C04J	Metal bracket for focusing cloth - C4 - - - - -	3.00	2 25
CAM/014/C56J	Spirit level - C56 - - - - -	2.00	1.50
CAM/014/C20K	Carrying Case - C20 - - - - -	62.00	46.50



Prices Subject To Change Without Notice.

BROOKS • BURLEIGH BROOKS INC.

Supercambo Two

BB866 Printed In USA

SUPERCAMBO VIEW CAMERAS - 5" X 7" STANDARD MODEL

<u>CATALOG NO.</u>	<u>DESCRIPTION</u>	<u>SUGGESTED LIST</u>	<u>NET TO DEALER</u>
CAM/014/5X7C3	5" x 7" SUPERCAMBO View Camera, Model III, Complete - - - - - Consists of: Front standard (holds lens board) - C5 Rear standard (holds spring back) - C14 Spring back with ground glass, for double holders - C11 Bellows with mounting flanges - C15 Lens board, 6-7/16 in. square - C7 Square monorail track, 21½ in. long - C16 Tripod mounting head, fixed - C9 Spirit levels, set of 3 - C56/3	\$ 340.00	\$ 255.00
<u>INDIVIDUAL PARTS AND ACCESSORIES FOR 5" X 7" SUPERCAMBO III</u>			
CAM/014/C05J	Front standard (holds lens board) - C5 - - - - -	\$ 117.00	\$ 87.75
CAM/014/C14J	Rear standard (holds spring back) - C14 - - - - -	135.00	101.25
CAM/014/C11J	5" x 7" Spring back with ground glass - C11 - - - - -	54.00	40.50
CAM/014/C44J	Ruled ground glass, only - 5" x 7" - C44 - - - - -	7.00	5.25
CAM/014/C15J	Bellows with mounting flanges - C15 - - - - -	35.00	26.25
CAM/014/C18J	Wide angle bellows - C18 - - - - -	52.00	39.00
CAM/014/C19J	Metal bellows support - (prevents sagging) - C19 - - - - -	15.00	11.25
CAM/014/C07J	Lens board 6-7/16 in. square - C7 - - - - -	4.00	3.00
CAM/014/C42J	Recessed lens board - C42 - - - - -	8.00	6.00
CAM/014/C16J	Square monorail track, 21½ in. long - C16 - - - - -	13.00	9.75
CAM/014/C45J	Additional square monorail - special order - from 4 inches to 40 inches - C45 - per 4 inches - - - - -	4.00	3.00
CAM/014/C09J	Tripod mounting head, fixed - C9 - - - - -	13.00	9.75
CAM/014/C55J	Revolving mounting head, universal joint - C55 - - - - -	35.00	26.25
CAM/014/C95J	Panoram and tilting head - C95 - - - - -	52.00	39.00
CAM/014/C08J	Special lens hood, bellows type - C8 - - - - -	49.00	36.75
CAM/014/C13J	Special lens hood, bellows type, with holder for 4" x 4" filters - C13 - - - - -	96.00	72.00
CAM/014/C89J	Filter frame for special lens hood C89 - - - - -	15.00	11.25
CAM/014/C41J	Adapter back, rack-over type with sliding ground glass, for use with roll film holder - C41 - - - - -	147.00	110.25
CAM/014/C92J	Ruled ground glass, only, for C41 back - C92 - - - - -	5.00	3.75
CAM/014/C49J	Adapter back with removable ground glass panel, for use with roll film holder - C49 - - - - -	70.00	52.50
CAM/014/C47J	Reducing back, 5" x 7" to 4" x 5" - C47 - - - - -	70.00	52.50
CAM/014/C83J	Dividing back for 3 exposures on 4" x 5" - C83 - - - - -	139.00	104.25
CAM/014/C48J	Reducing back 5" x 7" to 2½" x 3½" - C48 - - - - -	70.00	52.50
CAM/014/C84J	Dividing back for 3 exposures on 2½" x 3½" - C84 - - - - -	127.00	95.25
CAM/014/C04J	Metal bracket for focusing cloth - C4 - - - - -	3.00	2.25
CAM/014/C93J	Adapter for Linhof lens board - C93 - - - - -	21.00	15.75
CAM/014/C94J	Adapter for Graphic lens board - C94 - - - - -	21.00	15.75
CAM/014/C56J	Spirit level - C56 - - - - -	2.00	1.50
CAM/014/C21K	Carrying Case - C21 - - - - -	62.00	46.50



Prices Subject To Change Without Notice.

BROOKS • BURLEIGH BROOKS INC.

SUPERCAMBO VIEW CAMERAS 8" X 10" STANDARD MODEL IV

CATALOG NO.	DESCRIPTION	SUGGESTED LIST	NET TO DEALER
CAM/014/810C4A	8" X 10" SUPERCAMBO View Camera, Model IV, Complete - - - - - Consists of: Front standard (holds lens board) - C5 Rear standard (holds spring back) - C35 Spring back with ground glass for double holders - C33 Bellows with mounting flanges - C36 Lens board, 6-7/16 in. square - C7 Square monorail track, 25½ in. long - C37 Sliding rail support for monorail, including double mounting head - C38 Metal bellows support - C19 Spirit levels, set of 3 - C56/3	\$ 749.50	\$ 562.13
<u>INDIVIDUAL PARTS AND ACCESSORIES FOR 8" X 10" SUPERCAMBO IV</u>			
CAM/014/C05J	Front standard (holds lens board) - C5 - - - - -	\$ 117 00	\$ 87.75
CAM/014/C33J	8" x 10" Spring back with ground glass - C33 - - - - -	92 00	69.00
CAM/014/C35JA	Rear standard (holds spring back) swing, tilt, plus horizontal and vertical movements - C35, - - - - -	447 00	335 25
CAM/014/C36J	Bellows with mounting flanges - C36 - - - - -	48.00	36.00
CAM/014/C80J	Wide angle bellows - C80 - - - - -	80.00	63.75
CAM/014/C19J	Metal bellows support - (prevents sagging) - C19 - - - - -	15.00	11.25
CAM/014/C07J	Lens board 6-7/16 in. square - C7 - - - - -	4.00	3 00
CAM/014/C42J	Recessed lens board - C42 - - - - -	8.00	6.00
CAM/014/C37J	Square monorail track, 25½ in. long - C37 - - - - -	19.00	14.25
CAM/014/C45J	Additional square monorail - special order - from 4 inches to 40 inches - C45 - per 4 inches - - - - -	4.00	3.00
CAM/014/C38J	Sliding rail support for monorail w/double mounting head - C38	52.00	39.00
CAM/014/C08J	Special lens hood, bellows type - C8 - - - - -	49.00	36.75
CAM/014/C13J	Special lens hood, bellows type with holder for 4"x 4" filters - C13 - - - - -	96.00	72.00
CAM/014/C89J	Filter frame for special lens hood - C89 - - - - -	15 00	11.25
CAM/014/C51J	Reducing back - 8" x 10" to 5" x 7" - C51 - - - - -	111.00	83.25
CAM/014/C50J	Reducing back - 8" x 10" to 4" x 5" - C50 - - - - -	89.00	66.75
CAM/014/C52J	Reducing back - 8" x 10" to 2½" x 3½" - C52 - - - - -	89.00	66.75
CAM/014/C53J	Adapter back with removable ground glass panel, for use with roll film holder - C53 - - - - -	89.00	66.75
CAM/014/C93J	Adapter for Linhof lens board - C93 - - - - -	21.00	15.75
CAM/014/C94J	Adapter for Graphic lens board - C94 - - - - -	21.00	15.75
CAM/014/C34J	Metal bracket for focusing cloth - C34 - - - - -	5.00	3.75
CAM/014/C54J	Ruled ground glass - 8" x 10" - C54 - - - - -	9.00	6.75
CAM/014/C56J	Spirit level - C56 - - - - -	2.00	1.50
CAM/014/C39J	*Carrying Case - C39 - - - - -	-----	-----
	*in preparation		



Prices Subject To Change Without Notice.

SUPERCAMBO VIEW CAMERAS - 8" X 10" STANDARD MODEL IVB

<u>CATALOG NO.</u>	<u>DESCRIPTION</u>	<u>SUGGESTED LIST</u>	<u>NET TO DEALER</u>
CAM/014/810C4	8" x 10" SUPERCAMBO View Camera, Model IVB, Complete - - - - - Consists of: Front standard (holds lens board) - C5 Rear standard (holds spring back) - C35B Spring back with ground glass for double holders - C33 Bellows with mounting flanges - C36 Lens board, 6-7/16 in. square - C7 Square monorail track, 25½ in. long - C37 Sliding rail support for monorail, including double mounting head - C38 Metal bellows support - C19 Spirit levels, set of 3 - C56/3	\$ 560.00	\$ 420.00
	<u>INDIVIDUAL PARTS AND ACCESSORIES FOR 8" X 10" SUPERCAMBO IVB</u>		
CAM/014/C05J	Front standard (holds lens board) - C5 - - - - -	\$ 117.00	\$ 87.75
CAM/014/C33J	8" x 10" Spring back with ground glass - C33 - - - - -	92.00	69.00
CAM/014/C35J	Rear standard (holds spring back) Swing and tilt, only - C35B	262.00	196.50
CAM/014/C36J	Bellows with mounting flanges - C36 - - - - -	48.00	36.00
CAM/014/C80J	Wide angle bellows - C80 - - - - -	80.00	63.75
CAM/014/C19J	Metal bellows support - (prevents sagging) - C19 - - - - -	15.00	11.25
CAM/014/C07J	Lens board 6-7/16 in. square - C7 - - - - -	4.00	3.00
CAM/014/C42J	Recessed lens board - C42 - - - - -	8.00	6.00
CAM/014/C37J	Square monorail track, 25½ in. long - C37 - - - - -	19.00	14.25
CAM/014/C45J	Additional square monorail - special order - from 4 inches to 40 inches - C45 - per 4 inches - - - - -	4.00	3.00
CAM/014/C38J	Sliding rail support for monorail w/double mounting head - C38 -	52.00	39.00
CAM/014/C08J	Special lens hood, bellows type - C8 - - - - -	49.00	36.75
CAM/014/C13J	Special lens hood, bellows type with holder for 4" x 4" filters - C13 - - - - -	96.00	72.00
CAM/014/C89J	Filter frame for special lens hood - C89 - - - - -	15.00	11.25
CAM/014/C51J	Reducing back - 8" x 10" to 5" x 7" - C51 - - - - -	111.00	83.25
CAM/014/C50J	Reducing back - 8" x 10" to 4" x 5" - C50 - - - - -	89.00	66.75
CAM/014/C52J	Reducing back - 8" x 10" to 2½" x 3½" - C52 - - - - -	89.00	66.75
CAM/014/C53J	Adapter back with removable ground glass panel, for use with roll film holder - C53 - - - - -	89.00	66.75
CAM/014/C93J	Adapter for Linhof lens board - C93 - - - - -	21.00	15.75
CAM/014/C94J	Adapter for Graphic lens board - C94 - - - - -	21.00	15.75
CAM/014/C34J	Metal bracket for focusing cloth - C34 - - - - -	5.00	3.75
CAM/014/C54J	Ruled ground glass - 8" x 10" - C54 - - - - -	9.00	6.75
CAM/014/C56J	Spirit level - C56 - - - - -	2.00	1.50
CAM/014/C39J	*Carrying Case - C39 - - - - -	----	----



*in preparation

Prices Subject To Change Without Notice.

BROOKS • BURLEIGH BROOKS INC.

SUPERCAMBO SPECIAL ACCESSORIES



<u>CATALOG NO.</u>	<u>DESCRIPTION</u>	<u>SUGGESTED LIST</u>	<u>NET TO DEALER</u>
CAM/014/C98J	Lens board to fit rear standard of 5" x 7" Supercambo - C98 -	\$ 6.00	\$ 4.50
CAM/014/C99J	Recessed lens board to fit rear standard of 5" x 7" Supercambo - C99 - - - - -	12.00	9.00
CAM/014/C87J	Blank adapter plate - 8" x 10" - C87 - - - - -	21.00	15.75
CAM/014/C76J	Bellows with mounting flanges - 2½" x 3¼" to 4" x 5" - C76 -	23.00	17.25
CAM/014/C96J	Bellows with mounting flanges - 5" x 7" to 5" x 7" - C96 - -	47.00	35.25
CAM/014/C97J	Bellows with mounting flanges - 8" x 10" to 5" x 7" - C97 - -	53.00	39.75
CAM/014/C90J	Back runner unit - C90 - - - - -	73.00	54.75

CAMBO STANDS AND TRIPODS

CAM/014/ST1S	Cambo Studio Stand Mod. Sst - 1 - - - - -	\$ 595.00	\$ 446.25
CAM/014/ST2S	Cambo Studio Stand Mod. Sst - 2 - - - - -	640.00	480.00
CAM/014/AT1S	Cambo Studio Stand Mod. Ast - 1, with sliding arm - - - - -	889.00	651.75
CAM/014/AT2S	Cambo Studio Stand Mod. Ast - 2, with sliding arm - - - - -	915.00	686.25
CAM/014/LADSC	Cambo Ladder-type Stand, Complete with step and case - - - -	385.00	288.75
CAM/014/LADS	Cambo Ladder-type Stand, only (3 sections) - - - - -	290.00	217.50
CAM/014/STPJ	Step (platform for Cambo Ladder-type Stand) - - - - -	35.00	26.25
CAM/014/LADKC	Canvas Case for Cambo Ladder-type Stand - - - - -	68.00	51.00
CAM/014/RLSJ	Adjustable Rail Support for Cambo Ladder-type Stand - - - - -	98.00	73.50
CAM/014/ODPS	Cambo Model DPS Tripod with geared center post and extension column - - - - -	199.50	149.63
CAM/014/FDSJ	Cover for DPS Tripod - - - - -	32.00	24.00
CAM/014/OOAS	Cambo Model A Tripod - - - - -	115.00	86.25
CAM/014/OOBS	Cambo Model B Tripod - - - - -	155.00	116.25
CAM/014/OOCS	Cambo Model C Tripod - - - - -	330.00	247.50
CAM/014/DSWS	Cambo Tripod Dolly - - - - -	85.00	63.75
CAM/014/CBHJ	Cambo Jumbo Ball and Socket Tripod Top - - - - -	9.95	5.97

Prices Subject To Change Without Notice.

The following items are NEW and have not been previously listed in our Super Cambo Price List.

<u>Catalog No.</u>	<u>Description</u>	<u>List</u>	<u>Net</u>
<u>NEW CAMBO CAMERAS WITH DOUBLE LOCKS</u>			
CAM/014/2x3C1D	2½x3¼ Camera Complete - - - - -	295.00	221.25
CAM/014/4x5C2D	4x5 Camera Complete - - - - -	320.00	240.00
CAM/014/5x7C3D	5x7 Camera Complete - - - - -	365.00	273.75
CAM/014/8x10C4D	8x10 Model IV Camera Complete - - - -	762.00	571.50
CAM/014/8x10C4BD	8x10 Model IVB Camera Complete - - -	572.50	429.38

NEW CAMBO ACCESSORIES

CAM/014/C100J	Swing-up Bellows Lenshood with filter holder, for 4x5, 5x7 and 8x10 - - - -	118.00	88.50
CAM/014/C85J	Upright extenders for C-5 Standards -	6.00	4.50

NEW CAMBO CARRYING CASES

CAM/014/C20A	Fibre Case for 2½x3¼, 4x5 or 5x7 Camera - - - - -	45.00	33.75
CAM/014/C20B	Fibre Case for 2½x3¼ or 4x5 Camera -	45.00	33.75
CAM/014/C70	Metal Case for 2½x3¼ Camera - - - - -	100.00	75.00
CAM/014/C20	Metal Case for 4x5 Camera - - - - -	105.00	78.75
CAM/014/C21	Metal Case for 5x7 Camera - - - - -	115.00	86.25
CAM/014/C39	Metal Case for 8x10 Camera - - - - -	215.00	161.25

NEW CAMBO STUDIO CAMERA STANDS

CAM/014/BST	Compact Model - - - - -	350.00	262.50
-------------	-------------------------	--------	--------

Prices Subject To Change Without Notice.